

HINTS & SOLUTIONS

EXERCISE - 1

Single Choice

1. $V_0(C + CV) = CV + (2C)(2V)$
 $V_0 = V$ (Final pot. diff.)

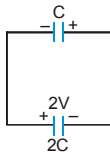

$$\therefore U_{\text{final}} = \frac{1}{2}(C + 2C)V_0 = \frac{3CV^2}{2}$$

2. $P = \frac{\Delta U}{\Delta t} = \frac{\frac{1}{2}CV^2}{\Delta t} = \frac{\frac{1}{2} \times 40 \times 10^{-6} \times 9 \times 10^6}{2 \times 10^{-3}} = 90 \text{ kW}$

3. $k = \frac{f}{x} = \frac{5000}{0.2} = 2,5000 \text{ N/m}$

$$\frac{U_{\text{SPR}}}{U_{\text{CAP}}} = \frac{\frac{1}{2}kx^2}{\frac{1}{2}CV^2} = \frac{25000 \times 0.2 \times 0.2}{10 \times 10^{-6} \times 10^8} = 1$$

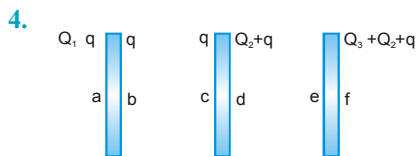

Here $Q_1 - q = Q_2 + Q_3 + q \Rightarrow q = \frac{Q_1 - (Q_2 + Q_3)}{2}$

Charge on a = Charge on f

$$\Rightarrow Q_1 - q = \frac{\Sigma Q}{2} = \frac{Q_1 + Q_2 + Q_3}{2}$$

5. $C = \frac{\epsilon_0 A}{d - t + \frac{t}{K}} \left(t = \frac{d}{2}, K = \infty \right)$
 $= \frac{\epsilon_0 A}{d - \frac{d}{2} + \frac{d}{2K}} = \frac{2 \epsilon_0 A}{d} = 2C_0$

6. Before sharing $U_i = \frac{Q_1^2}{2C_1} + \frac{Q_2^2}{2C_2}$
 After sharing $U_f = \frac{(Q_1 + Q_2)^2}{2(C_1 + C_2)}$

$$\Delta U = U_f - U_i = \frac{(Q_1 + Q_2)^2}{2(C_1 + C_2)} - \frac{Q_1^2}{2C_1} + \frac{Q_2^2}{2C_2}$$

$$= - \frac{(Q_1 C_2 - Q_2 C_1)^2}{2C_1 C_2 (C_1 + C_2)}$$

-ve sign indicates there is decrease in energy

But $Q_1 C_2 - Q_2 C_1 \neq 0 \Rightarrow Q_1 C_2 \neq Q_2 C_1$

$\Rightarrow Q_1 4\pi\epsilon_0 R_2 \neq Q_2 4\pi\epsilon_0 R_1 \Rightarrow Q_1 R_2 \neq Q_2 R_1$

7. $(4+2)V = (4 \times 50) + (2 \times 100)$

$$V = \frac{400}{6} = \frac{200}{3} \text{ V}$$

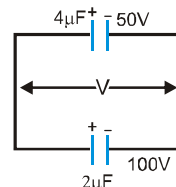

$$U_{\text{initial}} = \left(\frac{1}{2} \times 4 \times (50)^2 + \frac{1}{2} \times 2 \times (100)^2 \right) \times 10^{-6}$$

$$= (5000 + 10000) \times 10^{-6} = 1.5 \times 10^{-2} \text{ J}$$

$$U_{\text{final}} = \frac{1}{2}(4 + 2) \times 10^{-6} \times \frac{200}{3} \times \frac{200}{3}$$

$$= 1.33 \times 10^{-2} \text{ J}$$

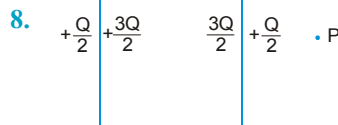

$$\text{Force on either plate} = \frac{(3Q/2)^2}{2A \epsilon_0} = \frac{9Q^2}{8A \epsilon_0}$$

Force on point 'P' due to capacitor = 0

$$\text{Potential diff. between the plates} = \frac{3Q}{2C}$$

Energy stored in electric field between the plates

$$= \frac{1}{2}C \times \left(\frac{3Q}{2C} \right)^2 = \frac{9Q^2}{8C}$$

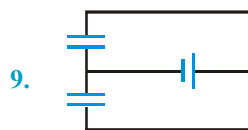

$$U = \frac{1}{2}C_1 V^2 + \frac{1}{2}C_2 V^2 = \frac{1}{2}(C_1 + C_2)V^2$$

$$= \frac{1}{2} \left(\frac{8.85 \times 10^{-12} \times 0.1}{0.885 \times 10^{-3}} \times 2 \right) \times 10^2 = 10^{-1} \mu\text{J}$$

10.

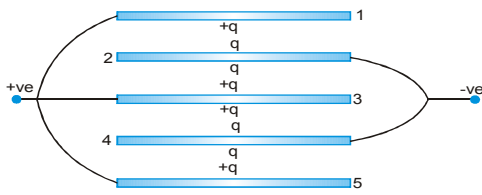

Therefore

$$q_2 = -2q, q_3 = +2q,$$

$$q_4 = -2q \text{ and } q_5 = +q$$

11.

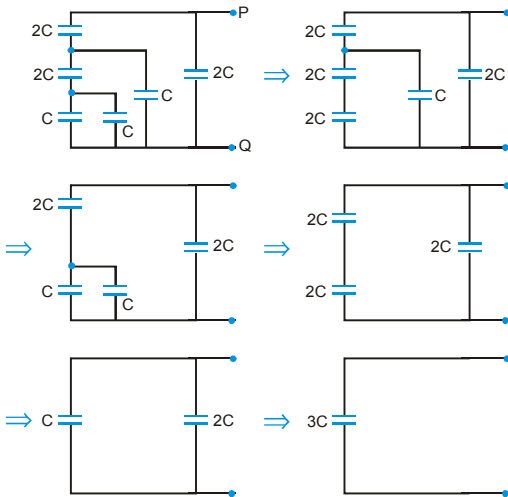

12. Each capacitor has potential difference 'V' and energy

$$\frac{1}{2}CV^2. \text{ After reconnecting total energy remains}$$

constant and total voltage becomes NV.

13. For 'n' plates; effective C will be (n-1)C.

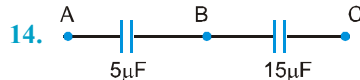

$$5(V_A - V_B) = 15(V_B - V_C)$$

$$\Rightarrow 5(2000 - V_B) = 15(V_B - 0)$$

$$\Rightarrow 2000 - V_B = 3V_B$$

$$\Rightarrow V_B = 500V$$

15. $C_{\text{eff}} = C + \frac{C}{2} + \frac{C}{4} + \frac{C}{8} + \frac{C}{16} + \dots$

$$= \frac{C}{1 - 1/2} = 2C = 2\mu\text{F}$$

16. $C = \frac{\epsilon_0 A}{d} = 9\text{pF}$

$$C' = \frac{\epsilon_0 A}{d - t_1 + \frac{t_1}{K_2} - t_2 + \frac{t_2}{K_2}} = \frac{\epsilon_0 A}{d - \frac{d}{3} + \frac{d}{9} - \frac{2d}{3} + \frac{d}{9}}$$

$$= \frac{9}{2} \frac{\epsilon_0 A}{d} = \frac{81}{2} \text{pF} = 40.5\text{pF}$$

17. $CV + 2CV = KCV' + 2CV' \Rightarrow V' = \frac{3V}{K+2}$

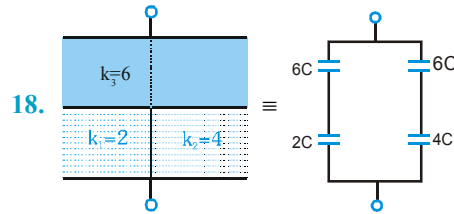

where $C = \frac{\epsilon_0 A}{d}$

$$C_{\text{eq}} = \frac{6C \times 2C}{8C} + \frac{6C \times 4C}{10C} = 3.9C$$

19. $\frac{1}{2} CV^2 = ms\Delta T \Rightarrow V = \sqrt{\frac{2ms\Delta T}{C}}$

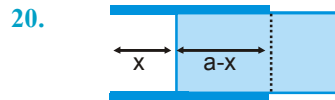

$$C = \frac{\epsilon_0 ax}{d} + \frac{K \epsilon_0 (a-x)a}{d}$$

$$C = \frac{K \epsilon_0 a^2}{d} - \frac{\epsilon_0 a(K-1)}{d} x \text{ where } x = vt$$

∴ C-t graph is linear with negative slope.

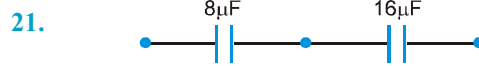

Breaking voltage 20 V 80 V

Safe Voltage 20 V 10 V

∴ Charge on each capacitor = 20 × 8 = 160 μC

22. $C = 4\pi \epsilon_0 a$

$$C' = \frac{4\pi \epsilon_0 ab}{b-a} = \frac{4\pi \epsilon_0 a}{1 - \frac{a}{b}} = \frac{4\pi \epsilon_0 a}{1 - \left(\frac{n-1}{n}\right)} = n(4\pi \epsilon_0 a)C$$

23. Capacitance between 1 and 3 and between 2 and 4 are symmetrical.

24. 
 Breaking voltage 6 kV 4 kV
 Safe Voltage 6 kV 3 kV
 ∴ Total voltage = 9 kV

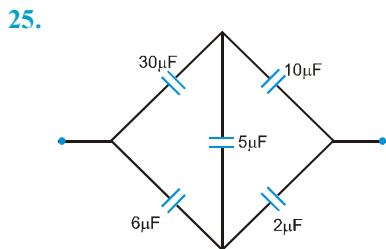

The system is a balanced Wheatstone bridge.

$$\therefore C_{\text{eff}} = \left(\frac{10 \times 30}{10 + 30} + \frac{6 \times 2}{6 + 2} \right) = 9 \mu\text{F}$$

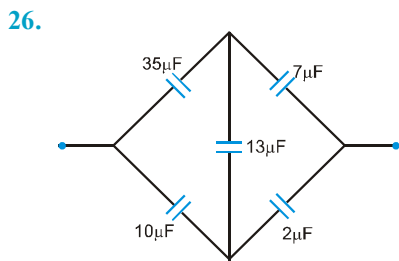

The system is a balanced Wheatstone bridge.

$$\therefore C_{\text{eff}} = \left(\frac{35 \times 7}{35 + 7} + \frac{10 \times 2}{10 + 2} \right) = \frac{15}{2} \mu\text{F}$$

27. There is no closed path for flow of current. Hence no current flows. Hence heat developed is zero.

28. $VA = 3 \left(\frac{q}{C} \right) = 3 \times 2.5 = 7.5 \text{ volt}$

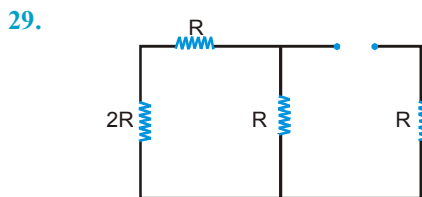

To find the time constant of a RC circuit, Short circuit the battery

$$R_{\text{eff}} = \frac{7R}{4} \quad \therefore \tau = \frac{7RC}{4}$$

EXERCISE - 2

Part # I : Multiple Choice

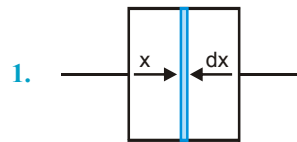

$$\int \frac{1}{dC} = \int \frac{dy}{K \epsilon_0 A} = \int_0^d \frac{dy}{\lambda \epsilon_0 A \sec\left(\frac{\pi y}{2d}\right)}$$

$$\Rightarrow C = \frac{\lambda \epsilon_0 A \pi}{2d}$$

2. Both A and B are always in parallel.

3. $E = \frac{V_0}{d} \Rightarrow E_F < E_D$ Also $\sigma_A > \sigma_B$

4. $q = q_0 e^{-t/\tau} \therefore i = \frac{dq}{dt} = \frac{q_0}{\tau} e^{-t/\tau} = i_0 e^{-t/\tau}$

$$\therefore q_0 = i_0 \tau$$

Initial stored energy = $\frac{1}{2} CV^2 = \frac{1}{2} (CV)V$

$$= \frac{1}{2} (i_0 \tau) (i_0 R) = \frac{1}{2} i_0^2 R \tau$$

5. $V = V_0 e^{-t/RC}$

$$\left| \frac{dV}{dt} \right| = \frac{V_0}{RC} e^{-t/RC} = \text{slope} (< \text{ky})$$

At $t = 0$, for $R = R_A$; slope is least in curve-3.

6. $q = q_0 e^{-t/\tau}$

$$\Rightarrow i = \frac{dq}{dt} = \frac{q_0}{\tau} e^{-t/\tau} = \frac{CV_0}{RC} e^{-t/\tau} = \frac{V_0}{R} e^{-t/\tau}$$

At $t=0$; $i_1 = \frac{V_0}{R_1}$; $i_2 = \frac{V_0}{R_2}$

$$\therefore R_1 = R_2 \quad \therefore i_1 = i_2$$

As τ is less for C_1 and hence it loses charges faster than C_2 .

7. As B is in parallel with C and the potential develops slowly. Hence during charging more heat is produced in A than in B. In steady state, same current passes through A and B.

$$\therefore V_{\text{capacitor}} = \frac{E}{2} \quad \therefore E_{\text{capacitor}} = \frac{1}{2} C \left(\frac{E}{2} \right)^2 = \frac{CE^2}{8}$$

8.

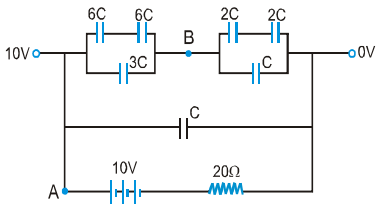

$$(V_A - V_B) 6C = (V_B - 0) 2C \Rightarrow V_B = 7.5 \text{ V}$$

$$\therefore V_A - V_B = 10 - 7.5 = 2.5 \text{ V}$$

9.

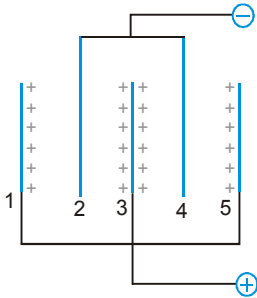

$$\text{Charge on plate } \neq 1 = \frac{\epsilon_0 AV}{d}$$

$$\text{Charge on plate } \neq 4 = -\frac{2 \epsilon_0 AV}{d}$$

10. $C_{\text{eff}} = 1/4 \mu\text{F}$

$$\therefore \text{Total no. of rows of capacitor} = \frac{C_{\text{net}}}{C_{\text{eff}}} = \frac{3}{1/4} = 12$$

$$\therefore \text{Total no. of capacitors needed} = 12 \times 4 = 48$$

11. Force on plate

$$= \frac{\sigma^2 A}{2 \epsilon_0} = \frac{Q^2}{2A \epsilon_0} = Kx = mg$$

$$\therefore Q = \sqrt{2mgA \epsilon_0}$$

12. $i = 10e^{-t/RC} \Rightarrow 2.5 = 10 e^{-2/RC}$

$$\Rightarrow RC = \tau = \frac{1}{\ln 2} \quad \& \quad C = \frac{1}{10 \ln 2}$$

For capacitor

$$\frac{V_0}{R} = 10 \Rightarrow V_0 = 10R = 100 \text{ volt}$$

Total heat developed = Total initial energy stored in

$$\text{capacitor. } \frac{1}{2} CV^2 = \frac{500}{\ln 2}$$

$$\text{Thermal power in resistor } P = i^2 R = 100 R e^{-2t/RC}$$

$$\therefore \text{Time-constant} = \frac{RC}{2} = \frac{1}{2 \ln 2}$$

13. $C_{\text{eff}} = C_{\text{EF}} = \frac{\epsilon_0 A}{d} \quad \therefore E_{\text{net}} = \frac{1}{2} CV^2 = \frac{\epsilon_0 AV^2}{2d}$

14. Time constant

$$= CR_{\text{eff}} = (100 \times 10^{-6}) \left(\frac{10^3}{2} \right) \text{ s} = 50 \text{ m/s}$$

15.

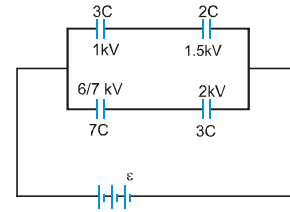

Safe voltages in each arm are mentioned.

$$\therefore (1+1.5) < (6/7+2) \quad \therefore E_{\text{safe}} = 1+1.5 = 2.5 \text{ kV}$$

16.

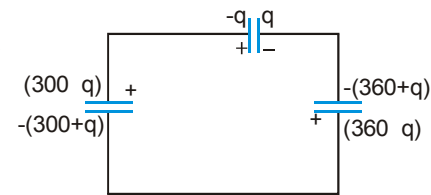

$$\Rightarrow \frac{300-q}{2} - \frac{q}{1.5} + \frac{360-q}{3} = 0 \Rightarrow q = 180$$

$$\therefore q_{1.5\mu\text{F}} = 180 \mu\text{C}, q_{3\mu\text{F}} = 540 \mu\text{C}, q_{2\mu\text{F}} = 480 \mu\text{C}$$

17. $i_1 = \frac{V}{R} e^{-t/RC_1}, i_2 = \frac{V}{R} e^{-t/RC_2}$

$$\therefore \frac{i_1}{i_2} = e^{t/R \left(\frac{1}{C_2} - \frac{1}{C_1} \right)} = e^{+\frac{t}{2RC_2}}$$

$\Rightarrow i_1/i_2$ increases with time, t.

18. At $t=0, VC=0 \Rightarrow i_{R_3} = 0$

$$Q_{\text{max}} = C \left[\frac{\epsilon}{\frac{R_1 R_2}{R_1 + R_2} + R_3} \right] = \frac{10C}{1+1} = 5 \times 1 = 5 \mu\text{C}$$

$$\therefore (I_{R_3})_{\max} = \frac{V_C}{R_3} = \frac{5}{1} = 5A$$

Since R_1 and R_2 are in parallel hence current ratio of R_1 and R_2 will remain same.

19. $i = \frac{i_0}{2} = i_0 e^{-t/RC} \Rightarrow \frac{1}{2} = e^{-\ln 4 / RC}$

$$\Rightarrow RC=2 \Rightarrow (2+t) \frac{1}{2} = 2 \Rightarrow t = 2\Omega$$

18. At $t=0$, $V_C = 0 \Rightarrow i_{R_3} = 0$

$$Q_{\max} = C \left[\frac{\epsilon}{\frac{R_1 R_2}{R_1 + R_2} + R_3} \right] = \frac{10C}{1+1} = 5 \times 1 = 5\mu C$$

$$\therefore (I_{R_3})_{\max} = \frac{V_C}{R_3} = \frac{5}{1} = 5A$$

Since R_1 and R_2 are in parallel hence current ratio of R_1 and R_2 will remain same.

20. $q = q_0 e^{-t/RC} \Rightarrow I = \frac{q_0}{RC} e^{-t/RC}$

$$\Rightarrow \ln I = \ln \left(\frac{q_0}{RC} \right) - \frac{t}{RC} = \ln \left(\frac{V_0}{R} \right) - \frac{t}{RC}$$

As I_{\max} does not change $\therefore R = \text{constant}$

$$\left| \frac{d(\ln I)}{dt} \right| = \left| 0 - \frac{1}{RC} \right| \Rightarrow \left[\frac{d(\ln I)}{dt} \right]_1 > \left[\frac{d(\ln I)}{dt} \right]_2$$

$\therefore C_2 > C_1 \Rightarrow C$ is increased

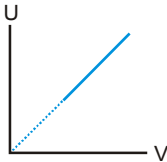
21. $C = \frac{\epsilon_0 ax}{d} + \frac{K \epsilon_0 (a-x)a}{d}$ 

$$= \frac{K \epsilon_0 a^2}{d} - \frac{\epsilon_0 a(K-1)vt}{d}$$

$$V = \frac{Q}{C} \text{ and } U = \frac{QV}{2} \quad \therefore \frac{U}{V} = \frac{Q}{2}$$

22.

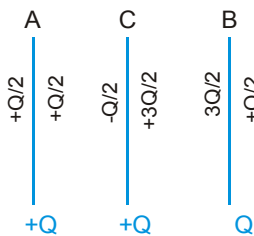

$$\text{Initial } V'_{AB} = \frac{Q}{C} = \frac{Qd}{\epsilon_0 A}$$

$$\text{Final } V_{AB} = \frac{Q/2}{\left(\frac{2\epsilon_0 A}{d}\right)} + \frac{(3Q/2)}{\left(\frac{2\epsilon_0 A}{d}\right)} = \frac{Qd}{\epsilon_0 A} = V_{AB}$$

23.

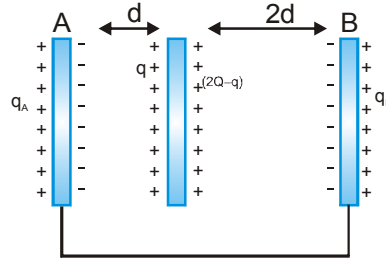

$$\Delta V = \frac{qd}{\epsilon_0 A} = \frac{(2Q-q)(2d)}{\epsilon_0 A} \Rightarrow q = \frac{4Q}{3}$$

Total charge on inner faces of A and B = $-2Q$

Rest charge will equally appear on their outer faces

$$= \frac{Q - (-2Q)}{2} = \frac{3Q}{2}$$

$$\text{Final charge on plate A} = \frac{3Q}{2} - \frac{4Q}{3} = \frac{Q}{6}$$

$$\therefore \text{Charge flown through wire} = Q - \frac{Q}{6} = \frac{5Q}{6}$$

24.

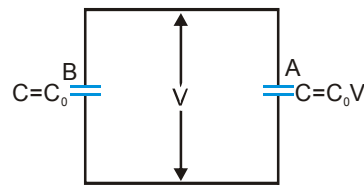

$$(C_0 + C_0 V) V = 30 C_0$$

$$\Rightarrow V^2 + V - 30 = 0 \Rightarrow V = 5 \text{ volt}$$

$$\therefore V_A = V_B = 5 \text{ volt}$$

$$Q_A = 52C_0 = 25C_0; Q_B = 5C_0$$

25.

$$C_{\text{eq}} = \frac{KC}{K+1}, C'_{\text{eq}} = \frac{C}{2}$$

$$\Rightarrow \frac{Q'_2}{Q_2} = \frac{K+1}{2K}$$

26. Final charge distribution

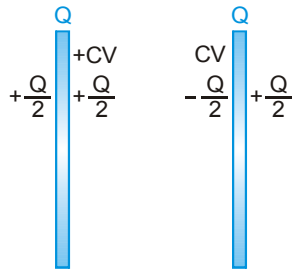

Therefore potential difference across the capacitor

$$= \frac{CV + \frac{Q}{2}}{C} = V + \frac{Q}{2C}$$

27. $Q = \frac{C}{2}E$

$$Q' = \frac{KCC}{KC + C}E = \frac{KC}{K + 1}E$$

$$\therefore Q' - Q = \frac{KCE}{K + 1} - \frac{CE}{2} = \frac{(K - 1)CE}{2(K + 1)}$$

This charge is supplied by battery.

28. At $t = 0$, $V_{\text{capacitors}} = 0$

$$\Rightarrow I_2 = I_3 = 0 \text{ and } I_1 = \frac{6}{2} = 3A$$

$$\text{At } t \rightarrow \infty, I_1 = I_3 = \frac{6}{2 + 8} = 0.6A, I_2 = 0$$

29. At $t = \infty$, capacitor gets open circuited

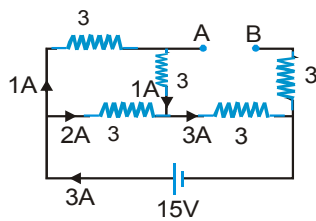

$$\therefore I = \frac{15}{5} = 3A \Rightarrow V_A - 3 \times 1 - 3 \times 3 = V_B$$

$$\Rightarrow V_A - V_B = 12V$$

30. In steady state

$$I_{\text{upper arm}} = I_{\text{lower arm}} = \frac{120}{6} = 20A$$

$$\text{For the right most loop } 3I - 3I + \frac{q}{C_2} = 0 \Rightarrow q = 0$$

For the left most loop

$$20 \times 1 + \frac{q}{C_1} - 20 \times 2 = 0$$

$$\Rightarrow q = (40 - 20)C_1 = 20C_1 = 40 \mu C$$

31. $\epsilon = \frac{Q_0}{C_1} \therefore Q_1 = Q_0; Q_2 = \left(\frac{Q_0}{C_1}\right)C_2$

$$V_1 = V_2 = \epsilon = \frac{Q_0}{C_1}; U_1 = \frac{1}{2}C_1 \left(\frac{Q_0}{C_1}\right)^2 = \frac{Q_0^2}{2C_1}$$

$$U_2 = \frac{1}{2}C_2 \left(\frac{Q_0}{C_1}\right)^2 = \frac{Q_0^2 C_2}{2C_1^2}$$

32. Energy = $\frac{Q^2}{2C} = \frac{Q^2 d}{2 \epsilon_0 A}$

As d decreases, E decreases

33. Charge on $3 \mu F$ capacitor

$$= 6 \times 7 = 42 \mu C$$

$$\therefore V_{3 \mu F} = \frac{42}{3} = 14 \text{ volt}$$

$$\therefore V_{3.9 \mu F} = 14 + 6 = 20 \text{ volt}$$

$$\text{Charge on } 3.9 \mu F \text{ capacitor} = 20 \times 3.9 = 78 \mu C$$

$$\therefore \text{Total charge} = 78 + 42 = 120 \mu C$$

$$\therefore V_{12 \mu F} = \frac{120}{12} = 10V$$

$$\therefore \epsilon = 20 + 10 = 30V$$

34. $Q = CV = \frac{\epsilon_0 AV}{d}$

$$E = \frac{V'}{d} = \frac{V/K}{d} = \frac{V}{Kd}$$

$$W = \frac{1}{2}Q^2 \left(\frac{1}{C} - \frac{1}{C'}\right) = \frac{CV^2}{2} \left(1 - \frac{1}{K}\right)$$

35. $U_{\text{initial}} = \frac{1}{2}CV^2; U_{\text{final}} = \frac{1}{2}CV^2 \therefore \Delta U = 0$

$$\therefore \text{Heat} = \text{work done by battery} = [CV - (-CV)]V = 2CV^2$$

36. S-open ; $V_{\text{inner}} = V_{\text{outer}}$

S-closed ; $V_{\text{inner}} = 0$

$$\Rightarrow \frac{KQ}{3R} + \frac{Kq}{R} = 0 \Rightarrow q = -Q/3$$

$$C_{\text{initial}} = 4\pi \epsilon_0 (3R)$$

$$C_{\text{final}} = 4\pi \epsilon_0 (3R) + \frac{4\pi \epsilon_0 (3R)(R)}{(3R - R)}$$

$$\therefore C_{\text{final}} > C_{\text{initial}}$$

37. $W_{\text{ext}} = -\Delta U = U_i - U_f$

$$= \frac{1}{2} \times 2\mu\text{F} \times 400 - \frac{1}{2} \times 1\mu\text{F} \times 400 = 200\mu\text{J}$$

38. V decreases continuously from left to right except in conductor where it is constant.

39. $eV = \frac{1}{2} m (v_2^2 - v_1^2)$

$$\Rightarrow 1.6 \times 10^{-19} \times 20 = \frac{1}{2} \times 9.11 \times 10^{-31} \times (v^2 - 0)$$

$$\Rightarrow v = 2.65 \times 10^6 \text{ m/s}$$

40. $\Delta Q = 2CV - (-CV) = 3CV$

$$WB = \Delta Q(2V) = 6CV^2$$

$$\Delta U = U_f - U_i = \frac{1}{2} C(2V)^2 - \frac{1}{2} CV^2 = \frac{3CV^2}{2}$$

$$\therefore \text{Heat} = W_B - \Delta U = \frac{9CV^2}{2}$$

$$U_f = \frac{1}{2} C(2V)^2 = 2CV^2$$

$$\therefore \frac{\text{Heat}}{U_f} = \frac{9}{4} = 2.25$$

41.

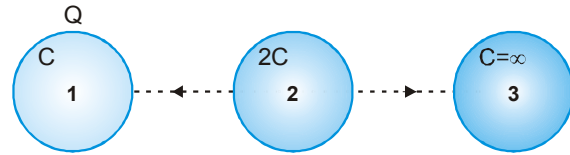

Initial charge on 1 = Q when C_1 & C_2 touches

$$\Rightarrow \frac{Q_1}{Q_2} = \frac{C}{2C} = \frac{1}{2} \Rightarrow Q_1 = \frac{Q}{3}, Q_2 = \frac{2Q}{3}$$

Now when Q_2 & Q_3 is touched

$$\Rightarrow \frac{Q_2}{Q_3} = \frac{C_2}{C_3} = \frac{2C}{\infty} = 0 \Rightarrow Q_2 = 0$$

Again when Q_1 & Q_2 is touched

$$Q_2 = 2 \frac{(Q/3)}{3} \Rightarrow Q_1 = \frac{(Q/3)}{3} = \frac{Q}{9}$$

Similarly we can say after N times it becomes

$$Q_1 = \frac{Q}{3^N}$$

42.

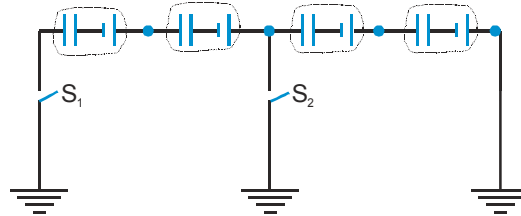

Potential difference across each capacitor and cell combination is zero.

Part # II : Assertion & Reason

- | | | | | | |
|----|-----|----|-----|----|-----|
| 1. | (D) | 2. | (C) | 3. | (A) |
| 4. | (A) | 5. | (B) | 6. | (B) |

EXERCISE - 3

Part # I : Matrix Match Type

1.

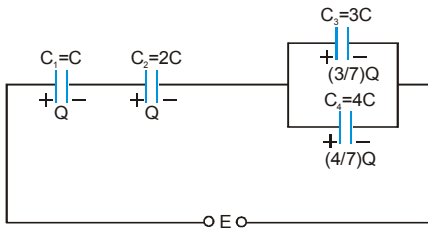

$$\text{At } C_1 = V_1 = \frac{Q}{C} \quad \text{and} \quad U_1 = \frac{Q^2}{2C}$$

$$\text{At } C_2 = V_2 = \frac{Q}{2C} \quad \text{and} \quad U_2 = \frac{Q^2}{4C}$$

$$\text{At } C_3 = V_3 = \frac{Q}{7C} \quad \text{and} \quad U_3 = \frac{3Q^2}{98C}$$

$$\text{At } C_4 = V_4 = \frac{Q}{7C} \quad \text{and} \quad U_4 = \frac{4Q^2}{98C}$$

Therefore $V_{\max} = V_1$ and $V_{\min} = V_3 = V_4$
and $U_{\max} = U_1$ and $U_{\min} = U_3$

2. Initial charge $q_1 = \frac{CE}{2}$

Final charge $q_2 = CE$

Initial stored energy

$$U_1 = \frac{1}{2} C(E/2)^2 + \frac{1}{2} C(E/2)^2 = \frac{CE^2}{4}$$

$$\text{Final stored energy } U_2 = \frac{CE^2}{2}$$

Charge supplied by battery

$$\Delta Q = q_2 - q_1 = CE - \frac{CE}{2} = \frac{CE}{2}$$

$$\text{Work done by battery } W_B = \Delta QE = \frac{CE^2}{2}$$

Heat developed in the system

$$H = W_B - \Delta U = \frac{CE^2}{2} - \left(\frac{CE^2}{2} - \frac{CE^2}{4} \right) = \frac{CE^2}{4}$$

Part # II : Comprehension

Comprehension-1

1. Time Constant

$$\tau = R_1 C = 8 \times 6 = 48 \mu\text{s}$$

$$2. \quad V_t = 2\tau = V_0(1 - e^{-t/\tau}) = 12(1 - e^{-2t/\tau})$$

$$= 12 \left(1 - \frac{1}{7.4} \right) = 10.4 \text{ V}$$

$$3. \quad (V_{R_1})_t = 2\tau = V_0 - V_{\text{capacitor}} = 12 - 10.4 = 1.6 \text{ V}$$

$$4. \quad V_{R_2} = V_0 = 12 \text{ V}$$

Comprehension -2

1. In steady state

$$I_{\text{circuit}} = \frac{V}{R_1 + R_2} = \frac{18}{3 + 6} = 2 \text{ A}$$

$$V_{R_2} = V_{C_2} = IR_2 = 2 \times 6 = 12 \text{ V}$$

$$Q_{C_2} = C_2 V_{C_2} = 12 \times 4 = 48 \mu\text{C}$$

$$2. \quad Q_{\text{initial}} = Q_{C_1} + Q_{C_2} = IR_1 C_1 + IR_2 C_2$$

$$= 3 \times 2 \times 2 + 3 \times 4 \times 4 = 12 + 48 = 60 \mu\text{C}$$

$$Q_{\text{final}} = V(C_1 + C_2) = 18(2+4) = 108 \mu\text{C}$$

$$\therefore \Delta Q = 108 - 60 = 48 \mu\text{C (through } S_1)$$

$$3. \quad U_{\text{initial}} = \frac{1}{2} C_1 V_1^2 + \frac{1}{2} C_2 V_2^2$$

$$= \frac{1}{2} \times 2 \times 6^2 + \frac{1}{2} \times 4 \times 12^2 = 324 \mu\text{J}$$

$$U_{\text{final}} = \frac{1}{2} (C_1 + C_2) V^2 = \frac{1}{2} (2+4) 18^2 = 972 \mu\text{J}$$

$$\Delta Q = Q_f - Q_i = 48 \mu\text{C}$$

$$W_{\text{Battery}} = \Delta Q \cdot V = 48 \times 18 = 864 \mu\text{J}$$

$$\therefore \text{Heat} = W_B - \Delta U = 864 - (972 - 324) = 216 \mu\text{J}$$

Comprehension-3

1. $q_{1\max} = q_{2\max}$

C_1 and C_2 may be different and hence E_1 and E_2 may be different.

$$2. \quad \tau_2 > \tau_1 \Rightarrow R_2 C_2 > R_1 C_1 \Rightarrow \frac{R_1}{R_2} < \frac{C_2}{C_1}$$

Comprehension-4

- $\frac{C_A}{C_B} = \frac{\epsilon_0 A/d}{K \epsilon_0 A/d} = 1 : K$
- $\frac{V_A}{V_B} = \frac{Q/C_A}{Q/C_B} = \frac{C_B}{C_A} = K : 1$
- $(V_A)_{\text{initial}} = \frac{V}{2}; (V_A)_{\text{final}} = \frac{E(KC)}{C(K+1)} = \frac{KE}{K+1}$
 $\therefore \frac{(V_A)_{\text{initial}}}{(V_A)_{\text{final}}} = \frac{K+1}{2K}$
- $(V_B)_{\text{initial}} = \frac{V}{2}; (V_B)_{\text{final}} = \frac{Q}{C_B} = \frac{E(KC)}{(K+1)KC} \times \frac{1}{KC} = \frac{E}{K+1}$
 $\therefore \frac{(V_B)_{\text{initial}}}{(V_B)_{\text{final}}} = (K+1) : 2$
- $(U_A)_{\text{final}} = \frac{Q^2}{2C_A}; (U_B)_{\text{final}} = \frac{Q^2}{2C_B}$
 $\therefore \left(\frac{U_A}{U_B} \right)_{\text{Final}} = K : 1$

Comprehension-5

- $V_b = \epsilon_0 (1 - e^{-t/RC})$
 $\Rightarrow 110 = 120 (1 - e^{-t/RC})$
 $\Rightarrow e^{-t/RC} = 1/12$
 $\Rightarrow t/RC = \ln 12 = 2.5$
 $\Rightarrow t = RC \times 2.5 = 10^6 \times 10^{-6} \times 2.5 = 5/2 \text{ sec}$
- $\tau_0 = 10^{-6} \times 10 = 10 \mu\text{s}$
- Flash duration = $3\tau_0 = 30 \mu\text{s}$
- Energy in flash
 $= \frac{1}{2} CV^2 = \frac{1}{2} \times 1 \times 10^{-6} \times 110 \times 110 = 6.1 \text{ mJ}$

EXERCISE - 4

Subjective Type

- Equivalent capacity between A and B

$$C = \frac{9}{3} + 3 = 6 \mu\text{F}$$

- Stored charge

$$Q = CV = 6 \times 10^{-6} \times 4 = 24 \mu\text{C}$$

- Stored energy

$$U = \frac{1}{2} CV^2 = \frac{1}{2} \times 6 \times 10^{-6} \times 16 = 48 \mu\text{J}$$

- $CV = \frac{qt}{t} \Rightarrow 400 \times 10^{-6} \times 100 = 100 t$
 $\Rightarrow t = 400 \text{ s}$

- Electric field

$$E = \frac{V_A - V_B}{d} = \frac{(10,000 - 0)}{(2 \times 10^{-3})} = 5 \times 10^6 \text{ V/m}$$

- Common potential

$$V_{\text{cm}} = \frac{C_1 V_1 + C_2 V_2}{C_1 + C_2} = \frac{2 \times 200 + 3 \times 400}{2 + 3} = 320 \text{V}$$

$$\text{Charge on } C_1 Q_1 = C_1 V_{\text{cm}} = 2 \times 320 \mu\text{C} = 640 \mu\text{C}$$

$$\text{Charge on } C_2 Q_2 = C_2 V_{\text{cm}} = 3 \times 320 \mu\text{C} = 960 \mu\text{C}$$

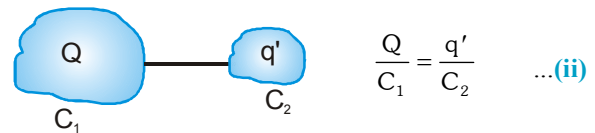
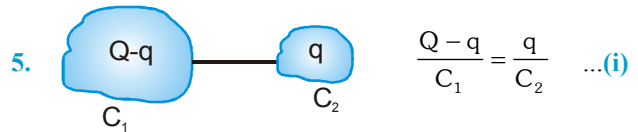

$$\text{Eq. (i)} \div \text{(ii)} : q' = \frac{Qq}{Q-q}$$

- By using KCL

$$C_1 (V_A - V_0) + C_2 (V_B - V_0) + C_3 (V_C - V_0) = 0$$

$$\Rightarrow V_0 = \frac{C_1 V_A + C_2 V_B + C_3 V_C}{C_1 + C_2 + C_3}$$

- $\therefore C = \frac{\epsilon_0 A}{d}; q = \left(\frac{\epsilon_0 A}{d} \right) V$

$$\text{Slope} = \frac{\epsilon_0 A}{d} \quad \therefore C_2 > C_1 > C_3$$

8. (i) On connecting with the second capacitor the charge distributes equally

$$\therefore V_{CM} = \frac{C_1 V_1 + C_2 V_2}{C_1 + C_2} = \frac{0.1 \times 10}{0.1 + 0.1} = 5V$$

Total stored energy

$$U_f = \frac{1}{2} C_1 V_{CM}^2 + \frac{1}{2} C_2 V_{CM}^2$$

$$= \frac{1}{2} \times 0.1 \times 10^{-6} \times (5)^2 + \frac{1}{2} \times 0.1 \times 10^{-6} \times (5)^2$$

$$= 2.5 \mu J$$

- (ii) Initial stored energy in first capacitor

$$U_i = \frac{1}{2} C_1 V_i^2 = \frac{1}{2} \times 0.1 \times 10^{-6} \times 10^2 = 5.0 \mu J$$

$$\Rightarrow \frac{U_f}{U_i} = \frac{2.5}{5.0} = \frac{1}{2}$$

9. $x = \frac{2x}{2+x} + 1$

(Let $C_{eq} = x$)

$$x = \frac{2x + 2 + x}{2 + x}$$

$$\Rightarrow x(2+x) = 3x + 2$$

$$\Rightarrow 2x + x^2 = 3x + 2 \Rightarrow x^2 - x - 2 = 0$$

Use

$$x = \frac{-b \pm \sqrt{b^2 - 4ac}}{2a} = \frac{1 \pm \sqrt{1+8}}{2} = \frac{1+3}{2} = 2$$

and -1

$$x = 2, C_{eq} = 2 \mu F$$

10. $C_x = \frac{\epsilon_0 A}{d}, C_y = \frac{5\epsilon_0 A}{d} \Rightarrow CY = 5CX$

- (i) C_x and C_y are in series, so charge on each

$$q = C_x V_x = C_y V_y \Rightarrow \frac{V_x}{V_y} = 5$$

$$\therefore V_x + V_y = 12 \quad \therefore 6V_y = 12$$

$$\Rightarrow V_y = \frac{12}{6} = 2 \text{ volt and } V_x = 10 \text{ volt}$$

- (ii) Energy stored in capacitor

$$U = \frac{q^2}{2C} \Rightarrow \frac{U_x}{U_y} = \left(\frac{q^2}{2C_x} \right) \left(\frac{2C_y}{q^2} \right) = \frac{C_y}{C_x} = 5$$

11. $\frac{C_A}{C_B} = \frac{\left(\frac{K_1 \epsilon_0 A}{d/4} \right)}{\left(\frac{K_2 \epsilon_0 A}{3d/4} \right)} = \frac{3K_1}{K_2} = 3 \times 3 = 9$

Net capacity

$$C = \frac{C_A C_B}{C_A + C_B} = \frac{(9C_B)(C_B)}{9C_B + C_B} = \frac{9}{10} C_B$$

$$= \frac{9}{10} \left[\frac{K_2 \epsilon_0 A}{(3d/4)} \right] = \frac{6K_2 \epsilon_0 A}{5d} = \frac{1.2K_2 \epsilon_0 A}{d}$$

12. $\therefore E = \frac{V}{d}$

$$\therefore d = \frac{V}{E} = \frac{10^3}{10^6} = 10^{-3} \text{ m}$$

Now $C = \frac{\epsilon_0 \epsilon_r A}{d}$

$$\Rightarrow A = \frac{Cd}{\epsilon_0 \epsilon_r} = \frac{88.5 \times 10^{-12} \times 10^{-3}}{8.85 \times 10^{-12} \times 10} = 10^{-3} \text{ m}^2$$

13. When S_{w1} is closed and S_{w2} is open then capacitor B is charged upto 10V.

Now S_{w1} is open and S_{w2} is closed then

$$V_{\text{common}} = \frac{C_1 V_1 + C_2 V_2}{C_1 + C_2} = \frac{3 \times 10 + 2 \times 0}{3 + 2} = 6V$$

$$Q_A = 2 \times 10^{-6} V_{cm} = 12 \mu C$$

$$Q_B = 3 \times 10^{-6} V_{cm} = 18 \mu C$$

14. $CV_1 = 3CV_2 \dots (i)$

$$V_1 + V_2 = 300 \dots (ii)$$

$$\Rightarrow V_1 = 75V; V_2 = 225V$$

$$(i) \therefore E_1 = \frac{V_1}{d_1} = \frac{75 \times 100}{0.5} = 1.5 \times 10^4 \text{ V/m}$$

$$E_2 = \frac{V_2}{d_2} = \frac{225 \times 100}{0.5} = 4.5 \times 10^4 \text{ V/m}$$

$$(ii) V_1 = 75V; V_2 = 225V$$

$$(iii) Q = \left(\frac{C_1 C_2}{C_1 + C_2} \right) V = \frac{3}{4} C, V = \frac{3}{4} \left(\frac{2\epsilon_0 A}{d} \right) 300$$

$$\Rightarrow \frac{Q}{A} = \frac{6 \times 300 \times 8.89 \times 10^{-12}}{4 \times 0.5 \times 10^{-2}} = 8 \times 10^{-7} \text{ C/m}^2$$

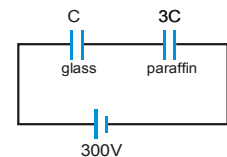
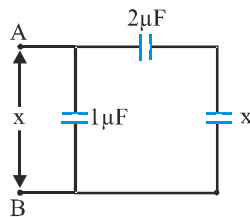

PHYSICS FOR JEE MAIN & ADVANCED

15. (a) In steady state no current in capacitor's branch.

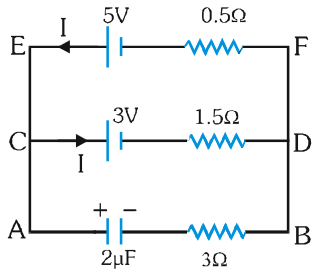

So current $I = \frac{2}{0.5 + 1.5} = 1\text{A}$

voltage across capacitor

$$V_C = 3 + 1.5 \times 1 = 4.5\text{V}$$

$$\Rightarrow Q = CV_C = 2 \times 10^{-6} \times 4.5 = 9 \times 10^{-6}\text{C}$$

16. (i) At $t = 0$, capacitor has zero resistance, i.e., R_1 and R_2 are in parallel.

The simple circuit is shown in figure

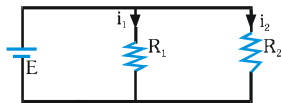

$$i_1 = \frac{E}{R_1} \quad \text{and} \quad i_2 = \frac{E}{R_2}$$

(ii) At steady state ($t = \infty$), capacitor has infinite resistance.

Hence, $i_1 = \frac{E}{R_1}$, $i_2 = 0$

(iii) Final potential difference across capacitor is E .

\therefore Final energy stored

$$U = \frac{1}{2}CE^2$$

(iv) When switch is opened, capacitor will discharge through two resistance as R_1 and R_2 (both in series).

Hence, $\tau_c = C(R_1 + R_2)$

(v) When switch is closed, capacitor will charged through resistance R_2 .

So $\tau = R_2C$

17. For the circuit ACDA and the cell :

$$6 - I_1(5) - 6 = 0 \Rightarrow I_1 = 0, \therefore I = 0$$

For the loop BCD : $V_{2\mu F} = 6\text{V}$

For the loop ABD : $V_{7\mu F} = 6\text{V}$

$$\therefore Q_{7\mu F} = 6 \times 7 = 42\mu\text{C}$$

18. $R_{\text{eff}} = \frac{2 \times 3}{3 + 2} + 2.8 = 4\Omega$

$$I = \frac{V}{R_{\text{eff}}} = \frac{6}{4} = 1.5\text{A}$$

$$\therefore I_{2\Omega} = I \left(\frac{3}{2 + 3} \right) = \frac{1.5 \times 3}{5} = 0.9\text{A}$$

19. Total heat dissipated

$$H = \frac{1}{2}CV^2 = \frac{1}{2} \times 5 \times 10^{-6} \times 200 \times 200 = 0.1\text{J}$$

$$H_1 = \text{Heat developed across } R_1 = \int I^2 R_1 dt$$

$$H_2 = \text{Heat developed across } R_2 = \int I^2 R_2 dt$$

$$\Rightarrow H_1 = \frac{(H_1 + H_2)R_1}{(R_1 + R_2)} = \frac{H R_1}{(R_1 + R_2)} = \frac{0.1 \times 500}{(500 + 330)} = 60\text{mJ}$$

20. $\frac{1}{C_{\text{arm}}} = \frac{1}{C} \left(1 + \frac{1}{2} + \frac{1}{4} + \frac{1}{8} + \dots \right) = \frac{1}{C \left(1 - \frac{1}{2} \right)} = \frac{2}{C}$

$$\therefore C_{\text{effective}} = 2C_{\text{arm}} = \frac{2C}{2} = C$$

21.

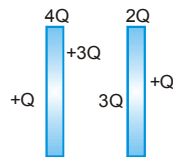

Initial effective charge = $3Q$

$$CV + CV = Q_1 + Q_2 = 3Q + 0 = 3Q$$

$$\therefore V = \frac{3Q}{2C}$$

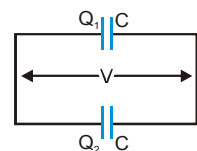

22. $V_{2\text{ initial}} = \frac{20}{2} = 10\text{V}$

$V_{5\text{ initial}} = \frac{50}{5} = 10\text{V}$

There is no potential difference.
Hence no charge flows.
Heat produce is zero.

23. $E_{\text{final}} = \frac{1}{2} \frac{Q^2}{C} = \frac{Q^2 d}{2 \epsilon_0 A}$; $E_{\text{initial}} = 0$

$\therefore \text{Heat} = -(E_{\text{initial}} - E_{\text{final}}) = \frac{Q^2 d}{2 \epsilon_0 A}$

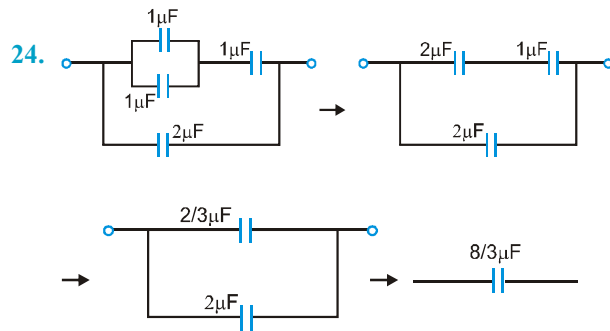

25. $\Rightarrow \frac{1}{C} + \frac{9}{32} = 1 \Rightarrow C = \frac{32}{23} \mu\text{F}$

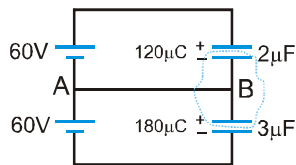
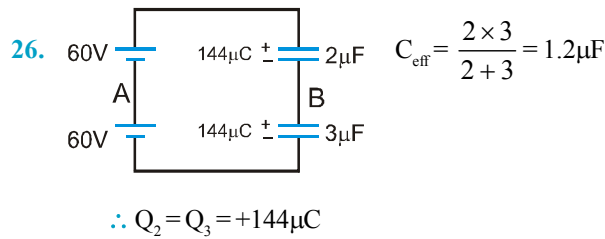

Q_{total} on the middle plates
 $= +180 + (-120) = +60 \mu\text{C}$
This charge flows from A to B.

27.

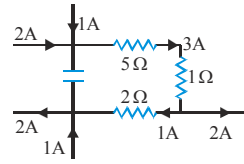

$V_c = (5 + 1) \times 3 + 2 \times 1 = 20\text{V}$

$U_{\text{cap}} = \frac{1}{2} CV^2 = \frac{1}{2} \times 4 \times 20^2 = 0.8 \text{ mJ}$

28. $\frac{q}{C} - iR = 0 \Rightarrow \frac{q}{C} + \frac{dq}{dt} R = 0 \Rightarrow q = q_0 e^{-t/RC}$

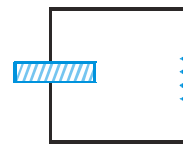

equivalent circuit $\Rightarrow i = \frac{dq}{dt} = \frac{q_0}{RC} e^{-t/RC}$

Where $R = \frac{L}{SA}$, $C = \frac{k \epsilon_0 A}{4}$

$\therefore RC = \frac{k \epsilon_0}{S} = \frac{5 \times 8.85 \times 10^{-12}}{7.4 \times 10^{-12}} = \frac{5 \times 8.85}{7.4}$

$\therefore i = \frac{q_0}{R_c} e^{-t/RC} = \frac{8.85 \times 10^{-3}}{\left(\frac{5 \times 8.85}{7.4}\right)} e^{-12/6}$

$= \frac{7.4}{5} \times \frac{1}{7.4} \text{ mA} = 0.2 \text{ mA}$

29.

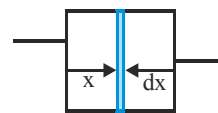

$\int \frac{1}{dC} = \int \frac{dx}{KS \epsilon_0} = \int_0^d \frac{dx}{KS \epsilon_0 \left(1 + \sin \frac{\pi x}{d}\right)}$

$\Rightarrow C = \frac{K_1 S \epsilon_0 \pi}{2d} \left[\int_0^d \frac{dx}{\left(1 + \sin \frac{\pi x}{d}\right)} = \frac{2d}{\pi} \right]$

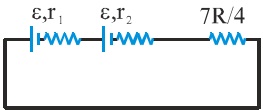
30.  $I = \frac{2\varepsilon}{r_1 + r_2 + \frac{7R}{4}}$

Pot. diff. across (ε, r_1) cell : $\varepsilon - Ir_1 = 0$

$\Rightarrow \varepsilon = Ir_1 \Rightarrow \varepsilon = \frac{2\varepsilon r_1}{r_1 + r_2 + \frac{7R}{4}} \Rightarrow \frac{4(r_1 - r_2)}{7} = R$

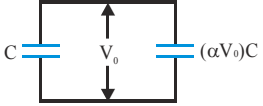
31. 

Total charge remains constant

$156C = (\alpha V_0)CV_0 + CV_0$

$\Rightarrow V_0^2 + V_0 - 156 = 0$ ($\alpha = 1$)

$\Rightarrow (V_0 + 13)(V_0 - 12) = 0 \Rightarrow V_0 = 12$ volt

32. $C_{eq} = \frac{2C}{3} + C = \frac{5C}{3}$

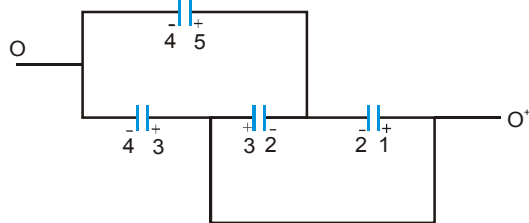

$Q_3 = \frac{4}{3} \varepsilon_0 \frac{AV_0}{d}$ & $Q_5 = \frac{2}{3} \varepsilon_0 \frac{AV_0}{d}$

33. $Q_{total} = C_1 V = \left[C_1 + \frac{C_2 C_3}{C_2 + C_3} \right] V_0$

$\Rightarrow V_0 = \frac{C_1 (C_2 + C_3) V}{C_1 C_2 + C_2 C_3 + C_3 C_1}$

\therefore Charge on C_1 ,

$q_1 = C_1 V_0 = \frac{C_1^2 V (C_2 + C_3)}{C_1 C_2 + C_2 C_3 + C_3 C_1}$

Charge on C_2 and C_3

$q_2 = q_3 = \left(\frac{C_2 C_3}{C_2 + C_3} \right) V_0 = \frac{C_1 C_2 C_3 V}{C_1 C_2 + C_2 C_3 + C_3 C_1}$

34. Extra weight needed

$= \left(\frac{6}{\varepsilon_0} \right)^2 \times \frac{\varepsilon_0 A}{2} = E_2 \times \frac{\varepsilon_0 A}{2} = \left(\frac{V}{d} \right)^2 \frac{\varepsilon_0 A}{2}$

$\Rightarrow mg = \left(\frac{5000}{5 \times 10^{-3}} \right)^2 \times \frac{8.85 \times 10^{-12} \times 100}{2 \times 100 \times 100}$

$\Rightarrow m = 4.52 \times 10^{-3}$ kg

35. Initial condition

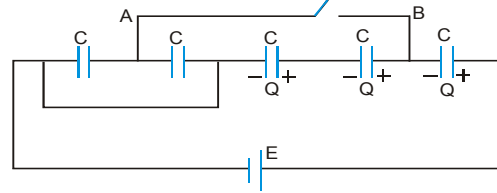

$Q = \frac{CE}{3}$

Final condition

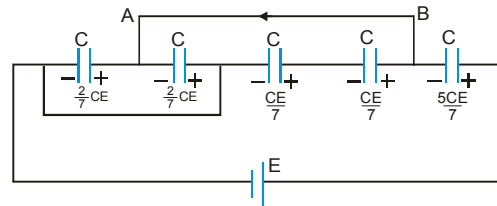

Charge flown from B to A = $\frac{4}{7} CE$

36. $Q_{pq} = 2C_2 = 6C_1 = Q_{bp}$

$\therefore V_{bp} = \frac{6C_1}{C_1} = 6V$

$\therefore V_{bq} = 6 + 2 = 8V$

Total charge flown into right loop

$= C_2 V_{bq} + C_1 V_{bp}$

$= 3C_1 \times 8 + C_1 \times 6 = 30C_1$

$\therefore V_{ab} = \frac{Q_{total}}{C_{ab}} = \frac{30C_1}{C_1} = 30$ volt

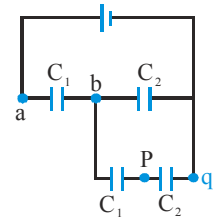

38. $V_1 C_1 = V_2 C_2$ and $V_1 + V_2 = 440$

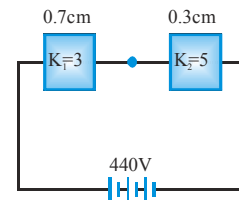

$\Rightarrow V_2 = \frac{V_1 C_1}{C_2} \Rightarrow V_1 + \frac{V_1 C_1}{C_2} = 440$

$\Rightarrow V_1 = \frac{440 C_2}{C_1 + C_2} = \frac{440}{\frac{C_1}{C_2} + 1}$

$\therefore E_1 = \frac{V_1}{d} = \frac{350 \times 100}{0.7} = 5 \times 10^4$ V/m

$$E_2 = \frac{V_2}{d} = \frac{90}{0.3} \times 100 = 3 \times 10^4 \text{ V/m}$$

$$\frac{U_1}{U_2} = \frac{\frac{1}{2} C_1 V_1^2}{\frac{1}{2} C_2 V_2^2} = \frac{35}{9}$$

39. Applying junction law at A :

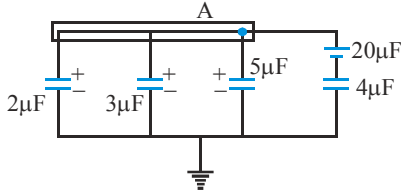

$$2(V_A - 5) + 3(V_A - 20) + 5(V_A - 10) + 4(V_A - 20) = 0$$

$$\Rightarrow V_A = \frac{100}{7} = 14.28 \text{ volt}$$

$$\therefore Q_{2\mu\text{F}} = 28.56 \mu\text{C}, Q_{3\mu\text{F}} = 42.84 \mu\text{C}, \\ Q_{5\mu\text{F}} = 71.40 \mu\text{C}, Q_{4\mu\text{F}} = 22.88 \mu\text{C}$$

40. $\frac{Q_1}{C_1} = \frac{Q_2}{C_2} \dots \text{(i)}$

$Q_1 + Q_2 = 2Q \dots \text{(ii)}$

$C_1 = \frac{\epsilon_0 A}{d - x}$ and $C_2 = \frac{\epsilon_0 A}{d + x}$

$\Rightarrow Q_2 = \frac{Q(d - x)}{d}$ and $Q_1 = \frac{Q(d + x)}{d}$

$\Rightarrow \frac{dQ_2}{dt} = -\frac{Q}{2d} \left(\frac{dx}{dt}\right)$ & $\frac{dQ_1}{dt} = \frac{Q}{2d} \left(\frac{dx}{dt}\right)$

$\therefore I = \frac{dQ_1}{dt} - \frac{dQ_2}{dt} = \frac{Q}{d} \left(\frac{dx}{dt}\right) = \frac{200}{0.1} \times 0.001 = 2 \mu\text{A}$

41. Work done by battery = $\Delta QV = (3CV)V = 3CV^2$

Energy stored in capacitors = $\frac{1}{2} (3C)V^2$

(i) \therefore Heat developed = $W_B - \Delta U = \frac{1}{2} (3C)V^2$

(ii) Work done by external agent = $-(K-1)$

(iii) Final voltage after 'dielectric is removed = V'

$$3CV' = (K+2)CV \Rightarrow V' = V \left(\frac{K+2}{3}\right)$$

$$W_{\text{agent}} = U_i - U_f$$

$$= \frac{1}{2} (3C)V^2 \left(\frac{K+2}{3}\right)^2 - \frac{1}{2} (K+2)CV^2$$

$$= \frac{(K+2)(K-1)CV^2}{6}$$

42. $C_{\text{initial}} = \frac{2C \times C}{2C + C} = \frac{2C}{3}$; $C_{\text{final}} = C$

(i) $\therefore \Delta Q = \Delta C \times V$

$$= \left(C - \frac{2C}{3}\right)V = \frac{CV}{3} = \frac{2 \times 30}{3} = 20 \mu\text{C}$$

(ii) $H = W_B - \Delta U = \Delta QV - \left(\frac{1}{2} CV^2 - \frac{1}{2} \frac{2CV^2}{3}\right)$

$$= 600 - (900 - 600) = 300 \mu\text{J} = 0.3 \text{ mJ}$$

(iii) Energy supplied by the battery

$$= \Delta QV = 600 \mu\text{J} = 0.6 \text{ mJ}$$

(iv) Initial charge on each capacitor

$$= \frac{2C}{3}V = 40 \mu\text{C}$$

Final charge on right capacitor = $60 \mu\text{C}$

Final charge on left capacitors = 0

\therefore Total charge from through switch, $S = 60 \mu\text{C}$

43. $U_1 = \frac{Q^2}{2C_1}$, $C_1 = 4\pi\epsilon_0 \left[\frac{ab}{b-a} + b\right]$

$U_2 = \frac{Q^2}{2C_2}$, $C_2 = 4\pi\epsilon_0 b$ $\therefore \Delta U = U_1 - U_2 = 9 \text{ J}$

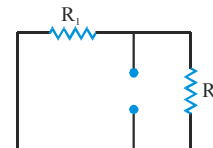

Here, R_{net} is equivalent resistance across capacitor after short circuiting the battery.

$$R_{\text{net}} = \frac{R_1 R_2}{R_1 + R_2}$$

(As R_1 and R_2 are in parallel)

$$\alpha = \frac{1}{C \left(\frac{R_1 R_2}{R_1 + R_2}\right)} = \frac{R_1 + R_2}{C R_1 R_2}$$

EXERCISE - 5

Part # I : AIEEE/JEE-MAIN

1. $C_{\text{eff(Parallel)}} = nC$

If connected across V volts then energy stored

$$= \frac{1}{2}(nC)V^2$$

2. Capacitance of an isolated sphere is

$$C = (4\pi\epsilon_0)(\text{Radius})$$

$$C = \frac{1}{9 \times 10^9} \times 1 = 0.11 \times 10^{-9} = 1.1 \times 10^{-10} \text{ F}$$

3. (2)

4. Work done = $\frac{1}{2} \frac{Q^2}{C} = \frac{1}{2} \frac{(8 \times 10^{-18})^2}{100 \times 10^{-6}}$
 $= \frac{1}{2} \times \frac{64 \times 10^{-36}}{10^{-4}} = 32 \times 10^{-32} \text{ J}$

5. $\frac{1}{2} cv^2 = ms\Delta T \Rightarrow V = \sqrt{\frac{2ms\Delta T}{C}}$

6. Two plates stacked together form a single capacitor of capacitance C. n plates stacked together form (n-1) number of capacitors of effective capacitance (n-1)C.

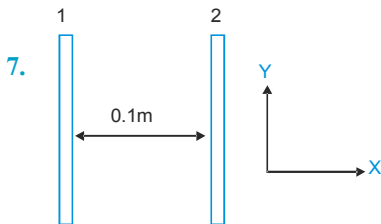

Applying law of conservation of energy

We get $\frac{1}{2} mv^2 = eV$

[Here, v = speed of electron, $V = V_2 - V_1$ = potential difference]

$$v = \sqrt{\frac{2eV}{m}} = \sqrt{\frac{2 \times 1.6 \times 10^{-19} \times 20}{9 \times 10^{-31}}}$$

On solving, we get $v = 2.65 \times 10^6 \text{ m/s}$

8. Energy stored in a capacitor when it is charged by a

potential difference of V_0 volt = $\frac{1}{2} QV_0$

Total work done by battery in sending a charge of Q through emf $V_0 = QV_0$

hence $\frac{\text{energy stored in capacitor}}{\text{work done by battery}} = \frac{\frac{1}{2} QV_0}{QV_0} = \frac{1}{2}$

9. Net work done by the system in the process is zero, as in removing the dielectric, work done is equal and opposite to the work done in re-inserting the dielectric.

10. $C = \frac{\delta A}{d} = 9 \text{ Pf}$; $C_{\text{eq}} = \frac{C_1 C_2}{C_1 + C_2}$
 $\Rightarrow \frac{\left(\frac{3\epsilon_0 AK_1}{d}\right)\left(\frac{3\epsilon_0 AK_2}{2d}\right)}{\frac{3\epsilon_0 AK_1}{d} + \frac{3\epsilon_0 AK_2}{2d}} \Rightarrow \frac{d}{2} \text{ F} = 40.5 \text{ pF}$

11. $U = \frac{1}{2} CV^2$; $\frac{U_0}{2} = \frac{1}{2} CV_0^2 e^{-2t_1/RC}$

$$\frac{1}{2} = e^{-2t_1/RC} \quad (U_0 = \frac{1}{2} CV_0^2)$$

$$\frac{2t_1}{RC} = \ln 2$$

$$t_1 = \frac{RC \ln 2}{2} \dots \text{(i) and } \frac{q_0}{4} = q_0 e^{-t_2/RC}$$

$$\frac{t_2}{RC} = 2 \ln 2; t_2 = 2RC \ln 2 \dots \text{(ii)}$$

from equation (i) and (ii) $\frac{t_1}{t_2} = \frac{1}{4}$

12. $V = V_0 (1 - e^{-t/RC}) \Rightarrow 120 = 200 (1 - e^{-\frac{5}{RC}})$
 $\Rightarrow R = 2.7 \times 10^6 \Omega$

13. Parallel Series

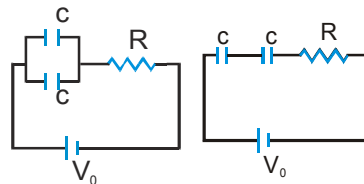

$$\frac{v_0}{2} = v_0 \left(1 - e^{-\frac{t_p}{R \times 2C}}\right) \dots \text{(i)}$$

$$\frac{v_0}{2} = v_0 \left(1 - e^{-\frac{t_s}{R \times \frac{C}{2}}}\right) \dots \text{(ii)}$$

from (i) and (ii) $e^{-\frac{t_p}{2Rc}} = e^{-\frac{2t_s}{Rc}}$

$$t_s = \frac{t_p}{4} = \frac{10}{4} = 2.5 \text{ sec}$$

14. $t = 0.37\% \text{ of } V_0$
 $= 0.37 \times 25 = 9.25 \text{ volt}$
 where is in between 100 and 150 sec.

15. Common voltage = $\frac{C_1 V_1 - C_2 V_2}{C_1 + C_2}$
 (positive plate of one capacitor is connected with negative plate of second capacitor)
 $\Rightarrow 120 C_1 = 200 C_2 \Rightarrow 3C_1 = 5C_2$

16. 3

17. $q = \left(\frac{3C}{C+3}\right)E \Rightarrow q = CV \Rightarrow q \propto C$

$q_2 = \left(\frac{3C}{C+3}\right)E \left(\frac{2}{3}\right) \Rightarrow q_2 = \left(\frac{2C}{C+3}\right)E$

$q_2 = \left(\frac{2C}{1+\frac{3}{C}}\right)E \quad q = CV \Rightarrow C \uparrow q_2 \uparrow$

If $C \rightarrow \infty$, $q = \text{constant value}$.

18.

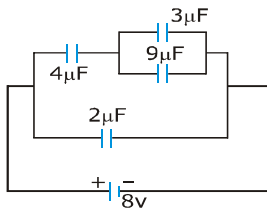

Potential at $4\mu\text{F} = 6 \text{ volt}$

$\therefore \text{charge } q_1 = 24\mu\text{C}$

Potential at $9\mu\text{F} = 2 \text{ volt}$

$\therefore \text{charge } q_2 = 18\mu\text{C}$

total $q = 42 \mu\text{C}$

$E = \frac{kq}{r^2} = \frac{9 \times 10^9 \times 42 \times 10^{-6}}{900} = 420 \text{ N/C}$

Part # II : IIT-JEE ADVANCED

Straight Objective type question

1. In steady state condition, no current will flow through the capacitor C. Current in the outer circuit,

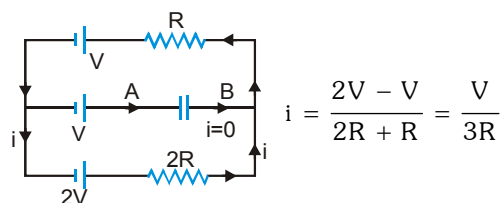

Potential difference between A and B :

$V_A - V + V + iR = V_B$

$\therefore V_B - V_A = iR = \left(\frac{V}{3R}\right)R = \frac{V}{3}$

2. Charging current $I = \frac{E}{R} e^{-\frac{t}{RC}}$

Taking log both sides $\log I = \log\left(\frac{E}{R}\right) - \frac{t}{RC}$

When R is doubled, slope of curve increase. Also at $t=0$, the current will be less. Graph Q represents the best.

3. Given: $V_C = 3V_R = 3(V - V_C)$

Here, V is the applied potential.

$\therefore V_C = \frac{3}{4}V \Rightarrow V(1 - e^{-t/RC}) = \frac{3}{4}V \quad \therefore e^{-t/RC} = \frac{1}{4}$

Here $\tau_c = cR = 10\text{s}$

Substituting this value of τ_c in equation and solving

We get : $t = 13.86 \text{ s}$

4. $\tau = CR$

$\tau_1 = (C_1 + C_2)(R_1 + R_2) = 18 \mu\text{s}$

$\tau_2 = \left(\frac{C_1 C_2}{C_1 + C_2}\right) \left(\frac{R_1 R_2}{R_1 + R_2}\right) = \frac{8}{6} \times \frac{2}{3} = \frac{8}{9} \mu\text{s}$

$\tau_3 = (C_1 + C_2) \left(\frac{R_1 R_2}{R_1 + R_2}\right) = (6) \left(\frac{2}{3}\right) = 4 \mu\text{s}$

5. From Y to X charge flows to plates a and b.

$(q_a + q_b)_i = 0, (q_a + q_b)_f = 27\mu\text{C}$

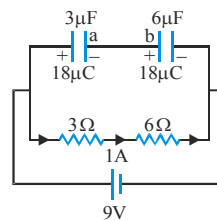

Initial Figure (when switch was open)

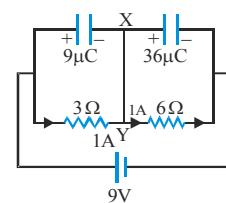

Final Figure (when switch is closed)

$\therefore 27\mu\text{C}$ charge flows from Y to X.

PHYSICS FOR JEE MAIN & ADVANCED

6. Time constant

$$\text{Where } \frac{1}{C} = \frac{1}{C_1} + \frac{1}{C_2} = \frac{\left(\frac{2d}{3} + Vt\right)}{\epsilon_0} + \frac{\left(\frac{d}{3} - Vt\right)}{2\epsilon_0}$$

$$\Rightarrow C = \frac{6\epsilon_0}{5d + 3Vt}$$

9.

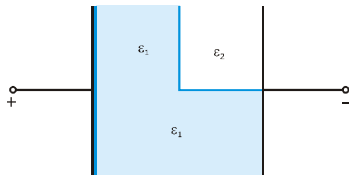

$$C_1 = \frac{\epsilon_0 A}{d} = C$$

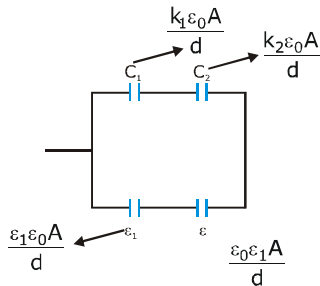

$$\frac{4}{3} + 1 = \frac{7}{3} \Rightarrow C_2 = \frac{7C}{3}$$

Multiple Correct type question

1. Before S_3 is pressed

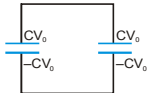

After S_3 is pressed

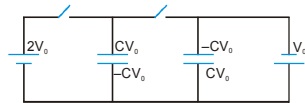

2. A, D

Subjective

1. Let at any time t charge on capacitor C be Q and currents are as shown. Since, charge Q will increase with time t .

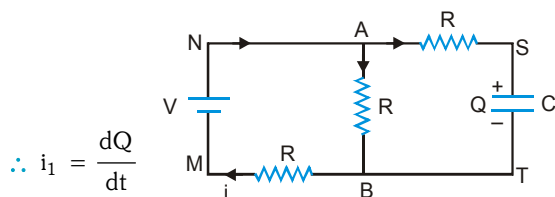

$$\therefore i_1 = \frac{dQ}{dt}$$

- (i) Applying Kirchoff's second law in loop MNABM

$$V = (i - i_1)R + iR \Rightarrow V = 2iR - i_1R \quad \dots \text{(i)}$$

Similarly, applying Kirchoff's second law in loop MNSTM

$$\text{we have } V = i_1R + \frac{Q}{C} + iR \quad \dots \text{(ii)}$$

Eliminating i from equations (i) and (ii), we get

$$V = 3i_1R + \frac{2Q}{C} \Rightarrow 3i_1R = V - \frac{2Q}{C}$$

$$\Rightarrow i_1 = \frac{1}{3R} \left(V - \frac{2Q}{C} \right) \Rightarrow \frac{dQ}{dt} = \frac{1}{3R} \left(V - \frac{2Q}{C} \right)$$

$$\Rightarrow \frac{dQ}{V - \frac{2Q}{C}} = \frac{dt}{3R} \Rightarrow \int_0^Q \frac{dQ}{V - \frac{2Q}{C}} = \int_0^t \frac{dt}{3R}$$

This equation gives

$$Q = \frac{CV}{2} (1 - e^{-2t/3RC})$$

- (ii) $i_1 = \frac{dQ}{dt} = \frac{V}{3R} e^{-2t/3RC}$

From equation (i)

$$i = \frac{V + i_1R}{2R} = \frac{V + \frac{V}{3} e^{-2t/3RC}}{2R}$$

\therefore Current through AB

$$i_2 = i - i_1 = \frac{V + \frac{V}{3} e^{-2t/3RC}}{2R} - \frac{V}{3R} e^{-2t/3RC}$$

$$i_2 = \frac{V}{2R} - \frac{V}{6R} e^{-2t/3RC} \Rightarrow i_2 = \frac{V}{2R} \text{ as } t \rightarrow \infty$$

2. Q_0 is the steady state charge stored in the capacitor.

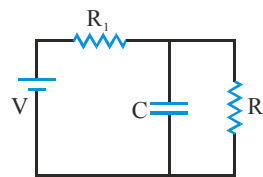

$$Q_0 = C [\text{PD across capacitor in steady state}] = C [\text{steady state current through } R_2] (R_2)$$

$$= C \left(\frac{V}{R_1 + R_2} \right) R_2$$

$$\therefore Q_0 = \frac{CV R_2}{R_1 + R_2} \propto \text{is } \frac{1}{\tau_c} \Rightarrow \frac{1}{C R_{\text{net}}}$$

MOCK TEST

1. (i) $E = \frac{2Q}{2A\epsilon_0} + \frac{Q}{2A\epsilon_0}$

$\Rightarrow E = \frac{3Q}{2A\epsilon_0}$

$E = \frac{3}{2} \frac{Q}{Cd} \Rightarrow E_d = \frac{3Q}{2C} = V$

(ii) $F = EQ/2$

$F = \left(\frac{2Q}{2A\epsilon_0}\right) \times \frac{(-Q)}{1} = -\frac{Q^2}{A\epsilon_0}$

$F = \frac{Q^2}{A\epsilon_0}$

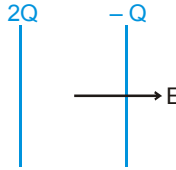

(iii) Energy = $\frac{1}{2} \epsilon_0 E_2 Ad$

$= \frac{1}{2} \epsilon_0 \left(\frac{3Q}{2Cd}\right)^2 Ad = \frac{9}{8} \frac{Q^2}{C}$

2. Equivalent circuit is

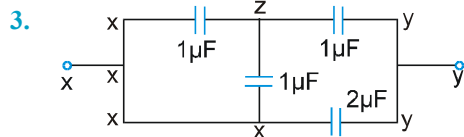
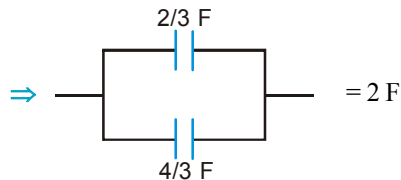
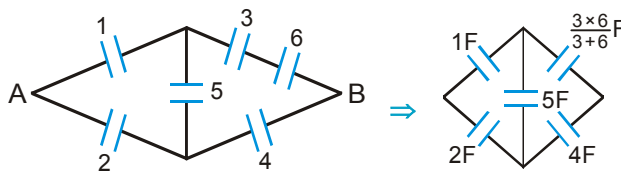

Rearrange the circuit

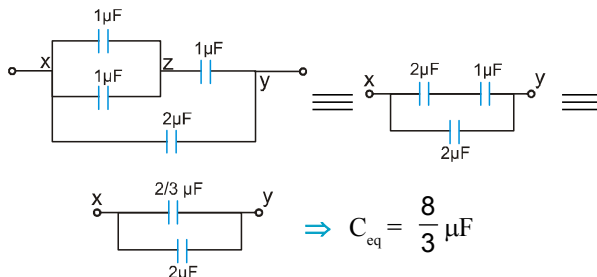

4. $V = \frac{Q_1 + Q_2}{C_1 + C_2} = 0$

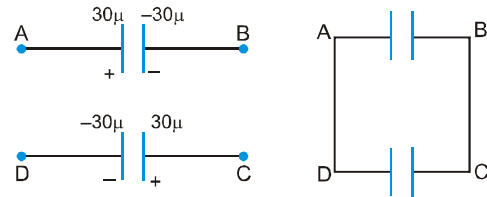

Final potential difference = zero

Final charge = Zero

Charge flow 30 μC from A to D

5.

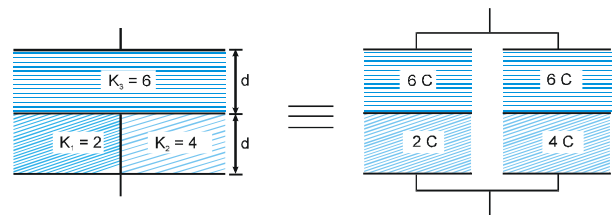

(right)

\neq

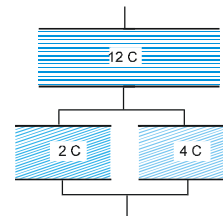

as potential difference across dielectrics of dielectric constant 2 and 4 is not same.

The equivalent capacitance $C_{eq} = \frac{2C \times 6C}{2C + 6C} + \frac{6C \times 4C}{6C + 4C} = 3.9 C$

6. Let the capacitance before insertion of dielectric be C and the resistance be R.

$\therefore q = q_0 e^{-\frac{t}{RC}}$ and $i = \frac{q/C}{R} = \frac{q}{RC}$

Just after insertion of dielectric the capacitance increases.

The charge just after insertion of dielectric remains same, but the current decreases.

\Rightarrow (A) and (B) are false

The energy stored in capacitor is $\frac{q^2}{2C}$, hence energy decreases

\Rightarrow (C) is false

The time constant is RC and hence increases.

\Rightarrow (D) is true

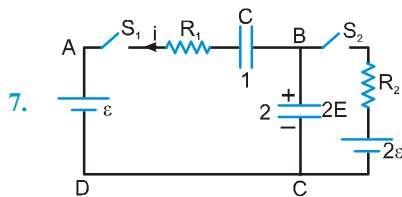

7. just before S_1 is closed the potential difference across capacitor 2 is $2E$.

just after S_1 is closed the potential difference across capacitors 1 and 2 are 0 and $2E$ respectively. Applying KVL to loop ABCD immediately after S_1 is closed.

$$E = -iR_1 + 0 + 2E$$

or $i = \frac{E}{R_1}$ towards left

8. This is a DC circuit because the battery is the only source of voltage. Hence the capacitors behave like open circuits. An equivalent circuit is then two parallel sets of two identical series resistors, see figure. The voltage drop across each parallel branch must be the battery voltage of 3V. Since the resistors are identical there is an equal voltage drop of 1.5V across each resistor. In particular there is a drop of 1.5 V across resistor A.

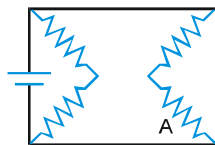

9. Rate of change of energy = $V \cdot I$.

Initially $V = 0$ hence $VI = 0$

finally $I = 0$ hence $VI = 0$

∴ first increases then decreases

10. As the key is connected to 1 and 2 frequently and at equal intervals, the two emf's E_1 & E_2 behave as d.c. sources in continuous contact.

The potential due to the two cells is :

$$V = \left(\frac{E_1 R_2 + E_2 R_1}{R_1 + R_2} \right)$$

Hence the charge on the capacitor is $q = CV$

$$= \frac{(E_1 R_2 + E_2 R_1)C}{(R_1 + R_2)}$$

11. $U_i = \frac{1}{2} C \epsilon_1^2$

$$U_f = \frac{1}{2} C \epsilon_2^2 \quad \Delta U = \frac{1}{2} C (\epsilon_2^2 - \epsilon_1^2)$$

$$Q_{in} = +C \epsilon_1 \quad ; \quad Q_{final} = -C \epsilon_2$$

$$\Delta Q = C (\epsilon_1 + \epsilon_2)$$

work done by battery $W_b = E_2 \cdot \Delta Q$

$$= C (\epsilon_2 + \epsilon_1) \epsilon_2$$

Heat generated = $W_b - \Delta U$

$$= C \epsilon_2^2 + C \epsilon_1 \epsilon_2 - \frac{1}{2} C (\epsilon_2^2 - \epsilon_1^2)$$

$$= \frac{1}{2} C (\epsilon_2^2 + \epsilon_1^2 + 2 \epsilon_1 \epsilon_2)$$

$$= \frac{1}{2} C (\epsilon_1 + \epsilon_2)^2$$

12. The equivalent circuit is as shown in figure (b).

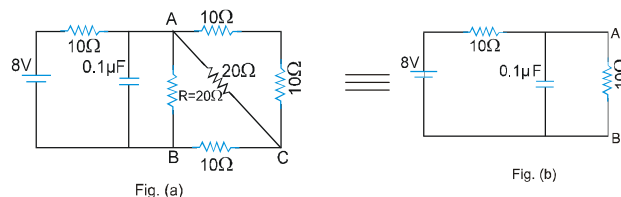

In the steady state the potential difference across AB is 4 volts.

∴ Charge on capacitor in steady state is

$$q = CV = 0.4 \mu C$$

Current through resistor R is $I = \frac{V}{R} = \frac{4}{20} = 0.2 \text{ A}$

13. $U = \frac{1}{2} C_{eq} V^2 \Rightarrow C_1 = \frac{k \epsilon_0 A}{d/2} = \frac{2 \epsilon_0 A}{(d/2)}$

$$C_{eq} = \frac{C_1 C_2}{C_1 + C_2} \Rightarrow C_2 = \frac{\epsilon_0 A}{d/2};$$

$$C_{eq} = \frac{\left(\frac{2 \epsilon_0 A}{d/2} \right) \times \frac{\epsilon_0 A}{d/2}}{3 \frac{\epsilon_0 A}{d/2}} = \frac{4 \epsilon_0 A}{3 d}$$

$$U = \frac{1}{2} \left(\frac{4 \epsilon_0 A}{3 d} \right) V^2 = \frac{2}{3} \left(\frac{\epsilon_0 A}{d} \right) V^2$$

14. Method I

Force between plates

$$F = \frac{Q^2}{2A\epsilon_0} = \frac{\left(\frac{\epsilon_0 A V}{x}\right)^2}{2A\epsilon_0} = \frac{\epsilon_0 AV^2}{2x^2}$$

where x is separation between plates
 $dW = F dx$

$$W = \int_d^{2d} \frac{\epsilon_0 AV^2}{2x^2} dx = \left[\frac{\epsilon_0 AV^2}{4x} \right]_d^{2d} = \frac{CV^2}{4} = 200 \mu J$$

Method II

$$U_f + W_B + W_{ext} = U_f + \text{loss}$$

Process is slow so energy loss is zero work done by battery = $W_B = Q_E$

$$Q = Q_f - Q_i = 20 - 40 = -20$$

$$W_B = -20 \times 20$$

$$\frac{1}{2} 2 \times 20^2 - 20 \times 20 + W_{ext} = \frac{1}{2} 1 \times 20^2 + 0$$

$$W_{ext} = 200 \mu J$$

15. Force on metal plate S due to electrostatic attraction

by plate T is $F = \frac{Q^2}{2A\epsilon_0}$

Force exerted on plate S by spring is = mg

In equilibrium $\Rightarrow \frac{Q^2}{2A\epsilon_0} = mg$ or

$$Q = \sqrt{2mgA\epsilon_0}$$

16. $C_{eff} = \frac{\epsilon_0 A}{d}$ since effective capacitance between plates A and E is zero.

$$\therefore U = \frac{1}{2} CV^2 = \frac{\epsilon_0 A}{2d} V^2$$

17. When switch S_2 is closed, due to symmetry no charge will flow through S_2 .

Alternate solution :

After closing and before closing the switch there is no change in potential of any point.

18. $I_{max} = \frac{2\epsilon}{R}$ at $t = 0$

$$I = \frac{\epsilon}{R} \text{ at } t = \infty$$

so charge on the capacitor is $C\epsilon$, when current is 50% of maximum current.

19. In the given cross-section which lies inside the capacitor plates, no charge flows. hence the required charge is 0.

20. Energy density = $\frac{1}{2} k\epsilon_0 E^2$

Since the cell remains connected, V remains unchanged (and therefore E remains unchanged)

\Rightarrow Energy density will increase k times.

21. Charge on outer surface of C = - charge on inner surface of C

Hence potential at B due to charge on conductor C = 0
 charge on outer surface of dielectric = - charge on inner surface of dielectric

\therefore Potential at B due to charge on dielectric = 0

$$\text{Potential at B due to charge on A} = \frac{Q}{4\pi\epsilon_0 b}$$

\therefore net potential at B = $\frac{Q}{4\pi\epsilon_0 b}$.

22. Let σ be the charge density of conducting plate and V be the volume of either dielectric

$$\therefore \frac{U_1}{U_2} = \frac{\left(\frac{1}{2} K_1 \epsilon_0 E_1^2\right) V}{\left(\frac{1}{2} K_2 \epsilon_0 E_2^2\right) V} = \frac{K_1 \left(\frac{\sigma}{K_1 \epsilon_0}\right)^2}{\left(\frac{\sigma}{K_2 \epsilon_0}\right)^2} = \frac{K_2}{K_1}$$

23. (C) Let us give equal and opposite charges to two wires so that they would have linear charge density as $+\lambda$ and $-\lambda$.

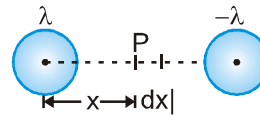

Electric field at point P,

$$E = \frac{\lambda}{2\pi\epsilon_0 x} + \frac{\lambda}{2\pi\epsilon_0 (\eta a - x)}$$

$$\int dV = -\int E dx = -\int_a^{\eta a - a} E dx$$

where a is radius of wire $\Rightarrow C = \frac{\lambda}{|V|} = \frac{\pi\epsilon_0}{\ln \eta}$

PHYSICS FOR JEE MAIN & ADVANCED

24. The resultant force acting per unit area of each plate can be written as $F = F_0 - F'$.
where F_0 is the force acting on unit area of plate due to other plate and F' is the force acting on unit area of plate from the dielectric.

$$\text{Now } F = \frac{q^2}{2\epsilon_0\epsilon A} = \frac{\left(\frac{\epsilon_0\epsilon A}{d} V\right)^2}{2\epsilon_0\epsilon A} \times \frac{1}{A} \Rightarrow F = \frac{\epsilon_0\epsilon V^2}{2d^2}$$

$$\text{Also } F_0 = F \times \epsilon$$

$$\text{So } F' = F_0 - \frac{F_0}{\epsilon} = F_0 \left(1 - \frac{1}{\epsilon}\right) = \epsilon F \left(1 - \frac{1}{\epsilon}\right) = \frac{\epsilon(\epsilon-1)\epsilon_0 V^2}{2d^2}$$

25. In steady state the capacitor is fully charged and is treated as open circuit, so no current flows through branch containing capacitor in steady state. So the circuit can be redrawn as :

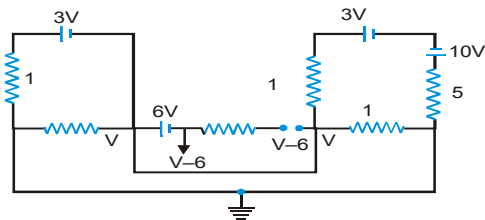

Potential difference across the capacitor in steady state

$$= V - 6 - V = -6V$$

(-ve sign signifies that left hand plate is of negative polarity)

$$\text{Charge} = CV = 1 \times 6 = 6 \mu\text{C}$$

26. As the charge of isolated system remains conserved, so the sum of charges of plates having -ve polarity remains constant. As potential of two capacitors are different so some charge flows into the circuit till both acquire the same potential.

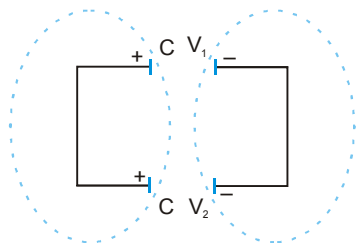

As charge flows, $\Delta H \neq 0$, and hence $\sum u_i \neq \sum U_f$

Let final common potential be V , then

$$V = \frac{C_1 V_1 + C_2 V_2}{C_1 + C_2} = \frac{V_1 + V_2}{2} \quad [\text{as } C_1 = C_2 = C]$$

27. $V_0 = I_0 R = 10 \times 10 = 100$ volts (since, $I_0 = 10$ amp from figure) Hence (A) is correct

$$\text{Also } I = I_0 e^{-t/RC}$$

$$\text{Taking log } \ln\left(\frac{I_0}{I}\right) = \frac{t}{RC}$$

$$\Rightarrow C = \frac{t}{R \ln(I_0/I)}$$

$$\text{At } t = 2 \text{ sec, } I = 2.5 A$$

$$C = \frac{2}{10 \ln\left(\frac{10}{2.5}\right)}$$

$$C = \frac{2}{10 \ln 4} = \frac{2}{10 \times 2 \ln 2} = \frac{1}{10 \ln 2} \text{ F}$$

Hence (B) is correct.

$$\text{Heat produced} = \frac{1}{2} CV^2 = \frac{1}{2} \left(\frac{1}{10 \ln 2}\right) (100)^2$$

$$= \frac{500}{\ln 2} \text{ joules.}$$

Hence (C) is correct

Thermal power in the resistor will decrease with a time constant $\frac{1}{2 \ln 2}$ second. Hence (D) is correct

28. Suppose charge flown through the battery is Q , then charge distribution will be as :

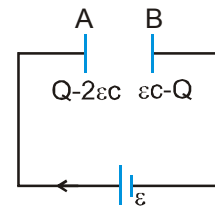

The electric field in the region between A and B is =

$$\frac{Q - 2\epsilon C}{2A \epsilon_0} - \frac{\epsilon C - Q}{2A \epsilon_0} = \frac{2Q - 3\epsilon C}{2A \epsilon_0}$$

\therefore Potential difference between the plates,

$$\frac{2Q - 3\epsilon C}{2A \epsilon_0} \cdot d = \epsilon \Rightarrow \frac{2Q - 3\epsilon C}{2} \frac{1}{C} = \epsilon \Rightarrow 2Q = 5 \epsilon C$$

$$\Rightarrow Q = \frac{5\epsilon C}{2}$$

$$\therefore \text{work done by battery} = \epsilon Q = \frac{5\epsilon^2 C}{2}$$

29. (A) $E = \frac{1}{2} CV^2$

As potential difference source between the plates is connected, p.d. remains constant. But capacitance C becomes KC hence energy stored is increased by factor K .

(B) Electric field $\frac{V}{d}$ is not changed.

(C) Charge on each plate is increased by factor K hence force between them increases by factor K^2 . For effect of the medium, they must completely lie in the medium.

(D) $Q = CV$

Hence charge becomes KQ as C becomes KC and V remain unchanged.

30. Charge on capacitor before insertion of dielectric slab = $100 \mu C$

Charge on capacitor after insertion of dielectric slab = $300 \mu C$

Increase in charge on the capacitor = $300 - 100 = 200 \mu C$

Heat produced = 0

Energy supplied by the cell = increase in stored potential energy + work done on the person who filling the dielectric slab + heat produced.

31. The instantaneous charge on the capacitor is

$$q(t) = q_0 [1 - e^{-t/RC}] = CV [1 - e^{-t/RC}]$$

The instantaneous current

$$i = \frac{dq}{dt} = CV \left(\frac{1}{RC} \right) e^{-t/RC}$$

$$\therefore i = \frac{V}{R} e^{-t/RC} \text{ or } i_0 = \frac{V}{R} \quad (\because t=0)$$

Given that V and R are same for both capacitors, so the initial current in both condensers is same moreover this is not zero.

During discharge, the instantaneous charge q is

$$q(t) = q_0 e^{-t/RC}$$

Let $q' = q_0/2$ at $t = t$, then $\frac{q_0}{2} = q_0 e^{-t/RC}$

or $t = RC \log_e 2$

If t_1 and t_2 be the times in which the two capacitors lose 50% of their charge, then

$$\frac{t_1}{t_2} = \frac{RC_1 \log_e 2}{RC_2 \log_e 2} = \frac{C_1}{C_2} = \frac{1}{2}$$

$$t_1 = t_2/2$$

This shows that C_1 loses 50% charge sooner than C_2 because it takes time t_1 which is half of t_2

32. If potential difference across an isolated charged capacitor is doubled by doubling separation between

plates, the energy stored is capacitor from $U = \frac{Q^2}{2C}$

becomes double of previous value. Hence statement-1 is false.

33. Let the electric field in region I and II be E_1 and E_2 . The potential difference across left half capacitor and right half capacitor is same.

Therefore $E_1 d = E_2 d$ where $d =$ inter planar gap.

$$\therefore E_1 = E_2$$

Hence statement - 1 is false, statement - 2 is correct by definition.

34. The electrostatic force on metal of capacitor is

$$= \text{pressure} \times \text{area of plate} = \frac{\sigma^2}{2\epsilon_0} A$$

$\sigma =$ charge per unit area on plate.

Since charge on metal plate of an "isolated" capacitor does not change, force on metal plate remains same. Electric field decreases due to induced charges in dielectric, but this does not effect the charge distribution on isolated metal plate.

35. The battery energizes the circuit and maintains the flow of electron from positive plate of capacitor to positive terminal of battery through wires and from wires to negative plate on other side.

No transfer of charge takes place within the plates in spite of having the electric field in between the plates.

36. $i = 2 \times 10^{-2} \text{ A}$

$$P_{R_1} = i^2 R_1 = (2 \times 10^{-2})^2 \times 4 \times 10^3 = 1.6 \text{ W}$$

37. $Q_{C_1} = V_{R_1} \times C_1 = 80 \times 3 \times 10^{-6} = 240 \mu C$

$$Q_{C_2} = V_{R_2} \times C_2 = 140 \times 6 \times 10^{-6} = 840 \mu C$$

38. $Q_{C_1} = EC_1 = 220 \times 3 \times 10^{-6} = 660 \mu C$

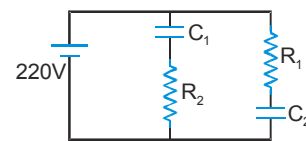

39. (C) 40. (D) 41. (C)

39. to 41.

For $t = 0$ to $t = RC$ seconds, the circuit is of charging type. The charging equation for this time is

$$q = CE(1 - e^{-\frac{t}{RC}})$$

Therefore the charge on capacitor at time $t = RC$ is

$$q_0 = CE(1 - \frac{1}{e})$$

For $t = RC$ to $t = 2RC$ seconds, the circuit is of discharging type. The charge and current equation for this time are

$$q = q_0 e^{-\frac{t-t_0}{RC}} \quad \text{and} \quad i = \frac{q_0}{RC} e^{-\frac{t-t_0}{RC}}$$

Hence charge at $t = 2RC$ and current at $t = 1.5RC$ are

$$q = q_0 e^{-\frac{2RC-RC}{RC}} = \frac{q_0}{e} = \frac{1}{e} CE(1 - \frac{1}{e})$$

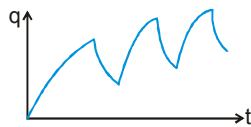

$$\text{and } i = \frac{q_0}{RC} e^{-\frac{1.5RC-RC}{RC}} = \frac{q_0}{\sqrt{e}RC} = \frac{E}{\sqrt{e}R} (1 - \frac{1}{e})$$

respectively

Since the capacitor gets more charged up from $t = 2RC$ to $t = 3RC$ than in the interval $t=0$ to $t=RC$, the graph representing the charge variation is as shown in figure

42. (A) By inserting dielectric slab, capacitance of 1 increases there by increasing charge on capacitor 2 as more charge is flown through the battery. Energy stored in capacitor also increases.
- (B) By increasing separation between the plates, capacitor C_1 decreases. Charge on C_2 also decreases.
- (C) By shorting capacitor-1, only capacitor 2 remains in the circuit. Potential difference across C_2 increases thereby increasing charge on 2 as well as energy stored.
- (D) By earthing plate of capacitor 1 potentials will change but there will be no potential difference change, making no overall change in the circuit.

43.

- (A) At constant potential difference, when interplanar separation is increased, the capacitance decreases.

From $U = \frac{1}{2} CV^2$, the potential energy decreases.

Also from $E = \frac{V}{d}$ electric field decreases

- (B) At constant charge when interplanar separation is increased the capacitance decreases.

From $U = \frac{Q^2}{2C}$, the potential energy increases

Since charge density on plates is constant, electric field remains same.

- (C) At constant potential difference, when area of plate increases the capacitance increases.

Hence from $U = \frac{1}{2} CV^2$, the potential energy increases

Also from $E = \frac{V}{d}$, the electric field remains same.

- (D) At constant charge on increase in area of plates

From $U = \frac{1}{2} \frac{Q^2}{C}$, the potential energy decreases and since charge density on plate decreases electric field decreases.

44. The initial charge on capacitor $= CV_i = 1 \times 2 \mu C = 2 \mu C$

The final charge on capacitor $= CV_f = 1 \times 4 \mu C = 4 \mu C$

\therefore Net charge crossing the cell of emf 4V is

$$q_f - q_i = 4 - 2 = 2 \mu C$$

The magnitude of work done by cell of emf 4V is

$$W = (q_f - q_i) 4 = 8 \mu J$$

The gain in potential energy of capacitor is

$$\Delta U = \frac{1}{2} C (V_f^2 - V_i^2) = \frac{1}{2} \times 1 \times [4^2 - 2^2] \mu J = 6 \mu J$$

Net heat produced in circuit is

$$\Delta H = W - \Delta U = 8 - 6 = 2 \mu J$$

45. U_i for $C_1 = C_1 \times \frac{4}{9} V_2 \times \frac{1}{2} = \frac{4V^2}{9}$

$$U_i \text{ for } C_2 = 4 \times \frac{V^2}{9} \times \frac{1}{2} = \frac{2V^2}{9}$$

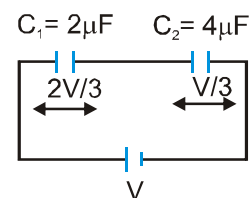

When separation of plates of C_1 gets doubled, its capacity becomes half :

$$U_f \text{ for } C_1 = 1 \times \frac{16V^2}{25} \times \frac{1}{2} = \frac{8V^2}{25}$$

$$U_f \text{ for } C_2 = 4 \times \frac{V^2}{25} \times \frac{1}{2} = \frac{2V^2}{25}$$

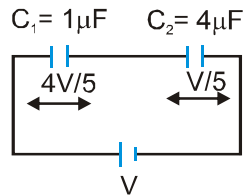

46. Energy taken from cell = $20 \times 30 \mu\text{J}$
 = $600 \mu\text{J}$

$$\text{Energy stored in capacitors} = \frac{1}{2} \cdot 3 \cdot 10^2 = 150 \mu\text{J}$$

$$\therefore \text{Heat produced in resistors} = 600 - 150 = 450 \mu\text{J}$$

Divide this heat in 2Ω and (equivalent of 3Ω and 6Ω)

i.e., in 2Ω and 2Ω

which is $225 \mu\text{J}$, $225 \mu\text{J}$

$$\therefore \text{Heat produced in } 2\Omega = 225 \mu\text{J}$$

Further divide $225 \mu\text{J}$ in 3Ω and 6Ω in inverse ratio of

$$\text{resistance} \left(\because P = \frac{V^2}{R} \right)$$

$$\text{Heat in } 3\Omega = \frac{225}{9} \times 6 = \frac{225 \times 2}{3} = 75 \times 2 = 150 \mu\text{J}$$

$$\text{Heat in } 6\Omega = \frac{225}{9} \times 3 = 75 \mu\text{J}$$

47. The charge on the capacitor when current reaches I_0

$$q_0 = (I_0 R) \cdot C_1$$

When the switch is in position 2, this charge is shared with capacitor C_2 and at steady state potential across C_1 is equal to that across C_2 . The energy lost in this process

$$\Delta U = \frac{1}{2} \cdot \frac{C_1 C_2}{C_1 + C_2} \times \left(\frac{q_0}{C_1} \right)^2 = \frac{1}{2} \cdot \frac{C_1 C_2}{C_1 + C_2} \times (I_0 R)^2 = 4 \text{ J}$$

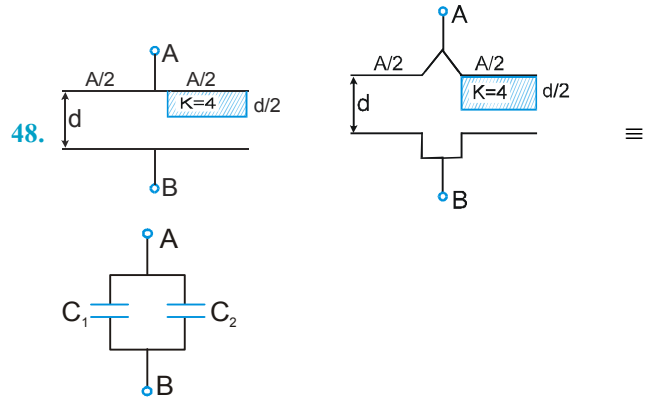

$$C_1 = \frac{\epsilon_0 A / 2}{d}, C_2 = \frac{\epsilon_0 A / 2}{\frac{d/2}{k} + \frac{d}{2}} = \frac{4\epsilon_0 A}{5d}$$

$$\Rightarrow C = C_1 + C_2 = \frac{13}{10} \frac{\epsilon_0 A}{d} \quad \text{Ans. } \frac{13}{10} \frac{\epsilon_0 A}{d}$$

49. $E < 10^6 \Rightarrow \frac{10^3}{d} < 10^6$

$$d > 10^{-3} \text{ m} \Rightarrow C = \frac{k\epsilon_0 A}{d} \Rightarrow d = \frac{k\epsilon_0 A}{C} > 10^{-3}$$

$$A > \frac{10^{-3} \times C}{k\epsilon_0} \Rightarrow A > \frac{10^{-3} \times 50 \times 10^{-12}}{(6\pi) \times \left(\frac{1}{36\pi} \times 10^{-9} \right)} = 300 \text{ mm}^2$$

50. Let each plate moves a distance 'x' from its initial position.

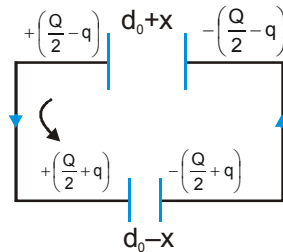

Let q charge flows in the loop. using KVL

$$\frac{\left(\frac{Q}{2} - q \right) (d+x)}{\epsilon_0 A} - \frac{\left(\frac{Q}{2} + q \right) (d-x)}{\epsilon_0 A} = 0$$

$$\therefore q = \frac{Qx}{2d_0}; I = \frac{dq}{dt} = \frac{Q}{2d_0} \left(\frac{dx}{dt} \right);$$

$$\text{Ans, } I = \frac{Qv_0}{2d_0}$$

51. Initial state

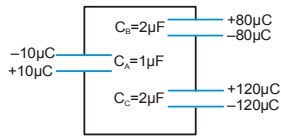

Final state

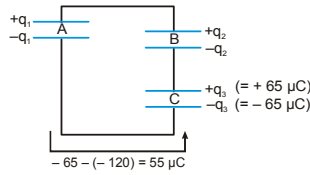

From conservation of charge

$$-q_1 - q_3 = 10 - 120 = -110 \mu\text{C} \quad \dots\dots\dots(1)$$

$$-q_2 + q_3 = -80 + 120 = +40 \mu\text{C} \quad \dots\dots\dots(2)$$

In the final state

$$\frac{q_1}{C_A} = \frac{q_2}{C_B} + \frac{q_3}{C_C}$$

$$\Rightarrow \frac{q_1}{1} = \frac{q_2}{2} + \frac{q_3}{2} \quad \text{at } q_2 + q_3 = 2q_1$$

$$\Rightarrow \frac{q_1}{1} = \frac{q_2}{2} + \frac{q_3}{2} ; q_2 + q_3 = 2q_1$$

Solving we get a $q_3 = 65 \mu\text{C}$.

The charge on lower plate of capacitor C_c changes from $-120 \mu\text{C}$ to $-65 \mu\text{C}$.

Hence the charge flowing through shown connecting wire is

$$(120 - 65) = 55 \mu\text{C}.$$

final charges

$$q_3 = 65 \mu\text{C} ; q_2 = 25 \mu\text{C} ; q_1 = 45 \mu\text{C}$$

Heat produced = $U_i - U_f$

$$= \left[\frac{(120 \mu\text{C})^2}{2 \times 2 \mu\text{F}} + \frac{(80 \mu\text{C})^2}{2 \times 2 \mu\text{F}} + \frac{(10 \mu\text{C})^2}{2 \times 1 \mu\text{F}} \right] -$$

$$\left[\frac{(65 \mu\text{C})^2}{2 \times 2 \mu\text{F}} + \frac{(25 \mu\text{C})^2}{2 \times 2 \mu\text{F}} + \frac{(45 \mu\text{C})^2}{2 \times 1 \mu\text{F}} \right] = 3025 \mu\text{J}$$

52.

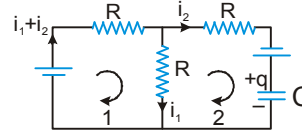

Applying Kirchoff's law in Loop 1

$$\varepsilon - (i_1 + i_2)R - i_1R = 0 \quad \dots(1)$$

Loop 2

$$-i_2R + \varepsilon - \frac{q}{C} + i_1R = 0 \quad \dots(2)$$

eliminating i_1 from (1) and (2)

$$\varepsilon - \frac{q}{C} - i_2R + \frac{\varepsilon - i_2R}{2} = 0 \quad \text{or} \quad \frac{3\varepsilon}{2} - \frac{q}{C} - \frac{3}{2}i_2R = 0$$

$$i_2 = \frac{dq}{dt} \Rightarrow \frac{3C\varepsilon - 2q}{2C} = \frac{3}{2}R \frac{dq}{dt}$$

$$\text{or} \int_0^q \frac{dq}{3C\varepsilon - 2q} = \int_0^t \frac{dt}{3RC}$$

$$\text{or} -\frac{1}{2} \ln \left(\frac{3C\varepsilon - 2q}{3C\varepsilon} \right) = \frac{t}{3RC} \quad \text{or} \quad 1 - \frac{2q}{3C\varepsilon} = e^{-\frac{2t}{3RC}}$$

$$\Rightarrow q = \frac{3C\varepsilon}{2} \left(1 - e^{-\frac{2t}{3RC}} \right) \Rightarrow i_2 = \frac{dq}{dt} = \left(\frac{\varepsilon}{R} \right) e^{-\frac{2t}{3RC}}$$

$$\text{from (1), } i_1 = \frac{\varepsilon - i_2R}{2R} = \frac{\varepsilon}{2R} \left(1 - e^{-\frac{2t}{3RC}} \right)$$

$$\text{Ans. } i = \frac{\varepsilon}{2R} \left(1 - e^{-\frac{2t}{3RC}} \right)$$