

HINTS & SOLUTIONS

EXERCISE - 1

Single Choice

1.

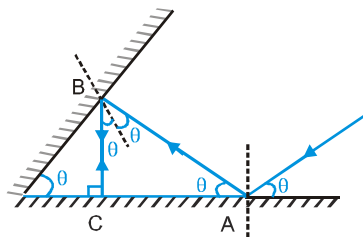

In ΔABC $90^\circ + 3\theta = 180^\circ \Rightarrow \theta = 30^\circ$

2. (B)

3. (C)

4. (C)

5.

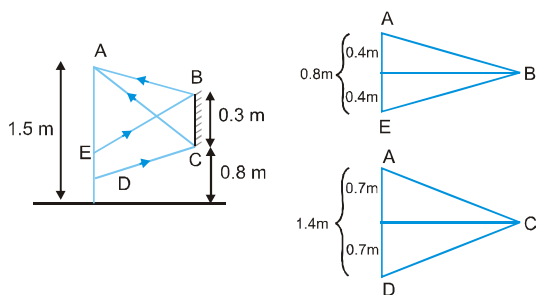

$ED = AD - AE = 1.4 - 0.8 = 0.6 \text{ m}$

6. (A)

7. (C)

8. $\vec{V}_0 = 3\hat{i} + 4\hat{j} + 5\hat{k}$ $\vec{V}_m = 8\hat{i} + 5\hat{j} + 8\hat{k}$

$V_{Iz} = 2V_{mz} - V_{oz} = 2 \times 8 - 5 = 11$

$V_{Ix} = V_{ox} = 3$

$V_{Iy} = V_{oy} = 4$

$\vec{V}_I = 3\hat{i} + 4\hat{j} + 11\hat{k}$

9. I_1 is the image formed by concave mirror.

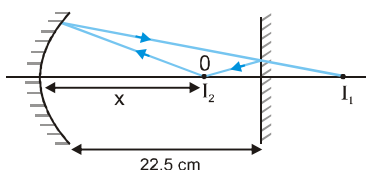

For reflection by concave mirror

$u = -x, v = -(45 - x), f = -10 \text{ cm},$

$\frac{1}{-10} = \frac{1}{-(45 - x)} + \frac{1}{-x}$

$\frac{1}{10} = \frac{x + 45 - x}{x(45 - x)} \Rightarrow x^2 - 45x + 450 = 0$

$\Rightarrow x = 15 \text{ cm}, 30 \text{ cm}$

but $x = 30 \text{ cm}$ is not acceptable because $x < 22.5 \text{ cm}$.

10. (C)

11. (C)

12. For $M_1 : v_1 = \frac{uf}{u - f} = \frac{(-30) \times (-20)}{(-30) - (-20)} = -60$

$\therefore M = -\frac{v_1}{u} = -2.$

For $M_2 : u = +20, f = 10$

$\therefore \frac{1}{v} + \frac{1}{20} = \frac{1}{10} \Rightarrow v = 20$

$\therefore m_2 = -\frac{20}{20} = -1 \therefore m = m_1 \times m_2 = +2$

13. (B)

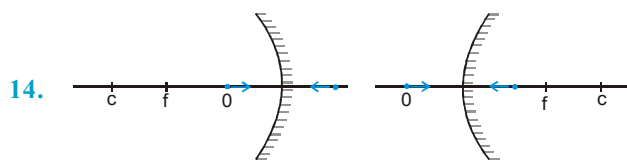

14.

only in above two cases image moves towards mirror.

15. (C)

16. Using mirror formula,

$\frac{1}{-10} = \frac{1}{v} + \frac{1}{-15} \Rightarrow v = -30 \text{ cm}.$

$|\text{Axial magnification}| = \frac{V^2}{u^2} = \left(\frac{30}{15}\right)^2 = 4$

amplitude of image = $4 \times 2 = 8 \text{ mm}.$

17. (A)

18. $\frac{I}{O} = -\frac{v}{u}$

If O and I are on same sides of PA. $\frac{I}{O}$ will be positive which implies v and u will be of opposite signs.

Similarly if O and I are on opp. sides, $\frac{I}{O}$ will be -ve which implies v and u will have same sign.

If O is on PA, $I = \left(-\frac{V}{u}\right) (O) = 0 \Rightarrow$ I will also be on P.A.

19. (C)

20. For real inverted image formed by concave mirror.
 $v = -ve, u = -ve, f = -ve$

Alternative

$$\frac{1}{v} + \frac{1}{u} = \frac{1}{f} \Rightarrow \frac{1}{v/f} + \frac{1}{u/f} = 1 \Rightarrow \frac{1}{y} + \frac{1}{x} = 1$$

$$\Rightarrow xy = x + y$$

$$\Rightarrow xy - x - y + 1 = 1 \Rightarrow (x-1)(y-1) = 1 \quad \text{Hence}$$

(A)

21. (B)

22. $i = 2r$

$$1 \sin i = n \sin r$$

$$\Rightarrow 2 \sin i/2 \cos i/2 = n \sin i/2$$

$$\Rightarrow \cos i/2 = (n/2)$$

$$\Rightarrow i = 2 \cos^{-1}(n/2)$$

23. (B)

24. As n varies 'y', parallel slabs can be taken, and we know in parallel slabs

$n_r \sin i_r = \text{constant}$. as $n_1 \sin i_1 = 1 \times \sin 90^\circ = 1 = \text{constant}$

$$n_{\text{final}} = n_{\text{air}} = 1$$

$$\Rightarrow 1 = 1 \times \sin r_{\text{final}} \Rightarrow r_{\text{final}} = 90^\circ$$

\therefore Deviation is zero.

25. (A)

26. (A)

27. $\sin \theta = \frac{1}{\mu} = \frac{C_A}{C_B} \Rightarrow C_B = \frac{V}{\sin \theta}$

28. $n_{\text{quartz}} = 2; n_{\text{glycerine}} = \frac{4}{3}$

$$\Rightarrow \frac{n_{\text{quartz}}}{n_{\text{glycerine}}} = \frac{2}{4/3} = \frac{3}{2} = \mu_{\text{rel}}$$

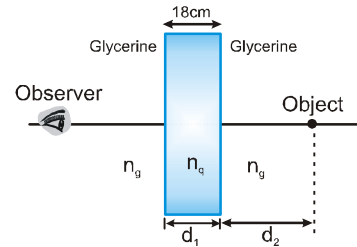

$$\text{shift} = t \left(1 - \frac{1}{\mu_{\text{rel}}}\right) = 18 \left(1 - \frac{1}{3/2}\right) = 6 \text{ cm}$$

29. $\frac{\sin i}{\sin 30^\circ} = \sqrt{2}$

$$\Rightarrow \sin i = \sqrt{2} \times \frac{1}{2} = \frac{1}{\sqrt{2}}$$

$$\Rightarrow i = 45^\circ.$$

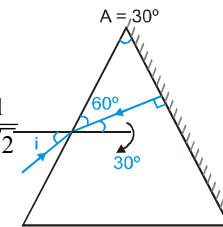

30. (B)

31. For transmission

$$r_2 \leq \sin^{-1}(1/\mu) \quad \& \quad r_1 \leq \sin^{-1}(1/\mu)$$

$$r_1 + r_2 \leq 2 \sin^{-1}(1/\mu) \quad A \leq 2 \sin^{-1}(1/\mu)$$

$$\sin^{-1}(1/\mu) \geq 45^\circ \Rightarrow \frac{1}{\mu} \geq \frac{1}{\sqrt{2}} \Rightarrow \mu \leq \sqrt{2}.$$

32. (C)

33. (A)(A) (B)(C) (C)(C)

34. $\frac{\mu_2}{v} - \frac{\mu_1}{u} = \frac{\mu_2 - \mu_1}{R} \quad \frac{\mu_2}{v} - \frac{\mu_1}{-R} = \frac{\mu_2 - \mu_1}{-R}$

$$v = -R \text{ for all values of } \mu.$$

35. (B)

36. Considering refraction at the curved surface,

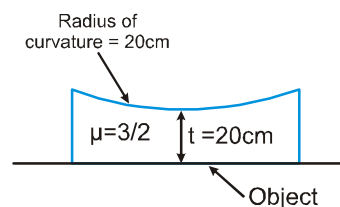

$$u = -20; \mu_2 = 1$$

$$\mu_1 = 3/2 ; R = +20$$

$$\text{applying } \frac{\mu_2}{v} - \frac{\mu_1}{u} = \frac{\mu_2 - \mu_1}{R} \Rightarrow \frac{1}{v} - \frac{3/2}{-20}$$

$$= \frac{1-3/2}{20} \Rightarrow v = -10$$

37. (A)

$$38. \frac{1}{f} = (\mu - 1) \left(\frac{1}{R_1} - \frac{1}{R_2} \right)$$

$$\Rightarrow \frac{1}{-24} = (1.5 - 1) \left(\frac{1}{2R} - \frac{1}{R} \right)$$

$$\Rightarrow \frac{1}{-24} = \frac{1}{2} \left(-\frac{1}{2R} \right)$$

$$R = 6 \text{ cm} \Rightarrow 2R = 12 \text{ cm}$$



39. (D)

$$40. P = (\mu - 1) \left(\frac{1}{R_1} - \frac{1}{R_2} \right) \quad \dots(i)$$

$$P_0 = \left(\frac{\mu}{\mu_0} - 1 \right) \left(\frac{1}{R_1} - \frac{1}{R_2} \right) \quad \dots(ii)$$

$$\frac{P}{P_0} = \frac{(\mu - 1) \mu_0}{(\mu - \mu_0)} \quad P_0 = \frac{P (\mu - \mu_0)}{\mu_0 (\mu - 1)}$$

41. (A)

42. Image of sun is formed in the focal plane. So,

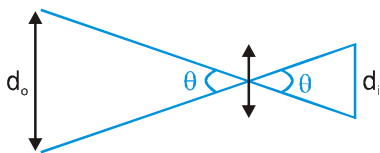

$$\text{Diameter of image} = f\theta = \frac{100 \times 0.5^\circ}{180^\circ} \times \pi \times 10 \text{ mm} = 9.$$

43. (C)

$$44. f_A = f_B = f_C = f_{\text{net}} \Rightarrow P_A = P_B = P_C = P_{\text{net}} = P$$

45. (D)

46. (B)

47. (C)

48. (A)

49. For vertical erect image by diverging lens.

u, v and f are negative

$$\therefore \frac{u}{f} = +ve \text{ and } \frac{v}{f} = +ve$$

$$\frac{1}{f} = \frac{1}{v} - \frac{1}{u} \quad 1 = \frac{f}{v} - \frac{f}{u} \Rightarrow \frac{1}{y} = \frac{1}{x} + 1$$

$y = \frac{x}{x+1}$ since x & y are +ve graph lies in first quadrant.

Also, at x = 0, y = 0 and at x = ∞, y = 1
Hence, (D)

50. (A)

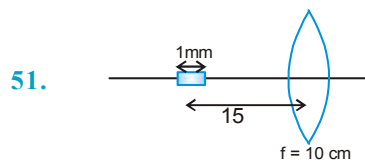

51.

$$\frac{1}{10} = \frac{1}{v} - \frac{1}{(-15)} \Rightarrow v = +30 \text{ cm}$$

$$\text{for small object } |dv| = \frac{v^2}{u^2} |du| = \left(\frac{30}{15} \right)^2 \times 1 = 4 \text{ mm}$$

52. (A)

$$53. \frac{1}{v} - \frac{1}{u} = \frac{1}{f} \Rightarrow \frac{1}{(d-u)} - \frac{1}{(-u)} = \frac{1}{f}$$

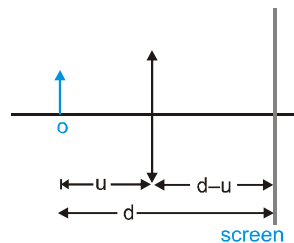

$$\Rightarrow u^2 - du + df = 0 \Rightarrow d = \frac{u^2}{(f-u)}$$

for minimum d, $u = -2f$ Hence, $d_{\text{min.}} = 4f$

54. (A)

$$55. \frac{1}{-10} = \frac{2}{-R} - \frac{2}{f_1}$$

$$\frac{2}{R} = \frac{1}{10} - \frac{2}{56} = \frac{56 - 20}{560} = \frac{36}{560}$$

$$\frac{1}{R} = \frac{18}{560}$$

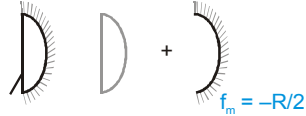

$$(\mu - 1) \frac{18}{560} = \frac{1}{56}$$

$$\mu - 1 = \frac{10}{18}$$

$$\mu = 1 + \frac{10}{18} = \frac{28}{18} = \frac{14}{9}$$

$$56. \frac{1}{f} = \frac{1}{f_1} + \frac{1}{f_2} - \frac{d}{f_1 f_2} = 0$$

$$= \frac{1}{25} + \frac{1}{-20} - \frac{d}{-500} = 0$$

$$= \frac{20 - 25}{500} = -\frac{d}{500} \quad d = 5 \text{ cm.}$$

57. (C)

$$58. C = \sin^{-1}\left(\frac{1}{\mu}\right) \quad \mu \text{ is greatest for violet}$$

$\Rightarrow C$ is minimum for violet.

59. (D)

60. (C)

61. (D)

$$62. \omega = \frac{n_v - n_r}{\left(\frac{n_v + n_r}{2}\right) - 1} = \frac{6}{25}$$

63. (D)

64. Dispersion will not occur for a monochromatic light.

65. (C)

66. (C)

67. (D)

68. In normal adjustment

$$m = -\frac{f_0}{f_e}$$

$$\text{So } 50 = -\frac{100}{f_e} \Rightarrow f_e = -2 \text{ cm}$$

(\because eyepiece is concave lens)

$$\text{and } L = f_0 + f_e = 100 - 2 = 98 \text{ cm}$$

69. (B)

$$70. m = 1 + \frac{D}{f}$$

71. (B)

72. (D)

73. (C)

$$74. f = \frac{1}{p} = \frac{1}{2} \text{ metre}$$

$f = 0.5 \text{ m}$ this is positive so lens is convex lens.

75. (C)

$$76. m_\infty = \frac{v_0}{u_0} \times \frac{D}{f_e}$$

$$\text{From } \frac{1}{f_0} = \frac{1}{v_0} - \frac{1}{u_0}$$

$$\Rightarrow \frac{1}{(+1.2)} = \frac{1}{v_0} - \frac{1}{(-1.25)} \Rightarrow v_0 = 30 \text{ cm}$$

$$\therefore |m_\infty| = \frac{30}{1.25} \times \frac{25}{3} = 200$$

77. (A)

$$78. \text{Deviation by prism} = A(\mu - 1) = 4^\circ (1.5 - 1) = 2^\circ$$

For 90° total deviation, deviation by mirror

$$= 90^\circ - 2^\circ = 88^\circ$$

$$180^\circ - 2i = 88^\circ$$

$$2i = 92^\circ$$

$$i = 46^\circ$$

Mirror should be rotated 1° anticlockwise.

79. (C)

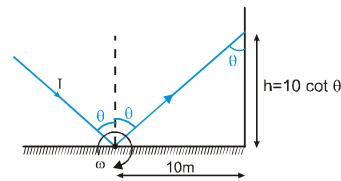

80.

When mirror is rotated with angular speed ω , the reflected ray rotates with angular speed 2ω ($= 36 \text{ rad/s}$)

$$\text{speed of the spot} = \left| \frac{dh}{dt} \right| = \left| \frac{d}{dt} (10 \cot \theta) \right|$$

$$= \left| -10 \operatorname{cosec}^2 \theta \frac{d\theta}{dt} \right| = \left| -\frac{10}{(0.6)^2} \times 36 \right| = 1000 \text{ m/s.}$$

81. (D)

82. For $m=2$

$$m = -\frac{v}{u} = 2$$

$$V = -2u \quad \dots\dots(i)$$

$$\frac{1}{f} = \frac{1}{v} + \frac{1}{u} \Rightarrow \frac{1}{f} = \frac{1}{-2u} + \frac{1}{u}$$

$$\Rightarrow \frac{1}{f} = \frac{1}{2u} \Rightarrow u = \frac{f}{2} \quad \& \quad v = -f$$

Distance between object & image = $f + f/2 = 3f/2$

For $m=-2$

$$m = -\frac{v}{u} = -2 \Rightarrow v = 2u$$

$$\Rightarrow \frac{1}{f} = \frac{1}{2u} + \frac{1}{u} \Rightarrow u = \frac{3f}{2} \quad \& \quad v = 3f$$

Distance between object & image = $3f - \frac{3f}{2}$

83. For refraction by upper surface

$$\frac{1.6}{v_1} - \frac{1}{-2} = \frac{1.6-1}{1} \Rightarrow \frac{1.6}{v_1} = 0.6 - 0.5 = 0.1$$

$$\Rightarrow v_1 = 16 \text{ m}$$

For refraction by lower surface

$$\frac{2}{v_2} - \frac{1}{-2} = \frac{2-1}{1} \Rightarrow \frac{2}{v_2} = 1 - 0.5 = 0.5$$

$$\Rightarrow v_2 = \frac{2}{0.5} = 4 \text{ m}$$

Distance between images = $(16 - 4) = 12 \text{ m}$.

84. For M_1

$$v = \frac{uf}{u-f} = \frac{-15 \times (-10)}{-15 - (-10)} = -30 \text{ cm}$$

For M_2 $u = 10 \text{ cm}$

$$\therefore v = \frac{10 \times (-10)}{10 - (-10)} = -5 \text{ cm}$$

$$\text{magnification } m = \frac{-v}{u} = -\left(\frac{-5}{10}\right) = \frac{1}{2}$$

$$\text{so, distance of image from CD} = \frac{1}{2} \times 3 = \frac{3}{2} \text{ cm}$$

$$\therefore \text{ distance of image from AB} = 3 - \frac{3}{2} = \frac{3}{2} \text{ cm}$$

85. (B)

86. (B)

87. (C)

$$88. i = \frac{\pi}{2}, e = \frac{\pi}{4}, A = \frac{\pi}{4}$$

$$\frac{\sin i}{\sin r_1} = \frac{\sin e}{\sin r_2} = \mu \Rightarrow \sin r_1 = \frac{1}{\mu}$$

$$\text{and } \sin r_2 = \frac{1}{\sqrt{2}\mu}$$

$$\text{Since } r_1 + r_2 = A = \frac{\pi}{4} \Rightarrow r_1 = \frac{\pi}{4} - r_2$$

$$\Rightarrow \sin r_1 = \frac{1}{\sqrt{2}} \cos r_2 - \frac{1}{\sqrt{2}} \sin r_2$$

$$= \sqrt{2} \sin r_1 + \sin r_2 = \cos r_2$$

$$= \frac{\sqrt{2}}{\mu} + \frac{1}{\sqrt{2}\mu} = \sqrt{1 - \frac{1}{2\mu^2}}$$

$$= \frac{1}{\mu^2} \left(2 + \frac{1}{2} + 2\right) = 1 - \frac{1}{2\mu^2}$$

$$= \frac{1}{\mu^2} \left(\frac{9}{2} + \frac{1}{2}\right) = 1$$

$$\mu^2 = 5 \Rightarrow \mu = \sqrt{5}$$

$$89. f_1 = \frac{(+20)(-40)}{(20-40)} \quad f_2 = -40$$

$$= 40$$

$$\frac{1}{f} = \frac{1}{f_1} + \frac{1}{f_2} - \frac{x}{f_1 f_2}$$

$$= \frac{1}{40} + \frac{1}{-40} - \frac{20}{40 \times (-40)}$$

$$\frac{1}{f} = \frac{1}{80}$$

$$f = 80 \text{ cm.}$$

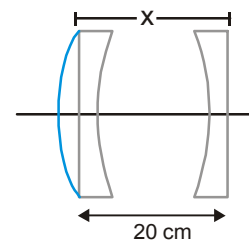

90. (A)

EXERCISE - 2

Part # I : Multiple Choice

1. (B)(D)
2. (A) No, when object is between infinite and focus, image is real.
(C) when object is between pole and focus, image is magnified.
(D) when object is between pole and focus image formed by convex mirror is real.
3. (A) is not true for minimum deviation.
(B) is true only if refracting side are equal.
(C) Two angles for maximum deviation are 90° and i_{\min} .
(D) $\delta_{\min} = (\mu - 1)A$.
4. $\delta = A \left(\frac{n_p}{n_s} - 1 \right) \Rightarrow \delta \propto A$ and $\delta \propto \left(\frac{n_p}{n_s} - 1 \right)$

5. (A)(D)
6. (B)(C)

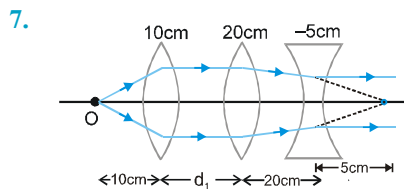

Clearly, final rays are parallel to principal axis for any value of d_1 and $d_2 = (20 - 5) = 15$ cm.

8. Convex mirror, plane mirror and diverging lens always form virtual image of a real object.
9. In fig (i) image formed by each half will have same x-coordinate but different y-coordinates. Since their principal axis are not same. And image formed by the combination of the two halves will be have different x-coordinate. Hence, three images are formed. In fig (ii) and fig. (iii), combinations have same focal length.

10. Obvious from theory

11. (A)(C)
12. (B)(C)

13. The image will look like white donkey because a small part of lines can form complete image. The image will be less intense because some light will stopped by streaks.

14. (B)(D)

15. Refer to Q.no. F-4. Ex.1, Part-I

$$f = \frac{n_1 R}{2n_2 - n_1 - n_3} \quad \text{or} \quad \frac{n_3 R}{2n_2 - n_1 - n_3}$$

$$\text{If } n_2 < \frac{n_1 + n_3}{2} \Rightarrow f \text{ is -ve} \Rightarrow \text{lens is diverging}$$

$$\text{If } n_2 > \frac{n_1 + n_3}{2} \Rightarrow f \text{ is +ve} \Rightarrow \text{lens is converging.}$$

$$\text{If } n_2 = n_1 + n_3 \Rightarrow f = \infty \text{ neither converging nor diverging.}$$

16. (A)(D)

17. (A)(B)

18. (A)(B)(C)

19. We have $v = \frac{uf}{u-f} = \frac{(-10)(10)}{-10-10} = +5$

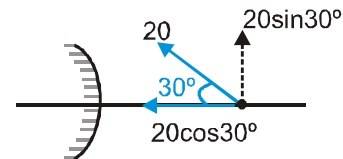

$$\therefore v_{ix} = -\frac{v^2}{u^2} v_{ox}$$

$$= -\left(\frac{5}{-10}\right)^2 \times 20 \cdot \frac{\sqrt{3}}{2} = -\frac{5\sqrt{3}}{2} \text{ mm/sec}$$

$$\text{and } v_{iy} = -\left(\frac{v}{u}\right) v_{oy}$$

$$= -\left(\frac{5}{-10}\right) \times 20 \times \frac{1}{2} = 5 \text{ mm/s.}$$

$$\text{Hence } \tan\theta = \left| \frac{v_{iy}}{v_{ix}} \right| = \frac{5}{5\sqrt{3}/2} = \frac{2}{\sqrt{3}}$$

$$\text{and } v_i = \sqrt{\left(\frac{5\sqrt{3}}{2}\right)^2 + (5)^2} = \frac{5\sqrt{7}}{2} \text{ mm/s}$$

Part # II : Assertion & Reason

- B
- From symmetry the ray shall not suffer TIR at second interface, because the angle of incidence at first interface equals to angle of emergence at second interface. Hence statement 1 is false
- D
- Draw an incident ray on the mirror and trace the corresponding reflected ray. If a point object moves along this ray, its image will always lie on the traced reflected ray. Hence when a point object moves near the principal axis of a fixed spherical mirror along a straight line, then its image formed by the spherical mirror also moves along a straight line. Statement-1 is True, Statement-2 is True; Statement-2 is a correct explanation for Statement-1.

EXERCISE - 3

Part # I : Matrix Match Type

- (A) l, s (B) j, q (C) m, r (D) k, p
- (A) For converging lens (convex lens)

$$\frac{1}{v} - \frac{1}{u} = \frac{1}{f}$$

$$u = -x, v = y, f = d \text{ (+ve constant)}$$

$$\frac{1}{y} + \frac{1}{x} = \frac{1}{d} \Rightarrow \frac{1}{y} = \frac{1}{d} - \frac{1}{x}$$

$$\text{at } x=0, y=0$$

$$\text{For } x=0 \text{ to } x=d, y = -ve$$

so, if $x \uparrow, y \downarrow$ and $|y| \uparrow$

$$\text{At } x=d, y = \infty$$

when $x > d, y +ve$, and

$$\text{at } x = \infty, y = d$$

taking magnitude of y, distance graph is shown.

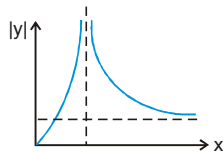

- (B) For converging mirror (concave mirror)

$$\frac{1}{v} + \frac{1}{u} = \frac{1}{f} \Rightarrow u = -x, f = -\frac{R}{2}, v = y$$

$$\frac{1}{y} - \frac{1}{x} = -\frac{2}{R} \Rightarrow \frac{1}{y} = \frac{1}{x} - \frac{2}{R}$$

$$\text{At } x=0, y=0$$

$$\text{for } 0 < x < \frac{R}{2}, y = +ve$$

and as x increases $\frac{1}{y}$ decrease so $y \uparrow$ upto $x = \frac{R}{2}$

$$\text{At } x = \frac{R}{2}, y = \infty$$

So, graph is (1)

$$\text{when } x > \frac{R}{2}, y (-ve)$$

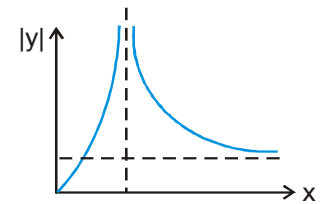

and as $x \uparrow, 1/y \downarrow, y \uparrow$ so, $|y| \downarrow$

$$\text{At } x = \infty, y = -\frac{R}{2}$$

graph breaks so graph is (1)

- (C) For diverging Lens (concave lens)

$$\frac{1}{v} - \frac{1}{u} = \frac{1}{f}$$

$$u = -x, f = -d, v = y$$

$$\frac{1}{y} + \frac{1}{x} = -\frac{1}{d}$$

$$\frac{1}{y} = -\frac{1}{x} - \frac{1}{d} \Rightarrow y \text{ is always } -ve$$

$$\text{At } x=0, y=0$$

As $x \uparrow, y \downarrow$ So, $|y| \uparrow$

$$\text{At } x=d, y = -\frac{d}{2}$$

$$\text{or } x = \infty, y = -d$$

graph is (2)

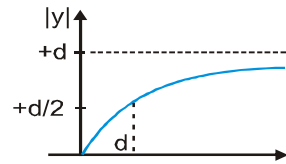

- (D) For diverging Mirror (convex mirror)

$$\frac{1}{v} + \frac{1}{u} = \frac{1}{f}$$

$$u = -x, f = +\frac{R}{2}, v = y$$

$$\frac{1}{y} - \frac{1}{x} = \frac{2}{R} \Rightarrow \frac{1}{y} = \frac{1}{x} + \frac{2}{R} \Rightarrow y = +ve$$

$$\text{At } x=0, y=0$$

$$\frac{dy}{dx} = \frac{y^2}{x^2}$$

$x \uparrow, y \uparrow$

$$\text{At } x = \frac{R}{2}, y = \frac{R}{4},$$

$$\text{At } x = \infty, y = m \frac{R}{2}$$

taking magnitude of y distance graph is graph is (2)

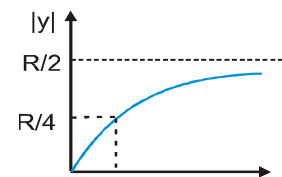

3. For spherical mirror, line joining object and its image crosses principal axis at centre of curvature. The line joining object and image inverted about principal axis cuts the principal axis at the pole. The from figure bellows

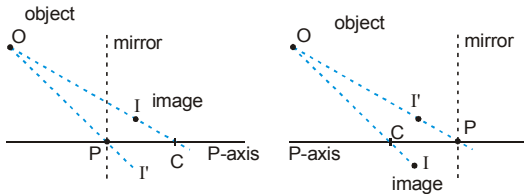

We can conclude

- (A) If object and image are on same side of principal axis, they are on opposite side of mirror.
 (B) If object and image are on opposite side of principal axis, they are on same side of mirror.
 For a lens, the line joining object and image cuts the principal axis at optical centre.
 Then from figures below.

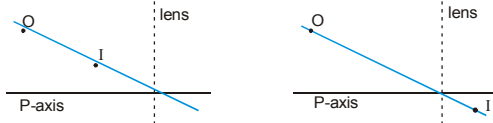

We can conclude

- (C) If object and image are on same side of principal axis, they are also on same side of lens.
 (D) If object and image are on opposite side of principal axis. They are also on opposite side of lens.

Part # II : Comprehension

Comprehension # 1

1. $\frac{1}{f} = \frac{1}{v} - \frac{1}{u}$

Here $v = 2.5$ (Distance of Retina as position of image is fixed)

$u = -x$

$\frac{1}{f} = \frac{1}{2.5} + \frac{1}{x}$

For f_{\min} : x is minimum $\frac{1}{f_{\min}} = \frac{1}{2.5} + \frac{1}{25}$

2. For f_{\max} : x is maximum $\frac{1}{f_{\max}} = \frac{1}{2.5} + \frac{1}{\infty}$

3. For near sighted man lens should make the image of the object with in 100 cm range
 For lens $u = -\infty$ $v = -100$

$\frac{1}{f_{\text{lens}}} = \frac{1}{-100} - \frac{1}{-\infty}$

4. For far sighted man lens should make image of the nearby object at distance beyond 100 cm
 For grown up person least distance is 25 cm for lens $u = -25$, $v = -100$

$\frac{1}{f} = \frac{1}{-100} - \frac{1}{(-25)} \Rightarrow \frac{1}{f} = \frac{3}{100}$

$P = +3$ so no. of spectacle is $= +3$.

Comprehension # 2

1. (D) 2. (C) 3. (D) 4. (B)
 5. (D)

EXERCISE - 4

Subjective Type

1. Angle turned by the reflected ray $= 2(20^\circ) - (10^\circ) = 30^\circ$ clockwise.

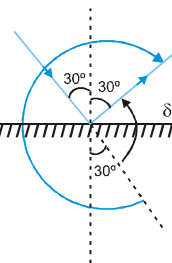

- 2.. $\delta = 180^\circ - 60^\circ = 120^\circ$
 240°

$\delta = 120^\circ$ Anticlockwise $= (360^\circ - 120^\circ)$ clockwise.

3. $2i_1 + 2i_2 + \theta = 180^\circ$ (i)

$90^\circ - i_1 + 90^\circ - i_2 + 60^\circ = 180^\circ$

$i_1 + i_2 = 60^\circ$ (ii)

from eq. (i) and (ii)

$120^\circ + \theta = 180^\circ$

$\theta = 60^\circ$

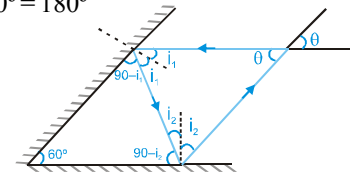

4. (A) 1; (B) (4, 0); (C) No

5. case 1

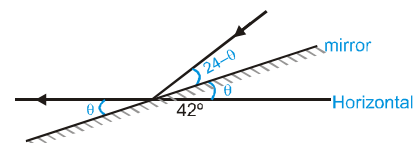

$24 - \theta = \theta$ $\theta = 12^\circ$

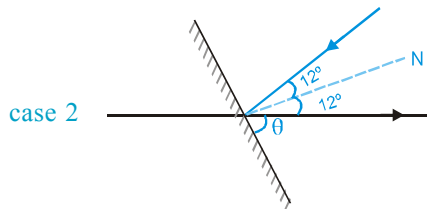

$$\theta + 12^\circ = 90^\circ \Rightarrow \theta = 78^\circ$$

6. Moon acts as object at infinity, so image is formed at focus.

$$7. |m| = \left| \frac{d_i}{d_o} \right| = \left| \frac{-v}{u} \right| \Rightarrow d_i = \left| \frac{-v}{u} \right| d_o = \frac{11.4 \times 3450}{3.8 \times 10^8} \text{ km}$$

$$= 10.35 \text{ cm}$$

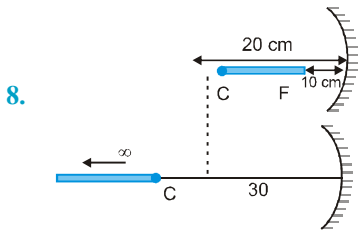

Image of end f and C is formed at infinity and C respectively

Hence image is of infinite length.

9. 84 cm, 0.5 cm

$$10. m = -\frac{v}{u} = 1.5 \quad v = -1.5 u$$

$$v = -1.5 \times (-20) = 30 \text{ cm}$$

$$\frac{1}{f} = \frac{1}{30} + \frac{1}{-20} = \frac{2-3}{60} \quad f = -60 \text{ cm.}$$

11. $u = +40 \text{ cm} \quad f = -40 \text{ cm}$

$$\frac{1}{-40} = \frac{1}{v} + \frac{1}{40} \quad \frac{1}{v} = -\frac{1}{20}$$

$$\Rightarrow v = -20 \text{ cm}$$

So required position is 0.2 m form the mirror's pole.

12. (A) 40 cm/s opposite to the velocity of object.

- (B) 20 cm/s opposite to the velocity of object.

13. Emergent ray is parallel to incident Ray, angle of emergence = 45°

$$\mu = \frac{\sin 45}{\sin r} = 1.5$$

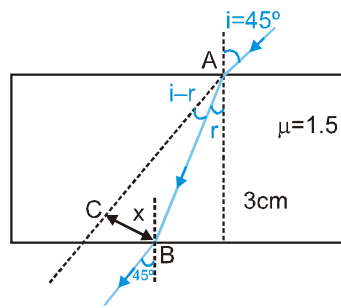

$$\sin r = \frac{1}{\sqrt{2} \times 1.5} = \frac{\sqrt{2}}{3}$$

$$AB = \frac{3}{\cos r} \quad x = AB \sin(i - r)$$

$$= \frac{3 \left[\frac{1}{\sqrt{2}} \times \frac{\sqrt{7}}{3} - \frac{1}{\sqrt{2}} \times \frac{\sqrt{2}}{3} \right]}{\frac{\sqrt{7}}{3}} = 3 \left[\frac{1}{\sqrt{2}} - \frac{1}{\sqrt{7}} \right] \text{ cm}$$

14. $\mu = \frac{\sin 30^\circ}{\sin 15^\circ}$

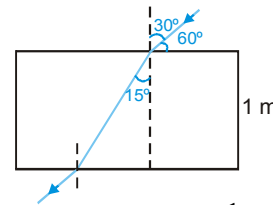

$$\text{Distance travelled by light in slab} = \frac{1 \text{ m}}{\cos 15^\circ}$$

$$\text{speed of light in slab} = \frac{C}{\mu}$$

$$t = \frac{1 / \cos 15^\circ}{C / \mu}$$

$$= \frac{\mu}{C \cos 15^\circ} = \frac{2 \sin 30^\circ}{2 \sin 15^\circ \cdot 3 \times 10^8 \cos 15^\circ}$$

$$= \frac{2 \times 1/2}{1/2 \times 3 \times 10^8} = \frac{2}{3} \times 10^{-8} \text{ sec.}$$

15. 25 cm.

16. 30 cm

17. Apparent shift = $t \left(1 - \frac{1}{\mu} \right) = 10 \left(1 - \frac{1}{2} \right) = 5 \text{ cm}$
towards slab.

$$\text{Apparent distance} = 10 + 10 + 20 - 5 = 35 \text{ cm.}$$

18. Apparent shift = 1.4

$$\left(1 - \frac{1}{1.4}\right) + 2 \left(1 - \frac{1}{1}\right) + 1.3 \left(1 - \frac{1}{1.3}\right) + 2 \left(1 - \frac{1}{1}\right) +$$

$$1.2 \left(1 - \frac{1}{1.2}\right) + 2 \left(1 - \frac{1}{1}\right)$$

= 0.4 + 0.3 + 0.2 = 0.9 cm towards the eye.

So image is formed 0.9 cm above P.

19. Apparent shift = $25 \left(1 - \frac{2}{3}\right) + 15 \left(1 - \frac{2}{5}\right) = \frac{52}{3}$ cm.

towards A

$$\text{Apparent depth} = \left(25 + 15 - \frac{52}{3}\right) = \frac{68}{3} \text{ cm}$$

20. Light comes in air from water where refraction takes place.

$$\sin i_c = \frac{R}{\sqrt{R^2 + h^2}} = \frac{1}{\mu}$$

$$\mu^2 R^2 = R^2 + h^2$$

$$R^2 = \frac{h^2}{\mu^2 - 1}$$

$$\text{Area} = \pi R^2 = \frac{\pi h^2}{\mu^2 - 1}$$

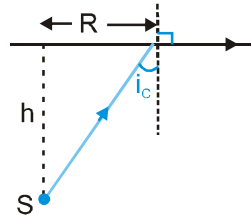

21. Applying Snell's law : $\sqrt{3} \sin 30^\circ = 1 \times \sin r$

$$\Rightarrow r = 60^\circ$$

$$\tan r = \frac{AP}{AI}$$

$$\Rightarrow \sqrt{3} = \frac{3}{AI}$$

$$AI = \sqrt{3} \text{ cm}$$

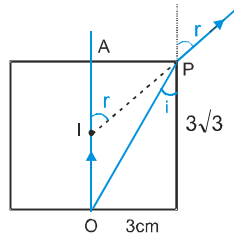

22. $i > \sin^{-1} \left(\frac{1}{\mu}\right)$

$$\sin \frac{\pi}{4} > \frac{1}{\mu}$$

$$\Rightarrow \mu > \frac{1}{\sin \frac{\pi}{4}} \Rightarrow \mu > \sqrt{2}$$

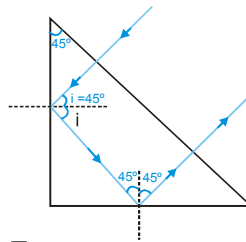

23. 45°

24. Here $i_c = \sin^{-1} \frac{1}{1.5} = \sin^{-1} \frac{2}{3} < 60^\circ$

So, T.I.R. takes place at second surface

$$\theta + 120^\circ = 180^\circ \quad \theta = 60^\circ$$

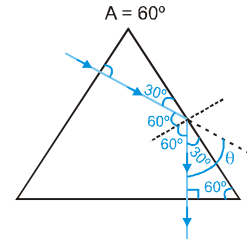

25. 90°

26. (i) 1.5° , (ii) $\frac{3^\circ}{8}$

27. For refraction at spherical surface

$$\frac{\mu_2}{v} - \frac{\mu_1}{u} = \frac{\mu_2 - \mu_1}{R} \Rightarrow \frac{2}{v} - \frac{1}{-10} = \frac{2-1}{+20}$$

$$\Rightarrow \frac{2}{v} + \frac{1}{10} = \frac{1}{20} \Rightarrow \frac{2}{v} = -\frac{1}{20}$$

$$\Rightarrow v = -40 \text{ cm. (virtual)}$$

Using magnification formula.

$$m = \frac{h_2}{h_1} = + \left(\frac{\mu_1}{\mu_2}\right) \left(\frac{v}{u}\right) \Rightarrow \frac{h_2}{2} = \frac{1 \times (-40)}{2 \times (-10)}$$

$$\Rightarrow h_2 = +4 \text{ cm. (erect)}$$

28. (A)

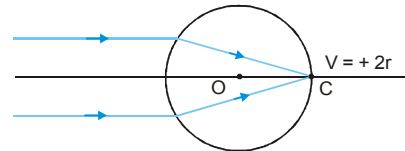

$$\frac{\mu_2}{v} - \frac{\mu_1}{u} = \frac{\mu_2 - \mu_1}{R} \Rightarrow \frac{\mu}{2r} - \frac{1}{-\infty} = \frac{\mu-1}{r}$$

$$\Rightarrow \frac{\mu}{2r} = \frac{\mu-1}{r} \Rightarrow \mu = 2\mu - 2 \Rightarrow \mu = 2$$

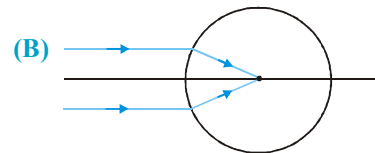

$$\frac{\mu}{r} - \frac{1}{-\infty} = \frac{\mu-1}{r} \Rightarrow \frac{\mu}{r} = \frac{\mu-1}{r} \Rightarrow \mu = \mu - 1$$

$$\Rightarrow 0 = -1 \text{ not possible}$$

29. For first refraction :

$$\frac{1.5}{v_1} - \frac{1}{-10} = \frac{1.5-1}{10} \Rightarrow v_1 = -30 \text{ cm.}$$

For second refractions

$$u = -(30+20) = -50 \text{ cm}$$

$$\therefore \frac{1}{v_2} - \frac{1.5}{-50} = \frac{1-1.5}{-10} \Rightarrow v_2 = 50 \text{ cm}$$

Hence, final image is formed 50 cm right of B.

30. When seen from air through nearest surface,

$$\frac{1}{-5} - \frac{2}{u} = \frac{1-2}{-20}$$

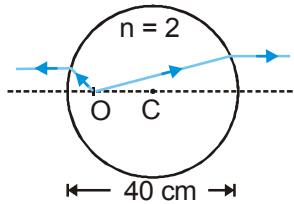

$$\frac{2}{u} - \frac{2}{u} = \frac{-1}{20} - \frac{1}{5} = \frac{-1-4}{20}$$

$$u = -8 \text{ cm.}$$

for second case, $u = -(40-8) = -32 \text{ cm}$

$$\frac{1}{v} - \frac{2}{-32} = \frac{1-2}{-20}$$

$$\Rightarrow \frac{1}{v} = -\frac{1}{16} + \frac{1}{20} = \frac{-5+4}{80}$$

$$v = -80 \text{ cm.}$$

31. $\pm 12 \text{ cm, } \pm 60 \text{ cm}$

32. For first refraction, (at the glass-water interface)

$$\frac{4/3}{v} - \frac{3/2}{-7.5} = \frac{4/3-3/2}{-5}$$

$$\frac{4}{3v} + \frac{3}{15} = \frac{1}{30}$$

$$\frac{4}{3v} = \frac{-5}{30}$$

$$\Rightarrow v = -8 \text{ cm}$$

For second refraction : (at air-water interface)

$$\text{Apparent depth} = \frac{(10+8)}{4/3} = \frac{18 \times 3}{4}$$

$$= \frac{54}{4} = \frac{27}{2} \text{ cm.}$$

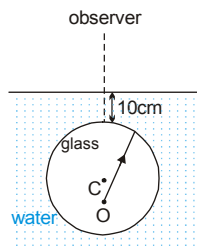

$$33. \frac{n_2}{v} - \frac{n_1}{u} = \frac{n_2 - n_1}{R}$$

$$\frac{1}{v} - \frac{3}{2 \times (-15)} = \frac{1-3/2}{-10}$$

$$\frac{1}{v} + \frac{1}{10} = \frac{-1}{10}$$

$$\Rightarrow v = -20 \text{ cm (virtual)}$$

$$-\frac{n_2}{v^2} dv + \frac{n_1}{u^2} du = 0$$

$$\frac{1}{400} dv = \frac{3}{2 \times 225} \times 1 \text{ mm}$$

$$dv = \frac{400}{2 \times 75} \text{ mm} = \frac{8}{3} \text{ mm}$$

$$\Rightarrow +ve \text{ } dv \Rightarrow \text{no inversion}$$

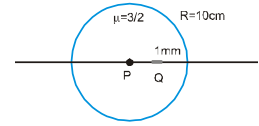

34. Converging ; real

$$35. \frac{1}{f_1} = \left(\frac{2}{1.5} - 1\right) \left(\frac{1}{-60} - \frac{1}{-40}\right) \Rightarrow f_1 = 360 \text{ cm}$$

$$\frac{1}{f_2} = \left(\frac{2}{2} - 1\right) \left(\frac{1}{-60} - \frac{1}{-40}\right) = 0 \Rightarrow f_2 = \infty$$

$$\frac{1}{f_3} = \left(\frac{2}{2.5} - 1\right) \left(\frac{1}{-60} - \frac{1}{-40}\right) \Rightarrow f_3 = -600 \text{ cm}$$

$$36. P = 5 D \Rightarrow f = \frac{1}{5} \text{ m} = 20 \text{ cm}$$

By lens formula

$$\frac{1}{f} = \frac{1}{v} - \frac{1}{u} \Rightarrow \frac{1}{20} = \frac{1}{v} - \frac{1}{-25} \Rightarrow \frac{1}{v} = \frac{1}{20} - \frac{1}{25}$$

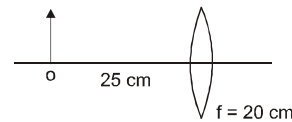

$$\Rightarrow \frac{1}{v} = \frac{5}{20 \times 25} \Rightarrow v = 100 \text{ cm} = 1 \text{ m}$$

$$m = \frac{h_2}{h_1} = +\frac{v}{u} = \frac{100}{-25} = -4 \Rightarrow h_2 = -4 \text{ cm.}$$

$$37. \text{(A)} \frac{\mu_3 R}{2\mu_2 - \mu_1 - \mu_3}$$

$$\text{(B)} \frac{\mu_1 R}{2\mu_2 - \mu_1 - \mu_3}$$

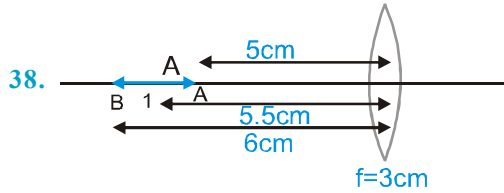

38.

For A

$$\frac{1}{3} = \frac{1}{v_A} - \frac{1}{-5} \Rightarrow \frac{1}{v_A} = \frac{1}{3} - \frac{1}{5} = \frac{2}{15}$$

$$\Rightarrow v_A = 7.5 \text{ cm.}$$

For B

$$\frac{1}{3} = \frac{1}{v_B} - \frac{1}{-6} \Rightarrow \frac{1}{v_B} = \frac{1}{3} - \frac{1}{6} = \frac{1}{6}$$

$$\Rightarrow v_B = 6 \text{ cm.}$$

$$\text{size of image} = v_A - v_B = 1.5 \text{ cm.}$$

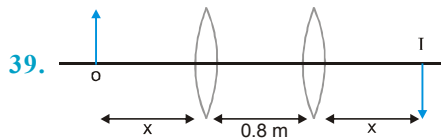

39.

for first position

$$m = \frac{v}{u} = \frac{0.8 + x}{-x} = -3 \Rightarrow 0.8 + x = 3x \Rightarrow x = 0.4$$

$$\Rightarrow \frac{1}{f} = \frac{1}{v} - \frac{1}{u}$$

$$\Rightarrow \frac{1}{f} = \frac{1}{1.2} - \frac{1}{-0.4}$$

$$\Rightarrow \frac{1}{f} = \frac{1}{1.2} + \frac{1}{0.4} = \frac{1+3}{1.2} \Rightarrow 0.3 \text{ m}$$

40. $f = \frac{1}{P} = \frac{1}{2.5} \text{ m} = 40 \text{ cm} \Rightarrow m = \frac{v}{u} = 4$

$$\Rightarrow v = 4u.$$

Using lens formula

$$\frac{1}{40} = \frac{1}{4u} - \frac{1}{u} = \frac{1-4}{4u} \quad \frac{1}{40} = \frac{-3}{4u}$$

$$\Rightarrow u = -30 \text{ cm}$$

So, required distance = 30 cm.

41. 0.4 cm

42. $\frac{5}{3}$ cm from the lens

43.

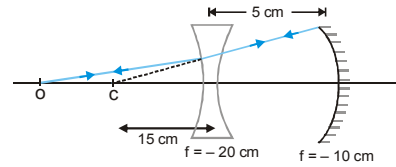

Image is formed at the object itself if the image formed due to lens is at centre of curvature of the mirror.

For refraction by lens,

$$\frac{1}{-20} = \frac{1}{-15} - \frac{1}{u} \Rightarrow u = -60 \text{ cm}$$

44. 1.0 cm if the light is incident from the side of concave lens and 2.5 mm if it is incident from the side of the convex lens and the corresponding ratio of intensities are 1/4 and 4.

45. Case-1

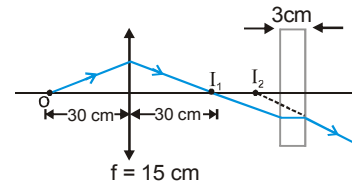

Case-2

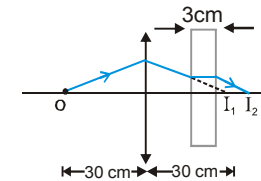

For refraction by lens

$$\frac{1}{15} = \frac{1}{v} - \frac{1}{-30} \Rightarrow \frac{1}{v} = \frac{1}{15} - \frac{1}{30} \Rightarrow v = 30 \text{ cm}$$

$$\text{apparent shift by plate} = 3 \left(1 - \frac{1}{3/2} \right) = 1 \text{ cm.}$$

Distance of final image from lens = (30 + 1) cm = 31 cm.

46. 10 cm for convex lens and 60 cm for concave lens

47. $u = -12.5 \text{ cm}, m = \frac{v}{u} = -4 \Rightarrow v = +50$

$$\text{Also, } \frac{1}{f} = \frac{1}{v} - \frac{1}{u}$$

$$\Rightarrow \frac{1}{f} = \frac{1}{+50} - \frac{1}{-12.5} = \frac{+1+4}{50} = \frac{1}{10}$$

$$f = 10 \text{ cm} = \frac{1}{10} \text{ m} \Rightarrow P = \frac{1}{f} = 10 \text{ D.}$$

$$\text{Power of each lens} = \frac{P}{2} = 5 \text{ D.}$$

48. (A) $\frac{1}{4} = 0.25$ (B) 0.90

49. (A)

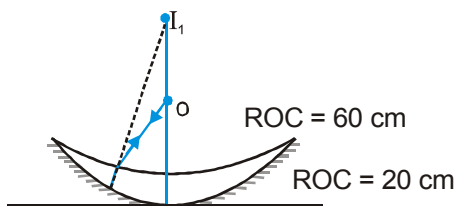

First image should form at centre of curvature of mirror after refraction by concave surface.

$$\frac{1.5}{-20} - \frac{1}{u} = \frac{1.5-1}{-60} \Rightarrow \frac{1}{u} = \frac{1}{120} - \frac{1.5}{20} = \frac{1-9}{120}$$

$$\Rightarrow u = -\frac{120}{8} = -15 \text{ cm.}$$

(B) After refraction by water lens image should form at 15 cm (Answer of part a)

$$\frac{1}{f_{\text{water}}} = \frac{1}{-15} - \frac{1}{u} = \left(\frac{4}{3} - 1\right) \left(\frac{1}{\infty} - \frac{1}{-60}\right)$$

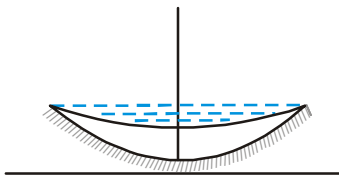

$$\Rightarrow u = -13.86 \text{ cm}$$

\Rightarrow So, distance through which the pin should be moved = $(15 - 13.86) = 1.14 \text{ cm}$ towards lens.

50. (A) $\frac{2(\mu_v - \mu_r)}{\mu_v' - \mu_r'}$, (B) $\frac{2(\mu_y - 1)}{\mu_y' - 1}$

51. Since deviation of mean ray is zero.

$$A_1(\mu_{m1} - 1) = A_2(\mu_{m2} - 1)$$

$$6^\circ(1.6 - 1) = A_2(1.9 - 1)$$

$$A_2 = \frac{6^\circ \times 0.6}{0.9} = 4^\circ$$

52. Assume microscope in normal use i.e., image at 25 cm. Angular magnification of the eye-piece

$$= \frac{25}{5} + 1 = 6$$

$$\text{Magnification of the objective} = \frac{30}{6} = 5$$

$$\frac{1}{5u_0} - \frac{1}{u_0} = \frac{1}{1.25}$$

which gives $u_0 = -1.5 \text{ cm}$; $v_0 = 7.5 \text{ cm}$. $|u_0| = (25/6) \text{ cm} = 4.17 \text{ cm}$. The separation between the objective and the eye-piece should be $(7.5 + 4.17) \text{ cm} = 11.67 \text{ cm}$. Further the object should be placed 1.5 cm from the objective to obtain the desired magnification.

53. 24; 150 cm

54. (A) $v_e = -2.5 \text{ cm}$ and $f_e = 6.25 \text{ cm}$ give $u_e = -5 \text{ cm}$;
 $v_0 = (15 - 5) \text{ cm} = 10 \text{ cm}$.
 $f_0 = u_0 = -2.5 \text{ cm}$;

$$\text{Magnifying power} = \frac{10}{2.5} \times \frac{25}{5} = 20$$

(B) $u_e = -6.25 \text{ cm}$, $v_0 = (15 - 6.25) \text{ cm} = 8.75$, $f_0 = 2.0 \text{ cm}$.
 Therefore

$$u_0 = -(70/27) = -2.59 \text{ cm.}$$

$$\text{Magnifying power} = \frac{v_0}{|u_0|} \times (25/6.25) = \frac{27}{8} \times 4 = 13.5$$

55. (A) Angular magnification = $\frac{15}{0.01} = 1500$

(B) If d is the diameter of the image (in cm).

$$\frac{d}{1500} = \frac{3.48 \times 10^6}{3.8 \times 10^8} \text{ i.e., } d = 13.7 \text{ cm}$$

56. 3 m

57. From figure, ΔEMP and ΔPOS are similar.

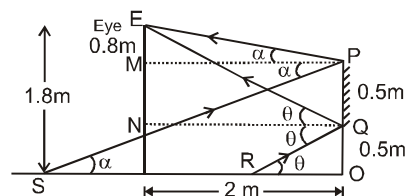

$$\text{So, } \frac{EM}{PO} = \frac{MP}{OS} \Rightarrow OS = 1 \times \frac{2}{0.8} \text{ m} = 2.5 \text{ m.}$$

Similarly, ΔENQ and ΔQOR are similar.

$$\text{So, } \frac{EN}{QO} = \frac{QN}{RO} \Rightarrow RO = \frac{0.5 \times 2}{(1.8 - 0.5)} \text{ m} = 0.77 \text{ m.}$$

Hence, length of wall visible in mirror.

$$= OS - OR = (2.5 - 0.77) \text{ m} = 1.73 \text{ m.}$$

58. -6

59. Let the object be placed at a distance x from the concave mirror as shown.

for concave mirror,
 $u = -x$ and $f = -F$

$$\frac{1}{v} + \frac{1}{u} = \frac{1}{f}$$

$$\frac{1}{v} = -\frac{1}{F} - \frac{1}{(-x)} = \frac{1}{x} - \frac{1}{F} \quad \therefore v = \frac{Fx}{(F-x)}$$

Also $m = \frac{-v}{u} = \frac{F}{(F-x)}$

For convex mirror, $u = -(1-x)$ and $f = F$

$$\therefore v = \frac{F(1-x)}{F+(1-x)} \Rightarrow m = -\frac{v}{u} = \frac{F}{(F+1-x)}$$

But size of the images formed are same

So, $\left| \frac{F}{(F-x)} \right| = \frac{F}{(F+1-x)}$

$$\Rightarrow \frac{-F}{(F-x)} = \frac{F}{F+1-x}$$

(for $F-x < 0$)

for $F-x > 0$ $\frac{F}{F-x} = \frac{F}{F+1-x}$

(which is not possible).

$$x = \frac{2F+1}{2} = \frac{2 \times 0.36 + 1}{2} \text{ m} = 0.86 \text{ m} = 86 \text{ cm}$$

60. Let the situation be as shown in figure with the object and image shown at A. For image formation by concave mirror,

$$u = -x$$

$$f = -f$$

$$\frac{1}{v} = \frac{1}{f} - \frac{1}{u} = -\frac{1}{f} + \frac{1}{x}$$

$$\Rightarrow v = \frac{fx}{f-x}$$

\therefore Distance of the image from the convex mirror

$$= 4f + \frac{fx}{f-x} = \frac{4f^2 - 3fx}{(f-x)}$$

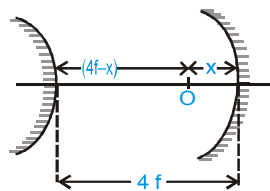
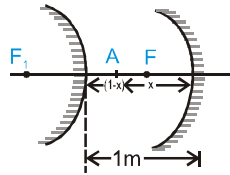

Now for image formation by convex mirror,

$$u = -\frac{(4f^2 - 3fx)}{(f-x)} \Rightarrow f = f$$

By the question,

$$v = -(4f-x) \therefore \frac{1}{v} = \frac{1}{f} - \frac{1}{u} \text{ gives,}$$

$$\frac{1}{-(4f-x)} = \frac{1}{f} + \frac{(f-x)}{(4f^2 - 3fx)}$$

on solving, we get, $x^2 - 6fx + 6f^2 = 0$

which gives, $x = (3 \pm \sqrt{3})f$ But $x < 4f$

Hence, $x = (3 - \sqrt{3})f$ Ans.

61. Let the situation be as shown in the adjoining figure.

So, for refraction on the water surface,

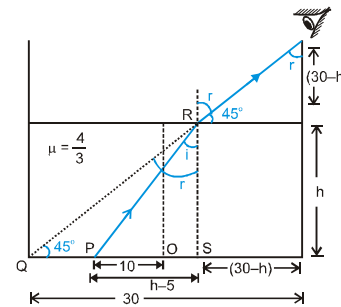

$$\frac{4}{3} \sin i = \sin r \Rightarrow 4 \sin i = 3 \sin r$$

But from the figure $r = 45^\circ$

So, $\tan i = \frac{3}{\sqrt{23}} = \frac{h-5}{h}$

from (i) and (ii) we get,

$$h = \frac{5\sqrt{23}}{(\sqrt{23} - 3)} \text{ cm} = 13.35 \text{ cm}$$

62. At a distance of 50 cm from the mirror & 2 cm from each other

63. (A) $\frac{169}{60} \text{ m} = 2.8 \text{ m}$

(B) $\frac{3}{5\sqrt{7}} \text{ m} = 22.6 \text{ cm}$

64. 9 cm/s

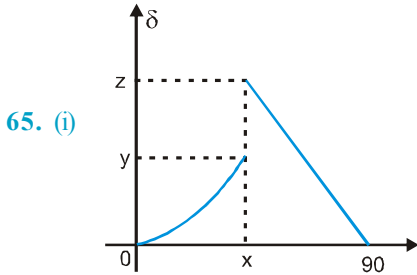

65. (i)

x is the minimum angle of incidence for total internal reflection.

$x = C$

for refraction

$$\text{if } i = C \Rightarrow r = \frac{\pi}{2} \Rightarrow \delta = (r - i) = \frac{\pi}{2} - C.$$

$$\Rightarrow y = \frac{\pi}{2} - C = 90^\circ - C$$

for total internal reflection,

$$\text{if } i = C \Rightarrow \delta = 180^\circ - 2i = 180 - 2C.$$

$$\Rightarrow z = \pi - 2C.$$

$$(ii) C = \sin^{-1} \left(\frac{4/3}{3/2} \right) = \sin^{-1} \left(\frac{8}{9} \right)$$

using graph required range is. y to z .

$$\Rightarrow \left[90^\circ - \sin^{-1} \left(\frac{8}{9} \right) \right] \text{ to } \left[180^\circ - 2 \sin^{-1} \left(\frac{8}{9} \right) \right]$$

66. Apparent shift in position of the object due to refraction

$$\text{through the slab} = d \left(1 - \frac{1}{\mu_{\text{rel}}} \right)$$

$$= 3 \left(1 - \frac{1}{\frac{3}{2}} \right) = 1 \text{ cm towards the mirror}$$

Now, for reflection from the mirror,

$$u = -30 \text{ cm.} \Rightarrow f = -\frac{R}{2} = -10 \text{ cm}$$

$$\therefore \frac{1}{v} = \frac{1}{f} - \frac{1}{u} \text{ gives } \frac{1}{v} = -\frac{1}{10} - \frac{1}{(-30)}$$

$$\therefore v = -15 \text{ cm}$$

Thus, image is formed 15 cm, right of the mirror but because of second refraction through the slab the image is shifted 1 cm away from the mirror. Hence final image is formed at a distance 16 cm away from mirror.

$$67. A = 60^\circ, \delta_{\text{min}} = 60^\circ \Rightarrow \mu = \frac{\sin \left(\frac{A + \delta_{\text{m}}}{2} \right)}{\sin A / 2}$$

$$\Rightarrow \mu = \frac{\sin 60^\circ}{\sin 30^\circ} = \frac{\sqrt{3}/2}{1/2} = \sqrt{3}$$

$$\mu = \frac{\sin 60^\circ}{\sin r_2} = \sqrt{3}$$

$$\Rightarrow \frac{\sqrt{3}}{2 \sin r_2} = \sqrt{3}$$

$$\sin r_2 = \frac{1}{2} \Rightarrow r_2 = 30^\circ$$

$$\Rightarrow r_1 = A - r_2 = 60^\circ - 30^\circ = 30^\circ$$

$$\therefore \frac{\sin 90^\circ}{\sin r_1} = \mu \Rightarrow \mu = \frac{1}{\sin 30^\circ} = 2 \neq \sqrt{3}$$

Hence, observations are not correct

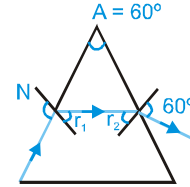

$$68. \frac{2}{\sqrt{3}} \leq \mu \leq \sqrt{2}$$

69. For image formation by lens :-

$$u = -40 \text{ cm}$$

$$f = +15 \text{ cm}$$

$$\frac{1}{v} = \frac{1}{f} + \frac{1}{u} = \frac{1}{15} - \frac{1}{40}$$

$$\therefore v = 24 \text{ cm}$$

So, image is formed at a distance 24 cm left of the lens.

For image formation by the mirror and the lens,

$$u = -10 \text{ cm} \Rightarrow f = -10 \text{ cm}$$

$$\Rightarrow \frac{1}{v} = \frac{1}{f} - \frac{1}{u} = -\frac{1}{10} + \frac{1}{10} = 0. \quad v = -\infty$$

for lens, $u = -\infty$ $f = 15 \text{ cm}$ $v = -15 \text{ cm}$

Thus, image is formed at a point 15 cm towards left from the mirror.

One at 15 cm and the other at 24 cm from the lens away from the mirror so distance between images 9 cm

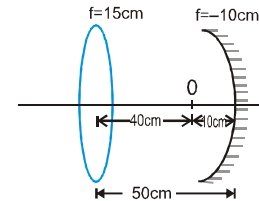

70. At the pole of reflecting surface of the sphere

71. Dispersive power = $\frac{\delta_V - \delta_R}{\delta_Y} = \frac{(\mu_V - \mu_R)}{(\mu_Y - 1)}$

= $\frac{(\mu_V - 1) - (\mu_R - 1)}{(\mu_Y - 1)}$

We know that, $\frac{1}{f} = (\mu - 1) \left(\frac{1}{R_1} - \frac{1}{R_2} \right) = (\mu - 1)K$

where $K = \frac{1}{R_1} - \frac{1}{R_2}$

So, $(\mu_V - 1)K = \frac{1}{98}$ (i)

$(\mu_R - 1)K = \frac{1}{100}$ (ii)

and $(\mu_Y - 1)K = \frac{1}{99}$ (iii)

∴ Dispersive power, $\omega = \frac{\frac{1}{98} - \frac{1}{100}}{\frac{1}{99}} = \frac{99}{4900}$

72. 90 cm below the bottom of the container.

73. (A) 3° (B) 0.015° (C) 3° (D) 0.225°

EXERCISE - 5

Part # I : AIEEE/JEE-MAIN

1. The objective of compound microscope is a lens and it forms real and enlarged image when an object is placed between its focus and lens.

2. $\frac{360^\circ}{\theta} - 1 = 3 \Rightarrow \theta = 90^\circ$

3. $i > c$ for ITR

∴ $45^\circ > \sin^{-1} \left(\frac{1}{n} \right) \Rightarrow n > \sqrt{2}$

4. To get real image of the size of the object, object should be placed at the centre of curvature of equivalent mirror.

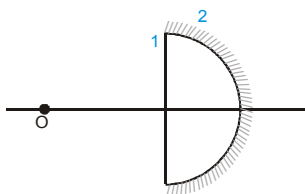

$\frac{1}{F} = \frac{1}{f_m} - \frac{2}{f_l} \Rightarrow f_m = -15 \text{ cm}$

and $\frac{1}{f_2} = \frac{1}{-15} - \frac{2}{60}$

$F_2 = -10 \text{ cm}$

Hence, object should be placed at 20cm from the combination

5. Angle of minimum deviation $D = (\mu - 1)A$

∴ $\mu_{\text{blue}} > \mu_{\text{red}}$

∴ $D_2 > D_1$

6. A travelling microscope moves horizontally on a main scale provided with a vernier scale, provided with the microscope

7. For a convex lens

$u = -ve \quad f = +ve$

If $v = \infty$, $u = f$ and if $u = -\infty$, $v = f$.

We have $v = +ve$ and $u = -ve$

and u and v are symmetrical. Hence graph is shown,

8. $\sin \theta = \frac{2}{\sqrt{3}} \sin r = \frac{2}{\sqrt{3}} \cos i$ (i)

and $\frac{2}{\sqrt{3}} \sin i = \sin 90^\circ$

⇒ $i = 60^\circ$ (ii)

From (i) and (ii)

$\sin \theta = \frac{1}{\sqrt{3}}$

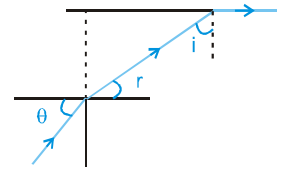

9. $v = u$ and $\frac{1}{v} + \frac{1}{u} = \frac{1}{f}$

$\frac{2}{v} = \frac{1}{f} \Rightarrow v = 2f, \quad u = 2f$

10. Mirror formula :

$\frac{1}{v} + \frac{1}{-280} = \frac{1}{20}$

$\frac{1}{v} + \frac{1}{20} = \frac{1}{280}$

$\frac{1}{v} + \frac{14+1}{280} \Rightarrow v = \frac{280}{15}$

$v_1 = - \left(\frac{v}{u} \right)^2 \cdot v_{\text{om}} \quad \therefore v_1 = - \left(\frac{280}{15 \times 280} \right)^2 \cdot 15$

∴ $v_1 = \frac{-15}{15 \times 15} \Rightarrow v_1 = -\frac{1}{15} \text{ m/s Ans.}$

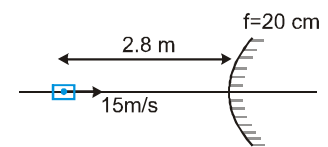

PHYSICS FOR JEE MAINS & ADVANCED

11. X-Y axis

$$\mu_1 \sin \theta_1 = \mu_2 \sin \theta_2$$

$$\cos \theta_1 = \frac{10}{\sqrt{(6\sqrt{3})^2 + (8\sqrt{3})^2 + 100}} = \frac{10}{\sqrt{400}} = \frac{10}{20}$$

$$\cos \theta_1 = \frac{1}{2} \Rightarrow \theta_1 = 60^\circ$$

$$\sqrt{2} \sin 60^\circ = \sqrt{3} \sin \theta_2$$

$$\sqrt{2} \times \frac{\sqrt{3}}{2} = \sqrt{3} \sin \theta_2$$

$$\sin \theta_2 = \frac{1}{\sqrt{2}} \Rightarrow \theta_2 = 45^\circ$$

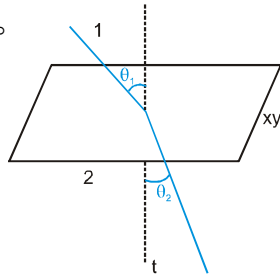

12. S_1 : When light reflects from denser med. (Glass) a phase drift of π is generated.

S_2 : Centre maxima or minima depends on thickness of the lens.

13. Apparent shift :

$$= h_1 \left(1 - \frac{1}{\mu_1}\right) + h_2 \left(1 - \frac{1}{\mu_2}\right)$$

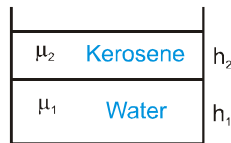

14. $\mu_R < \mu_B$

$$\frac{1}{f} = (\mu - 1) \left(\frac{1}{R_1} - \frac{1}{R_2} \right) \Rightarrow \frac{1}{f_B} > \frac{1}{f_R}$$

$$f_R > f_B.$$

15. $\frac{1}{f} = \frac{1}{12} + \frac{1}{240} = \frac{20+1}{240} \Rightarrow f = \frac{240}{21} \text{ m}$

$$\text{shift} = 1 \left(1 - \frac{2}{3}\right) = \frac{1}{3}$$

Now $v' = 12 - \frac{1}{3} = \frac{35}{3} \text{ cm}$

$$\therefore \frac{21}{240} = \frac{3}{35} - \frac{1}{u}$$

$$\frac{1}{u} = \frac{3}{35} - \frac{21}{240} = \frac{1}{5} \left(\frac{3}{7} - \frac{21}{48} \right)$$

$$\frac{5}{u} = \left| \frac{144 - 147}{48 \times 7} \right| \Rightarrow u = 560 \text{ cm} = 5.6 \text{ m}$$

16. 4

17. $y = 1.22 \frac{\lambda D}{d} = \frac{500 \times 10^{-9} \times 25 \times 10^{-2}}{2 \times 0.25 \times 10^{-2}}$

$$\Rightarrow y = 30 \mu\text{m}$$

18. Bends upwards

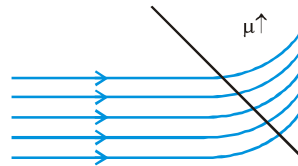

19. $r_2 < \theta_c$

$$r_2 < \sin^{-1}(1/\mu)$$

$$\sin r_2 < 1/\mu$$

$$\sin \theta = \mu \sin r_1$$

$$r_1 = \sin^{-1}(\sin \theta / \mu)$$

$$\sin(A - r_1) < 1/\mu$$

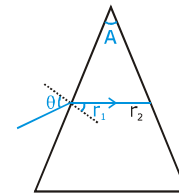

$$\sin \left(A - \left(\sin^{-1} \left(\frac{\sin \theta}{\mu} \right) \right) \right) < \frac{1}{\mu}$$

$$A - \sin^{-1} \left(\frac{\sin \theta}{\mu} \right) < \sin^{-1} \left(\frac{1}{\mu} \right)$$

$$A - \sin^{-1} \left(\frac{1}{\mu} \right) < \sin^{-1} \left(\frac{\sin \theta}{\mu} \right)$$

$$\left[\sin \left(A - \sin^{-1} \left(\frac{1}{\mu} \right) \right) \right] < \frac{\sin \theta}{\mu}$$

$$\sin^{-1} \left[\mu \left[\sin \left(A - \sin^{-1} \left(\frac{1}{\mu} \right) \right) \right] \right] < \theta$$

20 2

Part # II : IIT-JEE ADVANCED

1. (i) Applying Snell's law ($\mu \sin i = \text{constant}$) at 1 and 2 we have

$$\mu_1 \sin i_1 = \mu_2 \sin i_2$$

Here $\mu_1 = \mu_g$; and $\mu_2 = 1$ and $i_2 = 90^\circ$

$$i_1 = i$$

$$\mu_g \sin i = (1) (\sin 90^\circ)$$

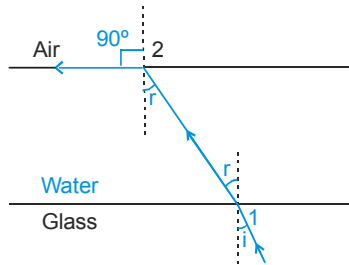

or $\mu_g = \frac{1}{\sin i}$

- (ii) Image formed by convex lens at I_1 will act as a virtual object for concave lens. For concave lens

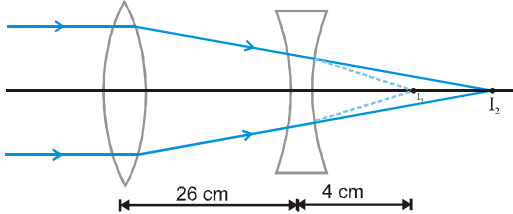

$$\frac{1}{v} - \frac{1}{u} = \frac{1}{f} \quad \text{or} \quad \frac{1}{v} - \frac{1}{4} = \frac{1}{-20} \quad \text{or} \quad v = 5 \text{ cm}$$

magnification for concave lens $m = \frac{v}{u} = \frac{5}{4} = 1.25$

As size of the image at I_1 is 2 cm. Therefore, size image at I_2 will be $2 \times 1.25 = 2.5$ cm.

2. For refraction at first surface,

$$\frac{\mu_2}{v_1} - \frac{\mu_1}{-\infty} = \frac{\mu_2 - \mu_1}{+R} \quad \dots\dots\dots(1)$$

For refraction at second surface,

$$\frac{\mu_3}{v_2} - \frac{\mu_2}{v_1} = \frac{\mu_3 - \mu_2}{+R} \quad \dots\dots\dots(2)$$

Adding Eqs. (1) and (2), we get

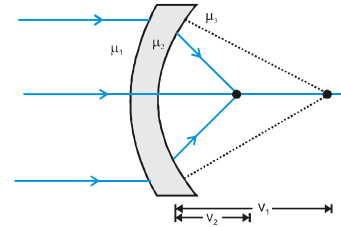

$$\frac{\mu_3}{v_2} = \frac{\mu_3 - \mu_1}{R} \quad \text{or} \quad v_2 = \frac{\mu_3 R}{\mu_3 - \mu_1}$$

Therefore, focal length of the given lens system is

$$\frac{\mu_3 R}{\mu_3 - \mu_1}$$

3. When the object is placed at the centre of the glass sphere, the rays from the object fall normally on the surface of the sphere and emerge undeviated.

Hence, the correct option is (B).

4. During minimum deviation the ray inside the prism is parallel to the base of the prism in case of an equilateral prism.

Hence, the correct option is (C)

5. Critical angle $\theta_c = \sin^{-1}\left(\frac{1}{\mu}\right)$

Wavelength increases in the sequence of VIBGYOR. According to Cauchy's formula refractive index (μ) decreases as the wavelength increases. Hence the refractive index will increase in the sequence of ROYGBIV. The critical angle θ_c will thus increase in the same order VIBGYOR. For green light the incidence angle is just equal to the critical angle. For yellow, orange and red the critical angle will be greater than the incidence angle. So these colours will emerge from the glass air interface.

Hence, the correct option is (A).

6. Applying Snell's law on face AB,

$$(1) \sin 45^\circ = (\sqrt{2}) \sin r$$

$$\therefore \sin r = \frac{1}{2} \quad \text{or} \quad r = 30^\circ$$

i.e., ray becomes parallel to AD inside the block.

Now applying,

$$\frac{\mu_2}{v} - \frac{\mu_1}{u} = \frac{\mu_2 - \mu_1}{R} \quad \text{on face CD,}$$

$$\frac{1.514}{OE} - \frac{\sqrt{2}}{\infty} = \frac{1.514 - \sqrt{2}}{0.4}$$

Solving this equation, we get $OE = 6.06$ m

7. Differentiating the lens formula $\frac{1}{v} - \frac{1}{u} = \frac{1}{f}$ with respect to time, we get

$$-\frac{1}{v^2} \cdot \frac{dv}{dt} + \frac{1}{u^2} \cdot \frac{du}{dt} = 0 \quad (\text{as } f = \text{constant})$$

$$\therefore \left(\frac{dv}{dt}\right) = \left(\frac{v^2}{u^2}\right) \frac{du}{dt} \quad \dots\dots(1)$$

Further, substituting proper values in lens formula,

$$\text{we have } \frac{1}{v} + \frac{1}{0.4} = \frac{1}{0.3} \quad (u = -0.4 \text{ m}, f = 0.3 \text{ m})$$

$$\text{or } v = 1.2 \text{ m}$$

Putting the values in Eq. (1)

Magnitude of rate of change of position of image = 0.09 m/s

$$\text{Lateral magnification, } m = \frac{v}{u}$$

$$\therefore \frac{dm}{dt} = \frac{u \cdot \frac{dv}{dt} - v \cdot \frac{du}{dt}}{u^2}$$

$$= \frac{(-0.4)(0.09) - (1.2)(0.01)}{(0.4)^2} = -0.3/s$$

\therefore Magnitude of rate of change of lateral magnification = 0.3/s

8. (A) At minimum deviation, $r_1 = r_2 = 30^\circ$

$$\therefore \text{From Snell's law } \mu = \frac{\sin i_1}{\sin r_1}$$

$$\text{or } \sqrt{3} = \frac{\sin i_1}{\sin 30^\circ}$$

$$\therefore \sin i_1 = \frac{\sqrt{3}}{2} \quad \text{or } i_1 = 60^\circ$$

(B) In the position shown below net deviation suffered by the ray of light should be minimum. Therefore, the second prism should be rotated by 60° (anticlockwise).

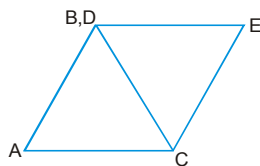

9. By mirror - lens combination formula

$$\frac{1}{F} = \frac{1}{f_m} - \frac{2}{f_L} \Rightarrow \frac{1}{F} = \frac{1}{\infty} - \frac{2}{15}$$

By mirror formula

$$\frac{1}{F} = \frac{1}{u} + \frac{1}{v} \Rightarrow -\frac{2}{15} = \frac{1}{-20} + \frac{1}{v}$$

$$\Rightarrow \frac{1}{v} = \frac{1}{20} - \frac{2}{15} = \frac{3-8}{60}$$

$v = -12 \text{ cm}$ negative means towards left

$$10. \frac{1}{f} = \frac{1}{v} - \frac{1}{u} \quad \dots\dots(1)$$

$$\frac{1}{f} = \frac{1}{10} - \frac{1}{-10}$$

$$f = +5$$

By differentiate eq. (1)

$$\Rightarrow \frac{-\Delta f}{f^2} = \frac{-\Delta v}{v^2} + \frac{\Delta u}{u^2} = \frac{1}{+v^2} \Delta v + \frac{1}{u^2} \Delta u$$

$$\Rightarrow + \frac{\Delta f}{5^2} = \frac{1 \times (0.1)}{+10^2} + \frac{1 \times (0.1)}{10^2}$$

$$\Delta f = \frac{0.2}{100} \times 25 = \frac{0.2}{4} = 0.05$$

So $f = 5 \pm 0.05$ **Ans.**

11. $r = f \tan \alpha$

Hence, $\pi r^2 \propto f^2$.

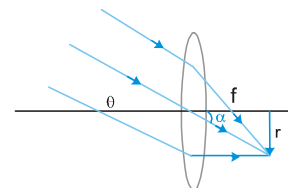

12. There will be partial reflection and refraction as shown in figure.

Angle between the reflected ray and the refracted ray = $180^\circ - (\theta + \phi)$

which is less than $180^\circ - 2\theta$ (because $\phi > \theta$)

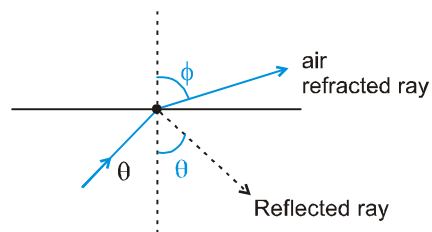

13. Laws of reflection are valid for all surfaces.

So statement (2) is incorrect.

14.

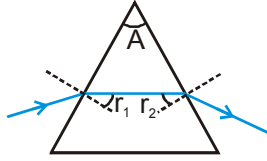

For minimum deviation $i = e$ and $r_1 = r_2 = A/2 = 30^\circ$ which is independent of nature of light. Both the lights are set for minimum deviation so angle of refraction will be 30° for both colours.

Ans. (A)

15. As the beam just suffers TIR at interface of region III and IV.

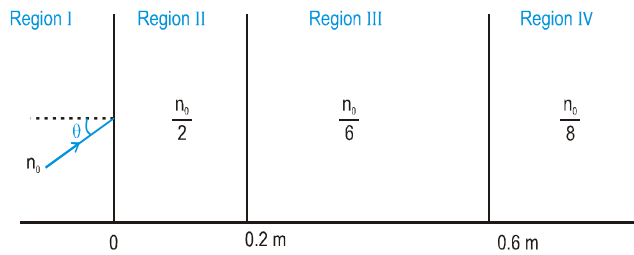

$$n_0 \sin \theta = \frac{n_0}{2} \sin \theta_1 = \frac{n_0}{6} \sin \theta_2 = \frac{n_0}{8} \sin 90^\circ$$

$$\sin \theta = \frac{1}{8} \Rightarrow \theta = \sin^{-1} \frac{1}{8} \text{ Ans. (B)}$$

16. (A) $f < 0$,

$$v = \frac{uf}{u-f} = \frac{f}{1-f/u} = \frac{u}{u/f-1} \text{ and } m = -\frac{v}{u}$$

values of v may be positive, negative or infinity, also it can have values less than or greater than u .

(A) $\rightarrow (p, q, r, s)$

(B) In this case f is positive.

So v will be positive and less than u . (B) $\rightarrow (q)$

$$(C) v = \frac{f}{1+f/u} = \frac{u}{u/f+1}$$

Here $u < 0$ $f > 0$

v may be positive, negative or infinity

v may be greater than or less than u

So (C) $\rightarrow (p, q, r, s)$

$$(D) \frac{1}{f} = (\mu - 1) \left(\frac{1}{R_1} - \frac{1}{R_2} \right)$$

for diagram $R_2 > R_1 \Rightarrow f$ is +ve

This is same as in case (C) for the nature of image.

So (D) $\rightarrow (p, q, r, s)$

$$17. x' = \frac{x}{n_{rel}}, v' = \frac{v}{n_{rel}} = \frac{\sqrt{2 \times 10 \times (20 - 12.8)}}{1} \times \frac{4}{3} = 16 \text{ m/s.}$$

$$18. \frac{1}{v} + \frac{1}{u} = \frac{1}{f} \text{ or } \frac{1}{-|v|} + \frac{1}{-|u|} = \frac{1}{-|f|}$$

$$\Rightarrow |v| = \frac{|u| |f|}{|u| - |f|}$$

$$\text{For } |u| = 42, |f| = 24; |v| = \frac{(42)(24)}{42 - 24} = 56 \text{ cm}$$

so (42, 56) is correct observation

For $|u| = 48$ or $|u| = 2f$ or $|v| = 2f$

so (48, 48) is correct observation

For $|u| = 66 \text{ cm}; |f| = 24 \text{ cm}$

$$|v| = \frac{(66)(24)}{66 - 24} \approx 36 \text{ cm}$$

which is not in the permissible limit so (66, 33), is incorrect recorded For $|u| = 78, |f| = 24 \text{ cm}$

$$|v| = \frac{(78)(24)}{78 - 24} \approx 32 \text{ cm}$$

which is also not in the permissible limit. so (78, 39), is incorrect recorded.

19. By refraction at face AB :

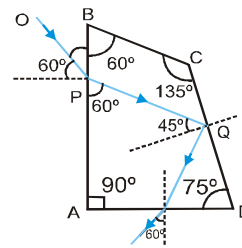

$$1. \sin 60^\circ = \sqrt{3} \cdot \sin r_1 \text{ So } r_1 = 30^\circ$$

This shows that the refracted ray is parallel to side BC of prism.

For side 'CD' angle of incidence will be 45° , which can be calculated

from quadrilateral PBCQ.

By refraction at face CD :

$$\sqrt{3} \sin 45^\circ = 1 \sin r_2$$

$$\text{So } \sin r_2 = \frac{\sqrt{3}}{\sqrt{2}}$$

which is impossible. So, there will be T.I.R. at face CD. Now, by geometry angle of incidence at AD will be 30° . So, angle of emergence will be 60° . Hence, angle between incident and emergent beams is 90°

PHYSICS FOR JEE MAINS & ADVANCED

20. When object distance is 25.

$$\frac{1}{v} - \frac{1}{u} = \frac{1}{f}$$

$$\frac{1}{v} - \frac{1}{(-25)} = \frac{1}{20} \Rightarrow v = 100 \text{ cm.}$$

$$m_{25} = \frac{v}{u} = \frac{100}{-25} = -4.$$

When object distance is 50.

$$\frac{1}{v} - \frac{1}{(-50)} = \frac{1}{20} \Rightarrow u = \frac{100}{3} \text{ cm}$$

$$m_{50} = \frac{\frac{100}{3}}{-50} = -\frac{2}{3} \Rightarrow \frac{m_{25}}{m_{50}} = \frac{-4}{-\frac{2}{3}} = 6.$$

Alternate :

$$\frac{m_{25}}{m_{50}} = \frac{\frac{f}{20-25}}{\frac{f}{20-50}} = \frac{-30}{-5} = 6$$

21. First image,

$$\frac{1}{v} - \frac{1}{u} = \frac{1}{f}$$

$$\frac{1}{v} - \frac{1}{-30} = \frac{1}{15}$$

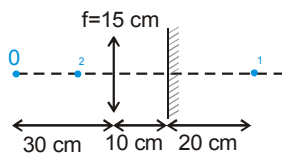

$v = 30$, image is formed 20 cm behind the mirror.

Second image, by plane mirror will be at 20 cm in front of plane mirror.

For third image, $\frac{1}{v} - \frac{1}{10} = \frac{1}{15}$

$$\frac{1}{v} = \frac{1}{10} + \frac{1}{15} = \frac{3+2}{30} = \frac{5}{30}$$

$v = 6 \text{ cm}$

Ans. Final image is real & formed at a distance of 16 cm from mirror.

22. $R = 20 \text{ m}$, $f = 10 \text{ m}$

For mirror,

$$\frac{1}{v} + \frac{1}{u} = \frac{1}{f} \Rightarrow \frac{1}{25/3} + \frac{1}{u_1} = \frac{1}{10}$$

$$\frac{1}{u_1} = \frac{1}{10} - \frac{3}{25} = -\frac{1}{50} \Rightarrow u_1 = -50 \text{ cm}$$

$$\& \frac{1}{50/7} + \frac{1}{u_2} = \frac{1}{10} \Rightarrow \frac{1}{u_2} = -\frac{1}{25}$$

$$\Rightarrow u_2 = -25 \text{ cm}$$

So, speed = $\left| \frac{\Delta u}{\Delta t} \right| = \frac{25}{30} \text{ m/sec.} = \frac{5}{6} \text{ m/sec.}$

& in km/hr = $\frac{5}{6} \times \frac{18}{5} = 3 \text{ km/hr.}$

23. $\tan C = \frac{R}{8}$ (i)

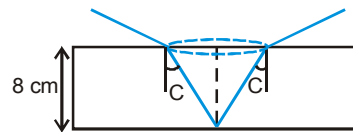

$$\frac{5}{3} \sin C = 1 \cdot \sin 90^\circ \Rightarrow \sin C = \frac{3}{5}$$

$$C = 37^\circ \Rightarrow \frac{3}{4} = \frac{R}{8} \Rightarrow R = 6 \text{ cm. Ans.}$$

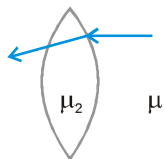

24. (A) μ_3

$$\mu_2 = \mu_3$$

As there is no deviation. As the light bends towards normal in denser medium $\mu_2 > \mu_1$

p - A & C

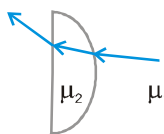

(B) μ_3

As light bends away from normal

$$\mu_2 < \mu_1 \& \mu_3 < \mu_2$$

q - B & D

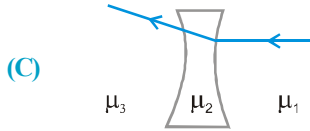

$\mu_2 = \mu_3$ (As no deviation)
 $\mu_2 > \mu_1$ (As light bends towards normal)
 r - C & A

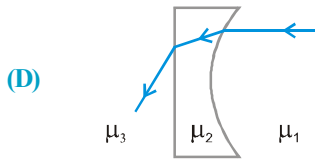

$\mu_2 < \mu_1$
 $\mu_3 < \mu_2$
 As light bends away from normal
 s - B, D

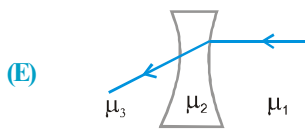

$\mu_2 = \mu_3$ As no deviation of light
 $\mu_2 < \mu_1$ As light bend away from normal
 t - C & B

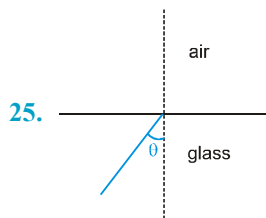

Initially most of part will be transmitted. When $\theta > i_c$, all the light rays will be total internal reflected.
 So transmitted intensity = 0
 So correct answer is (C)

26. $\frac{\mu_2}{v} - \frac{\mu_1}{u} = \frac{\mu_2 - \mu_1}{R}$

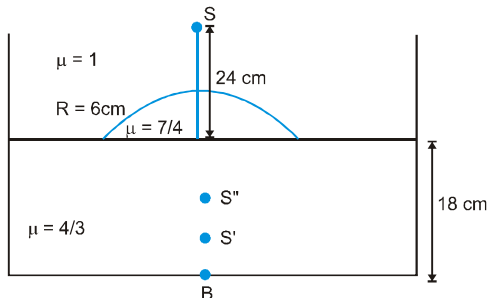

$$\frac{7}{4v} - \frac{1}{-24} = \frac{\frac{7}{4} - 1}{6}$$

$$\frac{7}{4v} = \frac{3}{24} - \frac{1}{24} = \frac{2}{24} = \frac{1}{12}$$

$$\frac{7 \times 12}{4} = v = 21 \text{ cm}$$

$$\frac{21}{OS''} = \frac{7/4}{4/3}$$

$$\frac{21}{OS''} = \frac{7}{4} \times \frac{3}{4}$$

$$OS'' = 16$$

$$\therefore BS'' = 2 \text{ cm}$$

27. $\frac{1}{f_1} = (\mu - 1) \left[\frac{1}{R_1} - \frac{1}{R_2} \right]$

$$\frac{1}{f_1} = (1.5 - 1) \left[\frac{1}{14} - \frac{1}{\infty} \right]$$

$$\frac{1}{f_1} = \frac{0.5}{14}$$

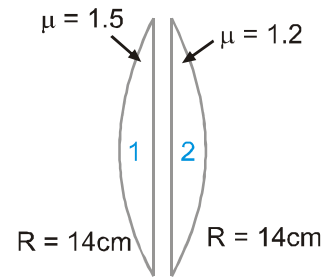

$$\frac{1}{f_2} = (1.2 - 1) \left[\frac{1}{\infty} - \frac{1}{-14} \right]$$

$$\frac{1}{f_2} = \frac{0.2}{14}$$

$$\frac{1}{f} = \frac{1}{f_1} + \frac{1}{f_2} = \frac{0.5}{14} + \frac{0.2}{14}$$

$$\frac{1}{f} = \frac{0.7}{14} \Rightarrow \frac{1}{v} = \frac{7}{140} - \frac{1}{40} = \frac{1}{20} - \frac{1}{40}$$

$$\frac{1}{v} = \frac{2-1}{40} \Rightarrow v = 40 \text{ cm}$$

PHYSICS FOR JEE MAINS & ADVANCED

28. $n = \frac{c}{v}$ for metamaterials

$$v = \frac{c}{|n|}$$

29. Meta material has a negative refractive index

$$\therefore \sin \theta_2 = \frac{n_1}{n_2} \sin \theta_1 \Rightarrow n_2 \text{ is negative } \therefore \theta_2 \text{ negative}$$

30. A, C

31. C

33. Image for mirror

$$\frac{1}{v} + \frac{1}{(-15)} = -\frac{1}{10}$$

$$\Rightarrow \frac{1}{v} = \frac{1}{15} - \frac{1}{10} = \frac{2-3}{30} = -\frac{1}{30}$$

$$v = -30 \text{ cm} \ \& \ m_1 = -\frac{v}{u} = -\frac{(-30)}{(-15)} = -2$$

Image from lens

$$\frac{1}{v} - \frac{1}{u} = \frac{1}{f}$$

$$\Rightarrow \frac{1}{v} + \frac{1}{20} = \frac{1}{10}$$

$$\Rightarrow \frac{1}{v} = \frac{1}{10} - \frac{1}{20}$$

$$\Rightarrow v = -20 \text{ cm}$$

$$m_2 = -1$$

$$|M_1| = |m_1 \times m_2| = 2$$

In air for lens

$$\frac{1}{f} = \left(\frac{1}{2}\right) \left(\frac{2}{R}\right) \Rightarrow R = 10 \text{ cm}$$

When dipped

$$\frac{1}{f'} = \left(\frac{3}{2} \times \frac{6}{7} - 1\right) \left[\frac{2}{10}\right] = \frac{2}{7} \times \frac{2}{10} = \frac{4}{70} = \frac{2}{35}$$

$$\frac{1}{v'} = \frac{2}{35} - \frac{1}{10} = \frac{8-7}{140} \Rightarrow m_2 = 7 \Rightarrow |M_2| = 14$$

$$|M_2|/|M_1| = 7$$

34.

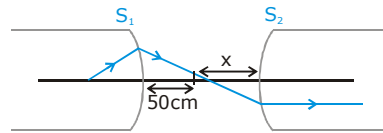

$$\frac{\mu_2}{v} - \frac{\mu_1}{u} = \frac{\mu_2 - \mu_1}{R}$$

$$\frac{1}{v} - \frac{1.5}{-50} = \frac{1 - 1.5}{-10}$$

$$\frac{1}{v} + \frac{15}{500} = \frac{5}{100}$$

$$\Rightarrow \frac{1}{v} = \frac{1}{20} - \frac{3}{100} = \frac{5-3}{100}$$

$$\frac{1}{v} = \frac{2}{100}$$

$$v = \frac{100}{2} = 50$$

now for S_2

$$\frac{\mu_2}{v} - \frac{\mu_1}{u} = \frac{\mu_2 - \mu_1}{R}$$

$$u = -x$$

$$v \rightarrow \infty$$

$$\frac{1.5}{\infty} - \frac{1}{x} = \frac{1.5 - 1}{10}$$

$$x = +20$$

$$d = 50 + 20 = 70 \text{ cm}$$

35. $\delta = i + \theta - 60^\circ$

$$1 \times \sin 60^\circ = n \times \sin r_1$$

$$r_1 = \sin^{-1} \left(\frac{\sqrt{3}}{2n} \right)$$

By snell's law

$$1 \times \sin \theta = n \sin \left(60^\circ - \sin^{-1} \left(\frac{\sqrt{3}}{2n} \right) \right)$$

$$\sin \theta = \left[\frac{\sqrt{3}}{2} \frac{\sqrt{4n^2 - 3}}{2} - \frac{1}{2} \sqrt{\frac{3}{2}} \right]$$

Differentiating w.r.t. n :

$$\cos\theta \, d\theta = \frac{\sqrt{3}}{2} \cdot \frac{8n}{2\sqrt{4n^2 - 3} \times 2} \, dn$$

$$\therefore \theta = 60^\circ, \quad n = \sqrt{3}$$

$$\frac{1}{2} \frac{d\theta}{dn} = \frac{\sqrt{3}}{2} \frac{8\sqrt{3}}{2\sqrt{4(\sqrt{3})^2 - 3} \times 2} \, dn$$

$$\frac{d\theta}{dn} = 2$$

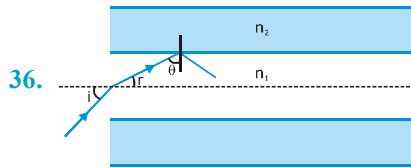

For TIR = $\theta \geq \theta_c = \sin^{-1}\left(\frac{n_2}{n_1}\right)$

$$\Rightarrow r = 90^\circ - \theta$$

$$\Rightarrow n(\sin i) = n_1 \sin r = n_1 \cos \theta$$

$$\Rightarrow n \sin i_m = n_1 \cos \theta_c$$

$$= n_1 \sqrt{1 - \frac{n_2^2}{n_1^2}} = \sqrt{n_1^2 - n_2^2}$$

$$NA = \sin i_m = \frac{1}{n} \sqrt{n_1^2 - n_2^2}$$

Now put values.

37. D

MOCK TEST

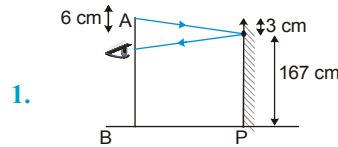

Figure in self explanatory.

2. $\frac{I}{O} = -\frac{V}{u}$

If O and I are on same sides of PA. $\frac{I}{O}$ will be positive which implies v and u will be of opposite signs.

Similarly if O and I are on opposite sides, $\frac{I}{O}$ will be -ve which implies v and u will have same sign.

If O is on PA, $I = \left(-\frac{V}{u}\right)(O) \Rightarrow I$ will also be on P.A.

3. $\vec{V}_1 m = \vec{V}_0 m$ (normal to plane mirror)

$$\Rightarrow \vec{v}_1 - \vec{v}_m = -(\vec{V}_0 - \vec{V}_m)$$

$$\vec{V}_1 - V \sin \theta = -(0 - V \sin \theta)$$

$$V_1 = 2V \sin \theta$$

4. As AB is common and $O_1 B = B I$
 $\Delta O_1 B A$ and $\Delta B A I$ are congruent
 By symmetry AI is perpendicular to $O_1 I$ to $O_2 I$
 and $\angle O_1 A B = \angle B A I$

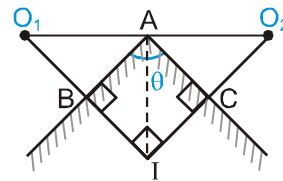

$\therefore \angle B A I = 45^\circ$
 and $\angle B A C = 90^\circ$

5. By snell's law :

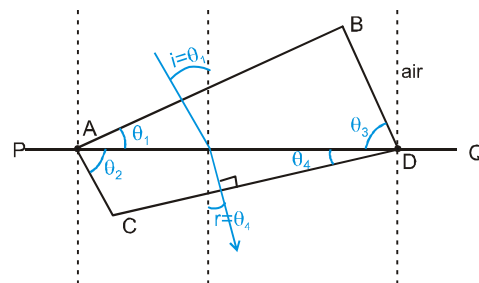

$$\frac{\sin i}{\sin r} = \frac{\mu_2}{\mu_1}$$

for $i = \theta_1, r = \theta_4$ and $\mu_1 = 1, \mu_2 = \frac{\sin \theta_1}{\sin \theta_4}$.

6. As we know that light travels in a path such as to reach from one point to another in shortest possible time.

Therefore, the man must travel along that path on which light would have travelled in moving from P to Q.

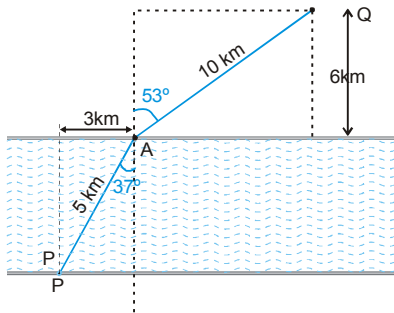

By Snell's law ;

$$\frac{\sin i}{\sin r} = \frac{\mu_2}{\mu_1} \Rightarrow \sin r = \frac{\mu_1}{\mu_2} \cdot \sin i$$

$$\sin r = \frac{3}{5} \cdot \frac{4}{3} = \frac{4}{5} \Rightarrow r = 53^\circ$$

$\therefore AQ = 10 \text{ Km}$.

From P to A :

$$t_1 = \frac{5}{3}$$

From A to Q :

$$t_2 = \frac{10}{4} = \frac{5}{2}$$

$$T = t_1 + t_2 = \frac{5}{3} + \frac{5}{2} = \frac{25}{6} \text{ hr.} = \left(\frac{24}{6} + \frac{1}{6} \right) \text{ hr}$$

$$= \left(4 \text{ hr} + \frac{1}{6} \text{ hr} \right) = 4 \text{ hr} + 10 \text{ minutes}$$

7. $\frac{x}{1} = \frac{x_{\text{rel}}}{\mu} \quad x_{\text{rel}} = \mu x$

$$\frac{d^2 x_{\text{rel}}}{dt^2} = \mu \frac{d^2 x}{dt^2} \Rightarrow a_{\text{rel}} = \mu g$$

8. $A = 90^\circ - \theta$
 $r_2 = A = 90^\circ - \theta > \theta_C$

$$\cos \theta > \sin \theta_C = \frac{6/5}{3/2} = \frac{4}{5}$$

(θ_C is critical angle)

$$\Rightarrow \theta < \cos^{-1} \frac{4}{5} = 37^\circ$$

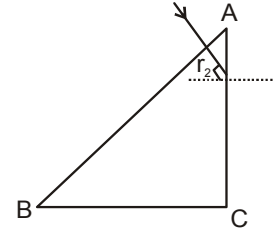

9. $r_2 < \theta_C ; A - r_1 < \theta_C ; r_1 > A - \theta_C$

$$\Rightarrow \sin r_1 > \sin(A - \theta_C) \Rightarrow \frac{\sin i}{\mu} > \sin(A - \theta_C)$$

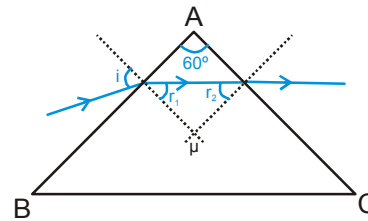

$$\Rightarrow \sin i > \mu (\sin A \cos \theta_C - \sin \theta_C \cos A)$$

$$= \sqrt{\frac{7}{3}} \left(\frac{\sqrt{3}}{2} \sqrt{1 - \frac{3}{7}} - \sqrt{\frac{3}{7}} \cdot \frac{1}{2} \right) = 1 - \frac{1}{2} = \frac{1}{2}$$

$$\Rightarrow \sin i > \frac{1}{2} \text{ or } i > 30^\circ$$

10. Given $i = 60^\circ, A = \delta = e$

$$\delta = i + e - A \Rightarrow \delta = i \quad (\because e = A) \text{ and } \delta = i = e$$

$$\mu = \frac{\sin \left(\frac{A + \delta_m}{2} \right)}{\sin \frac{A}{2}}$$

Here angle of deviation is minimum ($\because i = e$)

$$\mu = \frac{\sin \left(\frac{60^\circ + 60^\circ}{2} \right)}{\sin (60^\circ / 2)} = \sqrt{3} \text{ Ans.}$$

11. Using formula of spherical surface taking 'B' as object

$$\frac{\mu_2}{\infty} - \frac{\mu_1}{(-2R)} = \frac{\mu_2 - \mu_1}{-R} \quad (\text{R being the radius of the curved surface})$$

$$\Rightarrow \frac{\mu_1}{\mu_2} = 2$$

12. For spherical surface

$$\text{using } \frac{n_2}{v} - \frac{n_1}{u} = \frac{n_2 - n_1}{R}$$

$$\Rightarrow \frac{n}{2R} - \frac{1}{\infty} = \frac{n-1}{R}$$

$$\Rightarrow n = 2n - 2 \Rightarrow n = 2.$$

13. The image is erect hence, mirror must be between object & image. Virtual image of real object is diminished, hence mirror is convex.

14. Acceleration of block AB = $\frac{3mg}{3m+m} = \frac{3}{4}g$;

acceleration of block CD = $\frac{2mg}{2m+m} = \frac{2g}{3}$

Acceleration of image in mirror AB
= 2 acceleration of mirror

$$= 2 \cdot \left(\frac{-3g}{4} \right) = \frac{-3}{2}g$$

Acceleration of image in mirror CD = $2 \cdot \left(\frac{2g}{3} \right) = \frac{4g}{3}$

∴ Acceleration of the two image w.r.t. each other

$$= \frac{4g}{3} - \left(\frac{-3g}{2} \right) = \frac{17g}{6}$$

15. In the first case the distance travelled in the slab < distance travelled in the slab in the 2nd case.

16. Considering refraction at the curved surface,

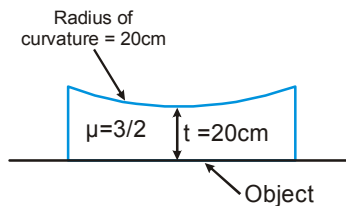

$$u = -21\sqrt{3} ; \mu_2 = 1 \qquad \mu_1 = 3/2 ; R = +20$$

applying $\frac{\mu_2}{v} - \frac{\mu_1}{u} = \frac{\mu_2 - \mu_1}{R}$

$$\Rightarrow \frac{1}{v} - \frac{3/2}{-20} = \frac{1-3/2}{20} \Rightarrow v = -10$$

i.e. 10 cm below the curved surface

or 10 cm above the actual position of flower.

17. $\left(\frac{n_A - 1}{1} \right) \frac{2}{R_A} = \left(\frac{n_B - 1}{1} \right) \frac{2}{R_B}$

or $\frac{0.63}{R_A} = \frac{n_B - 1}{R_B}$

or $n_B = 1.7$

18. At first position of lens, let the distance of lens from object and screen be x and y respectively.

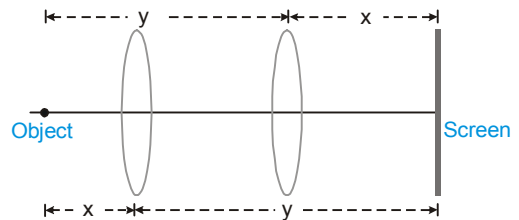

∴ $x + y = 100$ (1)

∴ At second position of lens the distance of lens from object and screen shall be y and x respectively.

∴ $y - x = 40$ (2)

solving equation (1) and (2) we get

$$y = 70 \text{ cm} = \frac{70}{100} \text{ m}$$

and $x = 30 \text{ cm} = \frac{30}{100} \text{ m}$

∴ The power of lens is

$$\frac{1}{f} = \frac{1}{y} + \frac{1}{x} = \frac{100}{70} + \left(\frac{100}{30} \right) = \frac{100}{21} \approx 5 \text{ diopters}$$

19. $\frac{1}{v} - \frac{1}{u} = \frac{1}{f}$

$$\frac{f}{v} - \frac{f}{u} = 1 \text{ or } \frac{1}{y} - \frac{1}{x} = 1$$

or $y = \frac{x}{x+1}$

Hence, a virtual erect image by a diverging lens is represented by

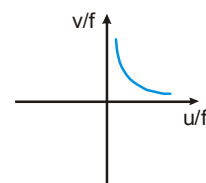

PHYSICS FOR JEE MAINS & ADVANCED

20. When mirror is rotated with angular speed ω , then the reflected ray rotates with angular speed $2\omega (= 36 \text{ rad/s})$

$$\begin{aligned} \text{speed of the spot} &= \left| \frac{dh}{dt} \right| = \left| \frac{d}{dt} (10 \cot \theta) \right| \\ &= \left| -10 \cos^2 \theta \frac{d\theta}{dt} \right| \end{aligned}$$

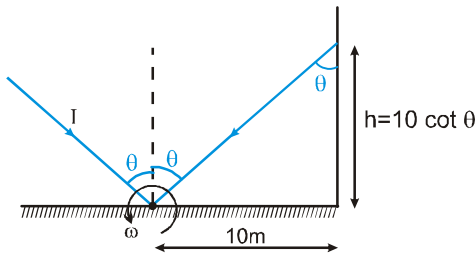

$$= \left| -\frac{10}{(0.6)^2} \times 36 \right| = 1000 \text{ m/s.}$$

21. Put $A = \delta_{\min}$ and $\mu = \sqrt{2}$

$$A = \delta_{\min} \quad \mu = \sqrt{2}$$

The relation $\mu = \frac{\sin\left(\frac{A + \delta_{\min}}{2}\right)}{\sin\left(\frac{A}{2}\right)}$ and solve for A

22. Let y-axis be vertically upwards and x-axis be horizontal.

$$\begin{aligned} V_{y(\text{app.})} &= \frac{V_{y(\text{real})}}{\left(\frac{1}{\mu}\right)} \\ V_{x(\text{app.})} &= V_{x(\text{real})} \\ \tan \phi &= \frac{V_{y(\text{app.})}}{V_{x(\text{app.})}} = \frac{4}{3} \tan \theta = \frac{4}{3} \times \frac{3}{4} = 1 \end{aligned}$$

23. Use refraction formulae separately that is for air and $\mu = 1.6$ and for air and $\mu = 2.0$ and find the positions of the two images.
24. Dispersion will not occur for a light of single wave length $\lambda = 4000 \text{ \AA}$.
25. This question should be solved by directly substituting the options
If $x = f, y = f$ then final image will be formed as shown.

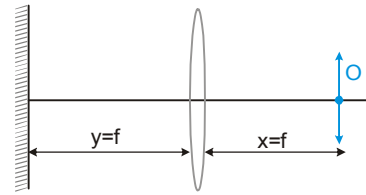

For option B and C the position of image will be different. When $x = 2f, y = 2f$, the lens makes image I' of object O on the surface of mirror as shown in the figure. Mirror shall make of image of I' over I' itself. Hence lens shall make image of I' at the position of O. (which is I)

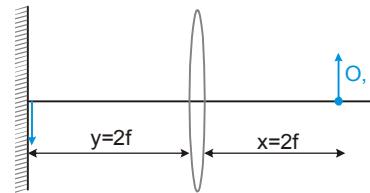

26. $v = -30, m = -\frac{v}{u} = -2$

$$\therefore A'B' = C'D' = 2 \times 1 = 2 \text{ mm}$$

$$\text{Now } \frac{B'C'}{BC} = \frac{A'D'}{AD} = \frac{v^2}{u^2} = 4$$

$$\Rightarrow B'C' = A'D' = 4 \text{ mm}$$

$$\therefore \text{length} = 2 + 2 + 4 + 4 = 12 \text{ mm}$$

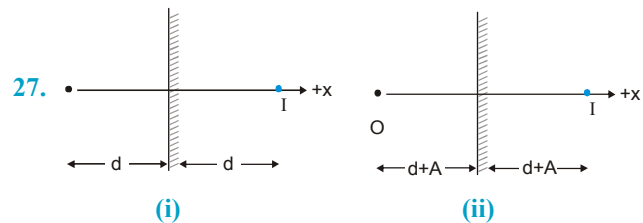

from figure (i) & (ii) it is clear that if the mirror moves distance 'A' then the image moves a distance '2A'.

28. for $M_1 : V = -60, m_1 = -2$
for $M_2 : u = +21, f = 10$

$$\therefore \frac{1}{V} + \frac{1}{20} = \frac{1}{10} \Rightarrow V = 20$$

$$\therefore M_2 = -\frac{20}{20} = -1$$

$$\therefore M = M_1 \times M_2 = +2$$

29. By mirror formula : $\frac{1}{v} + \frac{1}{-10} = \frac{1}{10}$

$\Rightarrow v = +5 \text{ cm} \therefore m = +\frac{1}{2}$

the image revolves in circle of radius $\frac{1}{2}$ cm. Image of a radius is erect \Rightarrow Image will revolve in the same direction as the particle. The image will complete one revolution in the same time 2s.

velocity of image $v = \omega r = \frac{2\pi}{2} \times \frac{1}{2} = \frac{\pi}{2} \text{ cm/s}$

= 1.57 cm/s

30. Cutting a lens in transverse direction doubles their focal length i.e. 2f.

Using the formula of equivalent focal length

$$\frac{1}{f} = \frac{1}{f_1} + \frac{1}{f_2} + \frac{1}{f_3} + \frac{1}{f_4}$$

We get equivalent focal length as $\frac{f}{2}$.

31. Draw an incident ray along the top side of rectangular strip, which happens to be parallel to the principal axis. After reflection this ray passes through focus. Hence image of all points (for e.g. O_1, O_2, O_3, \dots) on top side of the strip lie on this reflected ray (at I_1, I_2, I_3, \dots) in between focus and centre of curvature. Thus the image of this strip is a triangle as shown in figure

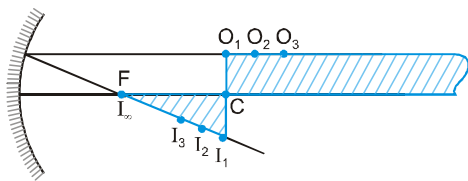

32. For refraction at glass-air interface, ray passing through point Q,

$$\frac{\sin r}{\sin 90} = \frac{1}{1.5}$$

$$\Rightarrow \sin r = \frac{1}{1.5}$$

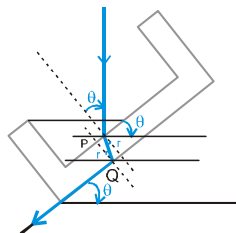

For refraction at water-glass interface, ray passing through point P,

$$\frac{\sin \theta}{\sin r} = \frac{1.5}{4/3} \Rightarrow \sin \theta = \frac{3}{4}$$

33. For convex mirror $|m| < 1$ for any real object

Now, $V_{\text{image}} = -m^2 V_{\text{object}}$

$\Rightarrow |V_{\text{image}}| < |V_{\text{object}}|$ always.

34. The image of a point closer to the focus will be farther. As the transverse magnification of B will be more than A, the image of AB will be inclined to the optical axis

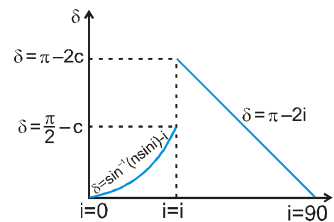

35.

36 $\delta = i + e - A$ (for minimum derivation $i = e$)

\therefore minimum deviation = $2i - A$

$60 = 2 \times 60 - A \Rightarrow \therefore A = 60^\circ$

$$n = \frac{\sin\left(\frac{A + \delta_m}{2}\right)}{\sin\left(\frac{A}{2}\right)} = \frac{\sin\left(\frac{60 + 60}{2}\right)}{\sin\left(\frac{60}{2}\right)} = \sqrt{3}$$

$\delta_1 = i_1 + e - A$

$65^\circ = i_1 + 70^\circ - 60^\circ$ or $i_1 = 55^\circ$

δ versus i curve is not parabolic

37. (A,C,D)

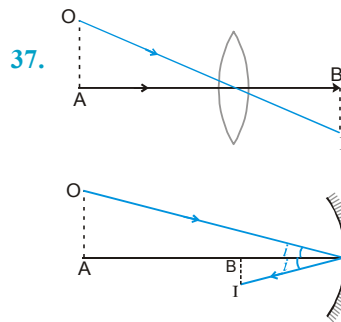

37.

Image is inverted \Rightarrow It should be real

38. The index of refraction for light at the red end of the visible spectrum is lesser than at the violet end. Hence statement -2 is false

39. Statement-2 is correct explanation of statement-1.

40. From symmetry the ray shall not suffer TIR at second interface, because the angle of incidence at first interface equals to angle of emergence at second interface. Hence statement 1 is false

PHYSICS FOR JEE MAINS & ADVANCED

41. If the mirror is shifted parallel to itself such that the velocity of the mirror is parallel to its surface, the image shall not shift. Hence statement 1 is false.

42. $\frac{1}{f} = \frac{1}{v} - \frac{1}{u}$

Here $v = 2.5$ (Distance of Retina as position of image is fixed)

$u = -x$

$\frac{1}{f} = \frac{1}{2.5} + \frac{1}{x}$

For f_{\min} : x is minimum $\frac{1}{f_{\min}} = \frac{1}{2.5} + \frac{1}{25}$

43. For f_{\max} : x is maximum $\frac{1}{f_{\max}} = \frac{1}{2.5} + \frac{1}{\infty}$

44. For near sighted man lens should make the image of the object within 100 cm range

For lens $u = -\infty$ $v = -100$

$\frac{1}{f_{\text{lens}}} = \frac{1}{-100} - \frac{1}{-\infty}$

45. From passage, (D) is correct.

46. From points (2) and (3) of passage : f and f' must be of opposite sign.

Also $\omega_c < \omega_d$ and $f_c < f_d$

which is satisfied only by (D).

47. $\frac{\omega_1}{f_1} + \frac{\omega_2}{f_2} = 0$

$\Rightarrow \frac{\omega_1}{\omega_2} = -\frac{f_1}{f_2} = \frac{1}{2}$ (1)

$\Rightarrow \frac{1}{F} = \frac{1}{f_1} + \frac{1}{f_2} = \frac{1}{40}$ (2)

After solving (1) & (2)

$f_1 = 20$ cm

$f_2 = -40$ cm.

48. $\frac{\mu_2}{v} = \frac{\mu_1}{u} + \left(\frac{\mu_2 - \mu_1}{R}\right)$

$(\mu_2 - \mu_1)$ is +ve and R is -ve if u is -ve, v will always be -ve

i.e. for real object image is always virtual.

49. (D)

50. (D)

48. to 50. Consider a object on left side of spherical surface separating two media.

If real object is in rarer media i.e., $n_1 < n_2$

Then $\frac{n_2}{v} = \frac{n_2 - n_1}{(-u)} + \frac{n_1}{(-R)} = -ve$

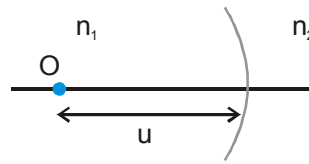

Hence image shall be virtual for a real object lying on concave side with rarer media. (1)

If real object is in denser media i.e., $n_1 > n_2$

$\frac{n_2}{v} = \frac{-(n_1 - n_2)}{(-u)} + \frac{n_1}{(-R)} = \frac{n_1 - n_2}{u} - \frac{n_1}{R}$

\therefore Image is real if $\frac{n_1 - n_2}{u} > \frac{n_1}{R}$

or $u < \frac{(n_1 - n_2)R}{n_1}$ (2)

and image is virtual if $u > \left(\frac{n_1 - n_2}{n_1}\right)R$ (3)

From statements 1, 2 and 3 we can easily conclude the answers.

51. $\vec{v}_A = \hat{i} + \vec{a}t = \hat{i} + (2\hat{i} + \hat{j})(2) = 5\hat{i} + 2\hat{j}$

$\vec{v}_{A'} = -5\hat{i} + 2\hat{j}$

$\vec{v}_{A',A} = \vec{v}_{A'} - \vec{v}_A = -10\hat{i}$

$\vec{v}_B = (-\hat{i} + 3\hat{j})$, $\vec{v}_{B'} = \hat{i} + 3\hat{j}$ So $\vec{v}_{B',B} = 2\hat{i}$

For particle C

$\frac{dv_y}{dt} = 2t \Rightarrow v_y - 6 = t^2 \Rightarrow v_y = 6 + 4 = 10$

$\vec{v}_C = 5\hat{i} + 10\hat{j}$, $\vec{v}_{C'} = -5\hat{i} + 10\hat{j}$

So $\vec{v}_{C',C} = -10\hat{i}$

$\vec{v}_D = 3\hat{i} - \hat{j}$, $\vec{v}_{D'} = -3\hat{i} - \hat{j}$, $\vec{v}_{D',D} = -6\hat{i}$

52. Initially the image is formed at infinity.

(A) As μ is increased the focal length decreases. Hence the object is at a distance larger than focal length. Therefore final image is real. Also final image becomes smaller in size in comparison to size of image before the change was made.

- (B) If the radius of curvature is doubled, the focal length decreases. Hence the object is at a distance lesser than focal length. Therefore final image is virtual. Also final image becomes smaller in size in comparison to size of image before the change was made.
- (C) Due to insertion of slab the effective object for lens shifts right wards. Hence final image is virtual. Also final image becomes smaller in size in comparison to size of image before the change was made.
- (D) The object comes to centre of curvature of right spherical surface as a result. Hence the final image is virtual. Also final image becomes smaller in size in comparison to size of image before the change was made.

53. Image by convex mirror is always virtual, erect and diminished.

In case of concave mirror, see using position of object.

54. By snell law $n = \frac{\sin i}{\sin r}$

Since for 1st case angular incidence is same for all ray. So r will be less for red.

55. (A) For plane incident wave fronts a divergent refracted beam can be formed only by diverging action and convergent reflected beam can be formed by converging action. Hence (A) p, r

(B) For plane incident wave fronts a convergent refracted beam can be formed only by converging action and divergent reflected beam can be formed by diverging action. Hence (B) q, s

(C) For a incident divergent beam a parallel reflected or refracted beam can be formed only by converging action. Hence (C) q, r

(D) For a incident convergent beam a parallel reflected or refracted beam can be formed only by diverging action. Hence (D) q, r

56. For a spherical mirror, line joining object and its image crosses principal axis at centre of curvature. The line joining object and image inverted about principal axis cuts the principal axis at the pole. Then from figure below.

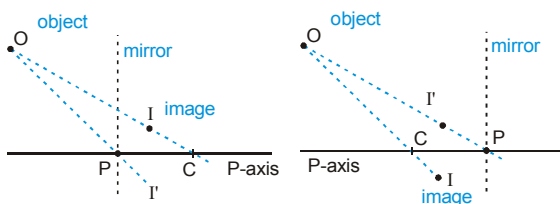

We can conclude

- (A) If object and image are on same side of principal axis, they are on opposite side of mirror.
- (B) If object and image are on opposite side of principal axis, they are on same side of mirror.

For a lens, the line joining object and image cuts the principal axis at optical centre.

Then from figures below.

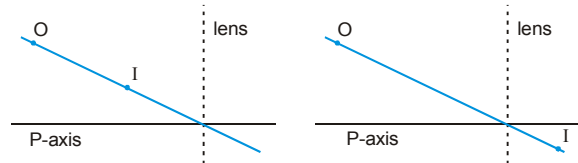

We can conclude

- (C) If object and image are on same side of principal axis, they are also on same side of lens.
- (D) If object and image are on opposite side of principal axis. They are also on opposite side of lens.

57. For $m_1, u = -10, f = -15, h = 2$.

Using mirror formula

$$\frac{1}{v} + \frac{1}{u} = \frac{1}{f}$$

$$\Rightarrow \frac{1}{v} + \frac{1}{-10} = \frac{1}{-15}$$

$$\Rightarrow \frac{1}{v} = \frac{1}{10} - \frac{1}{15} = \frac{3-2}{30}$$

$$= v = 30 \text{ cm}$$

$$\& \frac{h_2}{h_1} = -\frac{v}{u}$$

$$\Rightarrow h_2 = 6 \text{ cm}$$

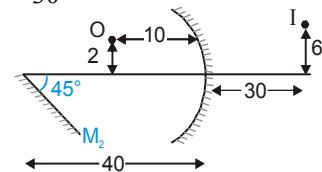
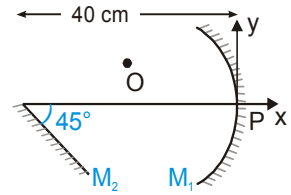

The image formed by the plane mirror is at 70 below the principal axis & $70 + 6 - 30 = 46$ of the concave mirror.

∴ coordinates of I2 w.r.t. P = (-46, -70)

5 By snell's law.

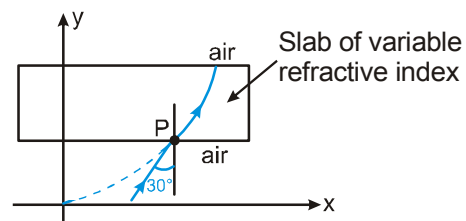

PHYSICS FOR JEE MAINS & ADVANCED

$1 \times \sin 30^\circ = \dots = n \sin i$
 where n is R.I. at y and i is angle of incidence at y .

$$\tan(90 - i) = \frac{dy}{dx} = 8x = 4\sqrt{y}$$

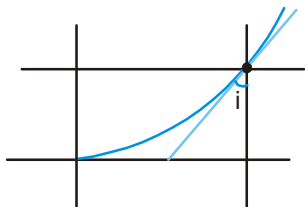

$$\cot i = 4\sqrt{y} = 4\sqrt{\frac{1}{2}} = 2\sqrt{2}$$

$$\Rightarrow \sin i = \frac{1}{3}$$

$$\therefore n = \frac{\sin 30^\circ}{\sin i} = \frac{1/2}{1/3} = 1.5$$

59.

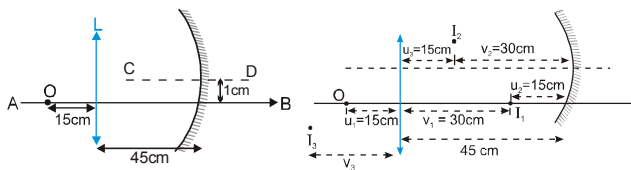

I_1 is the image of object O formed by the lens.

$$\frac{1}{v_1} - \frac{1}{u_1} = \frac{1}{f} \quad u_1 = -15 \quad f_1 = 10$$

Solving we get

$$v_1 = 30 \text{ cm}$$

I_1 acts as source for mirror

$$\therefore u_2 = -(45 - v_1) = -15 \text{ cm}$$

I_2 is the image formed by the mirror

$$\therefore \frac{1}{v_2} = \frac{1}{f_m} - \frac{1}{u_2} = -\frac{1}{10} - \frac{1}{15} \quad \therefore v_2 = -30 \text{ cm}$$

The height of I_2 above principal axis of lens is

$$= \frac{v_2}{u_2} \times 1 + 1 = 3 \text{ cm}$$

I_2 acts a source for lens

$$\therefore u_3 = -(45 - v_2) = -15 \text{ cm}$$

Hence the lens forms an image I_3 at a distance $v_3 = 30 \text{ cm}$ to the left of lens and the image of

$$I_3, \frac{v_3}{u_3} \times 3 = 6 \text{ cm below the principal axis of lens.}$$

The height of I_2 above principal axis of lens is

$$= \frac{v_2}{u_2} \times 1 + 1 = 3 \text{ cm}$$

$$\therefore \text{required distance} = \sqrt{30^2 + 6^2} = 6\sqrt{26} \text{ cm}$$

60. At $t = 0.2 \text{ sec}$, velocity of lens

$$V_\ell = gt = 2 \text{ m/s (downwards)}$$

\therefore for lens the fish appears to approach with a speed

$$\text{of } 2 + \left(1 \times \frac{3}{4}\right) = \frac{11}{4} \text{ m/s}$$

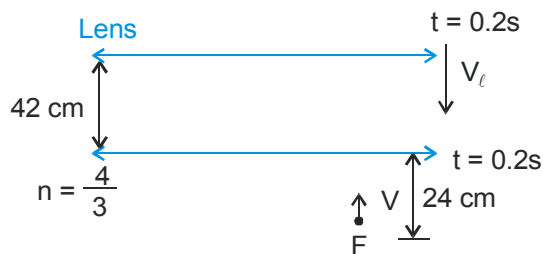

at a distance of $42 + \frac{24}{\left(\frac{4}{3}\right)} = 60 \text{ cm.}$

$$\therefore \text{image of fish from lens, } V = \frac{-60 \times 90}{-60 + 90} = -180 \text{ cm.}$$

\therefore Velocity of image w.r.t. lens

$$V_i = \left(\frac{v^2}{u^2}\right) \frac{du}{dt} = \left(\frac{-180}{-60}\right)^2 \times \frac{11}{4} = \frac{99}{4} \text{ m/s}$$

velocity of image w.r.t. observer

$$= V_i - 2 = \frac{99}{4} - 2 = \frac{91}{4} \text{ m/s} = 22.75 \text{ cm/s (upwards)}$$