

Alternating Current

Alternating Current

An electric current whose magnitude and direction changes continuously (periodically) with time is called an alternating current.

The instantaneous value of alternating current at any instant of time t is given by

$$I = I_0 \sin \omega t$$

where, I_0 = peak value of alternating current.

The variation of alternating current with time is shown in graph given below

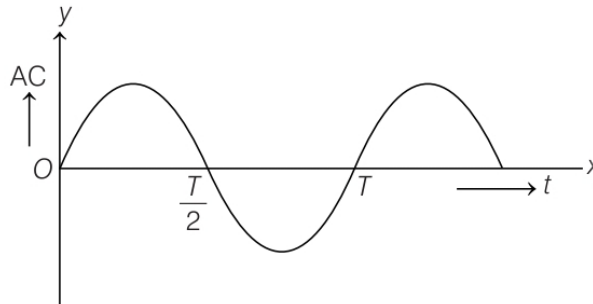

Mean Value and Root-Mean-Square Value of Alternating Current

- (i) **Mean Value** The mean value of alternating current over half-a cycle is a finite quantity and infact, it is this quantity which is defined as the mean value of alternating current.

It is given by

$$I_{\text{mean}} = \frac{1}{T/2} \int_0^{\pi/2} I dt$$

Mean or average value of alternating current for first half cycle

$$I_m = \frac{2I_0}{\pi} = 0.637 I_0$$

Mean or average value of alternating current for next half cycle

$$I'_m = -\frac{2I_0}{\pi} = -0.637 I_0$$

Mean or average value of alternating current for one complete cycle = 0.

In the same way, mean value of alternating voltage,

$$V_m = 0.637 V_0$$

- (iii) **Root-Mean-Square Value** The root-mean-square value of an alternating current is defined as the square root of the average of I^2 during a complete cycle.

The average value of I^2 over a complete cycle is given by

$$I^2 = \frac{1}{T} \int_0^T I^2 dt$$

Root-mean-square value of alternating current

$$I_{\text{rms}} = \frac{I_0}{\sqrt{2}} = 0.707 I_0$$

In the same way, root-mean-square value of alternating voltage

$$V_{\text{rms}} = \frac{V_0}{\sqrt{2}} = 0.707 V_0$$

Note Form factor is defined as the ratio of rms value of AC to its average value during half-cycle.

However, peak factor is the ratio of peak value to the rms value.

Reactance

The opposition offered by an inductor or by a capacitor in the path of flow of alternating current is called reactance.

Reactance is of two types

- (i) **Inductive Reactance** (X_L) Inductive reactance is the resistance offered by an inductor.

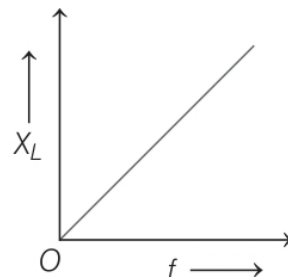

$$\text{Inductive reactance } (X_L) = L\omega = L2\pi f = \frac{L2\pi}{T}$$

$$X_L \propto f$$

For direct current, $X_L = 0$ ($\because f = 0$)

Its unit is ohm.

(ii) **Capacitive Reactance** (X_C) Capacitive reactance is the resistance offered by a capacitor.

Capacitive reactance,

$$X_C = \frac{1}{C\omega} = \frac{1}{C2\pi f} = \frac{T}{C2\pi}$$

$$X_C \propto \frac{1}{f}$$

For direct current, $X_C = \infty$ ($\because f = 0$)

Its unit is ohm.

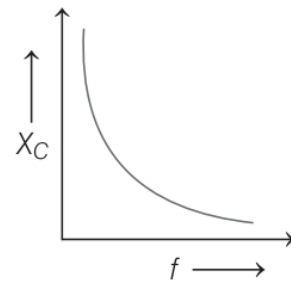

Impedance

The opposition offered by an AC circuit containing more than one out of three components L , C and R is called impedance (Z) of the circuit.

Impedance of an AC circuit, $Z = \sqrt{R^2 + (X_L - X_C)^2}$

Its SI unit is ohm.

Power in an AC Circuit

The power is defined as the rate at which work is being done in the circuit. The average power in an AC circuit,

$$\begin{aligned} P_{av} &= V_{rms} I_{rms} \cos \theta \\ &= \frac{V}{\sqrt{2}} \frac{I}{\sqrt{2}} \cos \theta = \frac{VI}{2} \cos \theta \end{aligned}$$

where, $\cos \theta = \frac{\text{Resistance}(R)}{\text{Impedance}(Z)}$ is called the power factor of AC circuit.

Current and Potential Relations for Different AC Circuits

Here, we will discuss current and potential relations for different AC circuits.

(i) **Pure Resistive Circuit (R Circuit)**

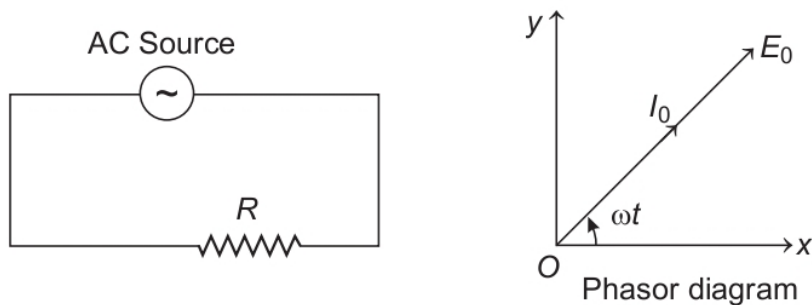

- (a) Alternating emf, $E = E_0 \sin \omega t$
- (b) Alternating current, $I = I_0 \sin \omega t$
- (c) Alternating emf and alternating current both are in the same phase.
- (d) Average power decay, $(\bar{P}) = E_V \cdot I_V$
- (e) Power factor, $\cos \theta = 1$

(ii) **Pure Inductive Circuit (L Circuit)**

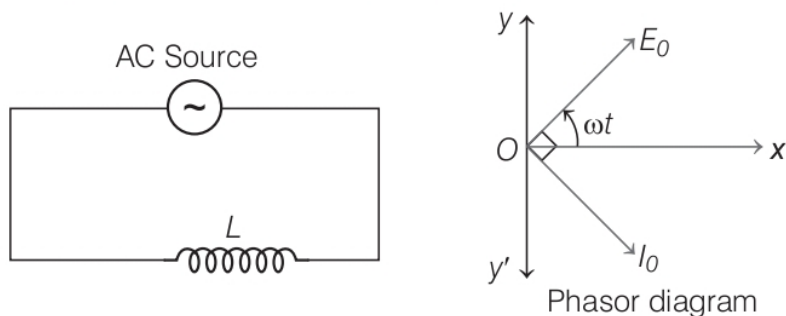

- (a) Alternating emf, $E = E_0 \sin \omega t$
- (b) Alternating current, $I = I_0 \sin (\omega t - \pi/2)$
- (c) Alternating current lags behind alternating emf by $\frac{\pi}{2}$.
- (d) Inductive reactance, $X_L = L\omega = L2\pi f$
- (e) Average power decay, $(\bar{P}) = 0$
- (f) Power factor, $\cos \theta = \cos 90^\circ = 0$

(iii) **Pure Capacitive Circuit**

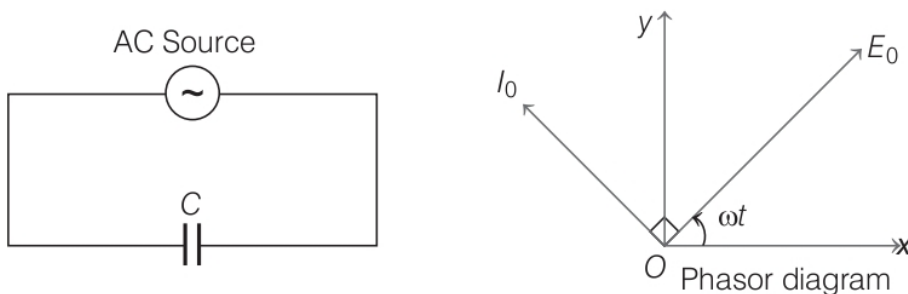

- (a) Alternating emf, $E = E_0 \sin \omega t$
- (b) Alternating current, $I = I_0 \sin (\omega t + \pi/2)$
- (c) Alternating current leads the alternating emf by $\frac{\pi}{2}$.
- (d) Capacitive reactance, $X_C = C\omega = C2\pi f$
- (e) Average power decay, $(\bar{P}) = 0$
- (f) Power factor, $\cos \theta = \cos 90^\circ = 0$

(iv) **R-C Circuit**

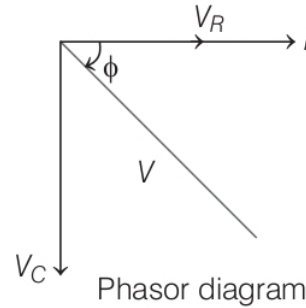
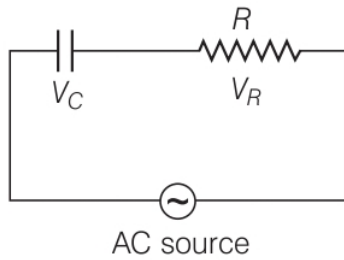

- (a) Alternating emf, $E = E_0 \sin \omega t$
- (b) Alternating current, $I = I_0 \sin (\omega t + \phi)$

(c) Impedance, $Z = \sqrt{R^2 + \left(\frac{1}{\omega C}\right)^2}$ and $\tan \phi = \frac{1}{\omega C R}$

- (d) Current leads the voltage by ϕ , where $V^2 = V_R^2 + V_C^2$

(v) **L-C Circuit**

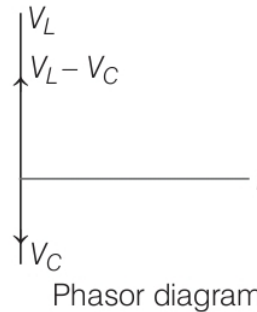
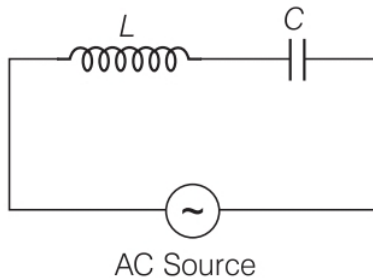

- (a) Alternating emf, $E = E_0 \sin \omega t$,
 - (b) Alternating current, $I = I_0 \sin (\omega t - \phi)$
 - (c) Impedance, $Z = X_L - X_C$ and $\tan \phi = \frac{X_L - X_C}{0}$
- For $X_L > X_C$, $\phi = \frac{\pi}{2}$ and for $X_L < X_C$, $\phi = -\frac{\pi}{2}$.
 - If $X_L = X_C$ at $\omega = \frac{1}{\sqrt{LC}}$, $Z = 0$.

(vi) **L-C-R Circuit**

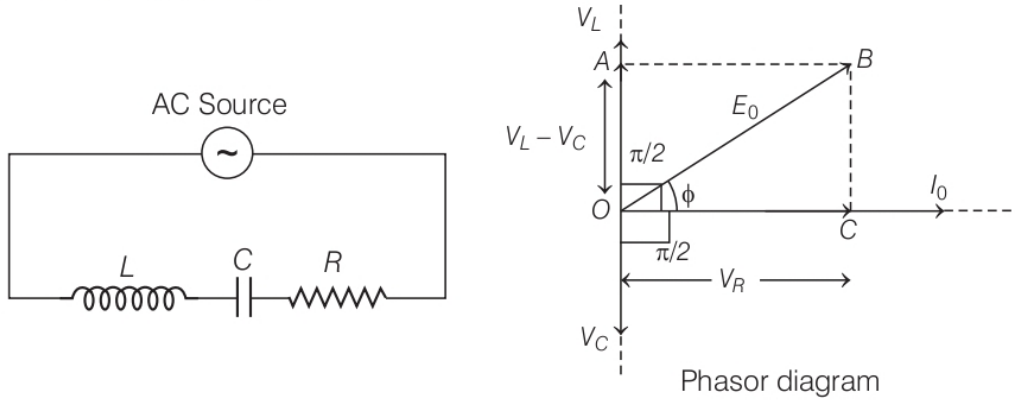

- (a) Alternating emf, $E = E_0 \sin \omega t$
- (b) Alternating current, $I = I_0 \sin (\omega t \pm \phi)$
- (c) Alternating current lags leads behind alternating emf by ϕ .
- (d) Resultant voltage, $V = \sqrt{V_R^2 + (V_L - V_C)^2}$
- (e) Impedance, $Z = \sqrt{R^2 + (X_L - X_C)^2}$
- (f) Power factor, $\cos \theta = \frac{R}{Z} = \frac{R}{\sqrt{R^2 + (X_L - X_C)^2}}$
- (g) Average power decay, $(\bar{P}) = E_V I_V \cos \theta$

Resonance in AC Circuit

The condition in which current is maximum or impedance is minimum or *vice-versa* in an AC circuit is called resonance.

(i) **Series Resonance Circuit**

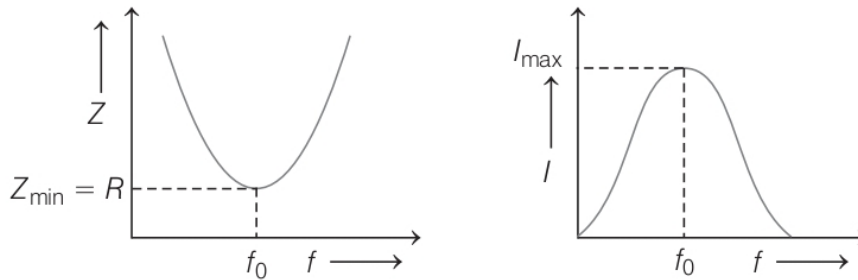

In this circuit components L , C and R are connected in series.

At resonance, $X_L = X_C$

Resonance frequency, $f = \frac{1}{2\pi\sqrt{LC}}$

At resonance impedance is minimum and equal to the resistance, *i.e.* $Z = R$.

Also, maximum current flows through the circuit.

Q -factor or sharpness at resonance

$$Q = \frac{1}{R} \sqrt{\frac{L}{C}}$$

A series resonance circuit is also known as acceptance circuit.

(ii) Parallel Resonance Circuit

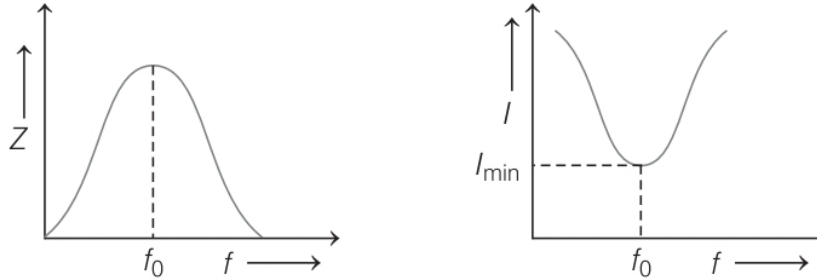

In this circuit, L and C are connected in parallel with each other.

At resonance, $X_L = X_C$

Impedance (Z) of the circuit is maximum.

Current in the circuit is minimum.

Wattless Current

The current which consumes no power for its maintenance in the circuit is called wattless current.

So, for an AC circuit if resistance is zero, its power factor will be zero. Although the current flows in the circuit, yet the average power remains zero. Such a circuit is called wattless circuit.

L-C Oscillations

When a charged capacitor is allowed to discharge through a non-resistive inductor, electrical oscillations of constant amplitude and frequency are produced these oscillations are called L - C oscillations. The equation of L - C oscillations is given by

$$\frac{d^2q}{dt^2} + \frac{1}{LC}q = 0$$

and the charge oscillates with a frequency

$$\nu = \frac{\omega}{2\pi} = \frac{1}{2\pi\sqrt{LC}}$$

Choke Coil

Choke coil is a device having high inductance and negligible resistance. It is used in AC circuits for the purpose of adjusting current to any required value in such a way that power loss in a circuit can be minimised. It is used in fluorescent tubes.

It is based on the principle of wattless current.

Transient Current

An electric current which vary for a small finite time, while growing from zero to maximum or decaying from maximum to zero is called a transient current.

Growth and Decay of Current in an Inductor

Growth of current in an inductor at any instant of time t is given by

$$I = I_0(1 - e^{-Rt/L})$$

where, I_0 = maximum current, L = self-inductance of the inductor and R = resistance of the circuit.

Here $\frac{R}{L} = \tau$ is called time constant of a L - R circuit.

Time constant of a L - R circuit is the time in which current in the circuit grows to 63.2% of the maximum value of current.

Decay of current in an inductor at any time t is given by

$$I = I_0 e^{-Rt/L}$$

Time constant of a L - R circuit is the time in which current decays to 36.8% of the maximum value of current.

Charging and Discharging of a Capacitor

The instantaneous charge on a capacitor on charging at any instant of time t is given by

$$q = q_0 [1 - e^{-t/RC}]$$

where $RC = \tau$, is called time constant of a R - C circuit.

The instantaneous charge on a capacitor in discharging at any instant of time t is given by $q = q_0 e^{-t/RC}$.

Time constant of a R - C circuit is the time in which charge in the capacitor grows to 63.8% or decay to 36.8% of the maximum charge on capacitor.

AC Generator or Dynamo

It is a device which converts mechanical energy into alternating current energy. Its working is based on electromagnetic induction.

The induced emf produced by the AC generator is given by

$$e = NBA\omega \sin \omega t = e_0 \sin \omega t$$

There are four main parts of an AC generator

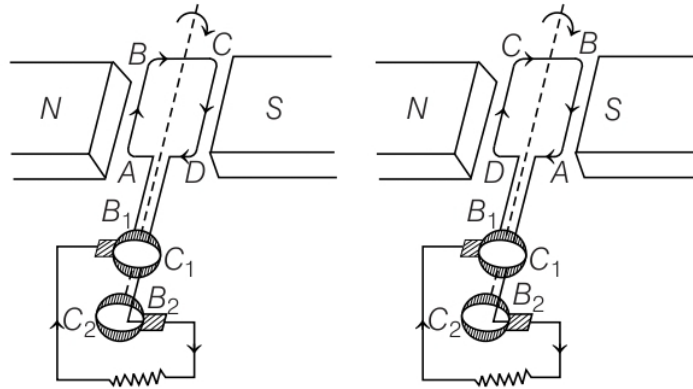

Working of AC dynamo

- (i) **Armature** It is rectangular coil of insulated copper wire having a large number of turns.
- (ii) **Field Magnets** These are two pole pieces of a strong electromagnet.
- (iii) **Slip Rings** These are two hollow metallic rings.
- (iv) **Brushes** These are two flexible metals or carbon rods, which remains slightly in contact with slip rings.

DC Motor

It is a device which converts electrical energy into mechanical energy. Its working is based on the fact that when a current carrying coil is placed in uniform magnetic field a torque acts on it.

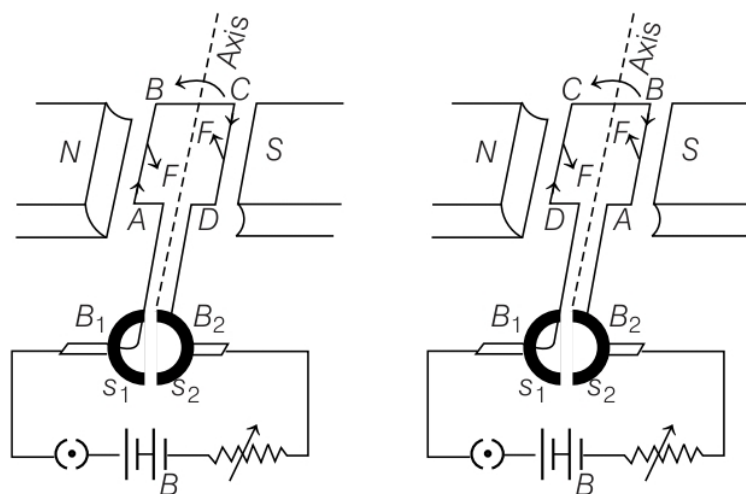

Torque acting on a current carrying coil placed in uniform magnetic field

$$\tau = NBIA \sin \theta$$

When armature coil rotates a back emf is produced in the coil.

Efficiency of a motor,
$$\eta = \frac{\text{Back emf}}{\text{Applied emf}} = \frac{E}{V}$$

Transformer

It is a device which can change a low voltage of high current into a high voltage of low current and *vice-versa*.

Its working is based on mutual induction.

There are two types of transformers

- (i) **Step-up Transformers** It converts a low voltage of high current into a high voltage of low current.

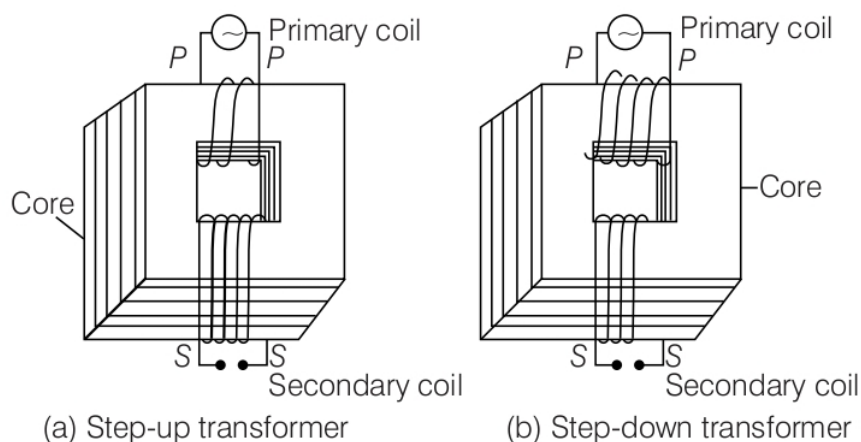

In this transformer,

$$N_S > N_P, E_S > E_P$$

and

$$I_P > I_S$$

- (ii) **Step-down Transformer** It converts a high voltage of low current into a low voltage of high current.

In this transformer,

$$N_P > N_S, E_P > E_S \text{ and } I_P < I_S$$

Transformation Ratio

Transformation ratio,
$$K = \frac{N_S}{N_P} = \frac{E_S}{E_P} = \frac{I_P}{I_S}$$

For step-up transformer, $K > 1$

For step-down transformer, $K < 1$

Energy Losses in Transformers

In actual transformers, small energy losses do occur due to the following reasons.

- (i) **Flux leakage** There is always some leakage of flux *i.e.*, not all of the flux due to primary passes through the secondary due to poor design of the core or the air gaps in the core. It can be reduced by winding the primary and secondary coils one over the other.
- (ii) **Resistance of the windings** The wire used for the windings has some resistance and so, energy is lost due to heat produced in the wire (I^2R). In high current, low voltage windings, these are minimised by using thick wire.
- (iii) **Eddy currents** The alternating magnetic flux induces eddy currents in the iron core and causes heating. The effect is reduced by having a laminated core.
- (iv) **Hysteresis** The magnetisation of the core is repeatedly reversed by an alternating magnetic field. The resulting expenditure of energy in the core appears as heat and is kept to a minimum by using a magnetic material which has a low hysteresis loss.
- (v) **Magnetostriction** It is the humming noise of a transformer.



Important Points

- Transformer does not operate on direct current. It operates only on alternating voltages at input as well as at output.
- Transformer does not amplify power as vacuum tube.
- Transformer, a device based on mutual induction converts magnetic energy into electrical energy.
- Efficiency, $\eta = \frac{\text{Output power}}{\text{Input power}}$

Generally efficiency ranges from 70% to 90%.

