

electromagnetic induction(solution)

Explanations

1.

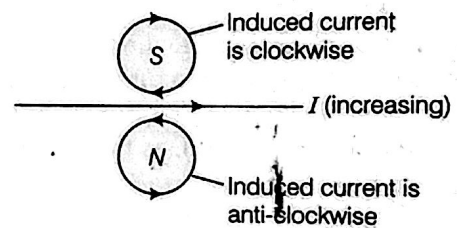

(1)

2. The flux created by straight current carrying wire is depicted in the figure.

As, induced emf (e) \propto rate of change of magnetic

flux (ϕ_B) and $\phi_B = \mathbf{B} \cdot \mathbf{A} = BA \cos \theta$

Here, $\mathbf{B} \perp \mathbf{A} \Rightarrow \phi_B = BA \cos 90^\circ = 0$

So, induced emf = 0

Hence, a change in current of wire will not create any emf in the loop.

(1)

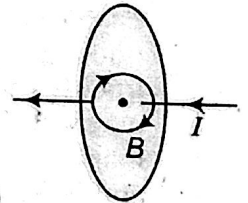

3. The direction of current in the coil is anti-clockwise. As North polarity of solenoid is moving towards the loop. So, to stop the motion of solenoid. Current will induced in the coil in anticlockwise direction (N-pole).

(1)

4. According to Lenz's law, the direction of induced current will oppose the cause of its production. So, the current in loop will induce in such a way that it will support the current flowing in the wire, i.e. in the same direction. So, the direction of current in the loop will be clockwise.

(1)

5. The glass bob will reach earlier on ground as acceleration due to gravity is independent of mass of the falling bodies. Glass being insulator, no induced current is developed in it due to the earth's magnetic field.

(1)

6. The wire is expanding to form a circle, which means that force is acting outwards on each part of the wire because of the magnetic field (acting in the downwards direction). The direction of the induced current should be such that it will produce magnetic field in upward direction (towards the reader). Hence, the force on the wire will be towards inward direction, i.e. induced current is flowing in anti-clockwise direction in the loop from *cbadc*. (1)

7. According to the Lenz's Law, the induced current will oppose the change.

The North pole is approaching the loop, so the induced current in the face of loop viewed from left side will flow in such a way that it will behave like North pole, so South pole developed in loop when viewed from right hand side of the loop. The flow of induced current is clockwise, hence A acquires positive polarity and B acquires negative polarity. (1)

8. Lenz's law states that the direction of induced emf or induced current in a circuit is such that it opposes the cause or the change that produces it. Yes, emf will be induced in the rod, as there is change in magnetic flux.

When a metallic rod held horizontally along East-West direction, is allowed to fall freely under gravity, i.e. fall from North to South, the intensity of magnetic lines of the earth's magnetic field changes through it, i.e. the magnetic flux changes and hence the induced emf in it. (1)

9. The magnitude of the emf induced in the circuit due to magnetic flux depends on the time rate of change of magnetic flux through the circuit.

$$|e| = d\phi / dt \quad (1)$$

10. Faraday, on the basis of his experiments, gave the following two laws:

First law Whenever magnetic flux linked with a circuit changes, an emf (and hence a current) is induced in it, which lasts as long as change in flux continue. (1/2)

Second law The emf induced in loop or closed circuit is directly proportional to the rate of change of magnetic flux linked with the loop

i.e.
$$e = -N \frac{d\phi}{dt}$$

where, N = Number of turns in the coil and negative sign indicates that the induced emf opposes the change in magnetic flux. (1/2)

11. Since, magnetic flux increases when the loop moves into uniform magnetic field. So, the induced current should oppose this increase. Thus, flow will be from *QPSRQ* i.e. anti-clockwise. (1)

12. Current in the wire is steadily decreasing, so the induced current in rings 1 and 2 will flow in such a way that it opposes the decrease of current. So, it will flow in same direction. Now, from the figure. It is clear that the direction of induced current in

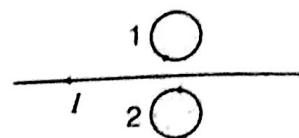

- (i) ring 1 is clockwise.
- (ii) ring 2 is anti-clockwise. (1)

13. From the figure, it is clear that North pole of the magnet is moving away from coil *PQ*, so the direction of current at end *Q* will flow in such a way that it will oppose the movement of North pole, so it has to act as South pole. Hence, the direction of current will be anti-clockwise.

Again, the South pole is approaching towards coil *CD*, so end *C* of the coil will act as South pole (to oppose the approaching of South pole). Hence, the direction of current will be clockwise. (1)

14. The induced current always opposes the change in magnetic flux. Loop *abc* is entering the magnetic field, so magnetic flux linked with loop tends to increase, so current induced in loop *abc* is anti-clockwise to produce magnetic field upward to oppose the increase in flux.

Loop *defg* is leaving the magnetic field; so flux linked with it tends to decrease, the induced current will be clockwise to produce magnetic field downward to oppose the decrease in magnetic flux.

15. Given, $v = 900 \text{ km/h}$

$$= 900 \times \frac{5}{18} = 250 \text{ m/s}$$

l = distance between the ends of the wings
= 20 m

Dip angle, $\delta = 30^\circ$

Horizontal component of earth's field
= $B_H = 5 \times 10^{-4} \text{ T}$

Potential difference induces due to cutting of vertical field lines. So, induced emf

$$= B_V \cdot l \cdot v = \frac{B_H}{\cos\delta} \cdot \sin\delta \cdot l \cdot v$$

$$\begin{aligned}
 &= B_H \cdot \tan\delta \cdot l \cdot v \\
 &\quad (\because B_H = B \cos\delta \text{ and } B_V = B \sin\delta) \\
 &= 5 \times 10^{-4} \times \tan 30^\circ \times 20 \times 250 \\
 &= \frac{2.5}{\sqrt{3}} \approx 1.45 \text{ V}
 \end{aligned}$$

16. According to figure, when wire AB is moved towards left at $A'B'$, then spring is stretched and provide a restoring force on wire, which starts moving towards right side, i.e. wire AB performs simple harmonic motion. In this case, magnetic flux linked with wire continuously changes, therefore an induced emf is produced across wire AB which is continuously decreases with time and finally becomes zero. (1)

17. According to figure shown in the question, induced current is in anti-clockwise, when seen from left hand side and its direction is in clockwise when seen from right hand side. Thus, direction of induced current is in clockwise sense. (1)

This implies that plate A of the capacitor is at the higher potential than plate B , i.e. B is a negative plate while A is a positive plate. (1)

18. To calculate the induced emf, first we have to find the change in flux. Here change in flux occurs due to change in area because of revolution of the rod. Then we can calculate the induced emf.

$$\text{Angular velocity of rod, } \omega = \frac{2\pi}{T}$$

where, T = time period

$$\therefore \text{Change in flux in one revolution} = \Delta\phi = B(\pi L^2)$$

According to Faraday's law of EMI, magnitude of induced emf

$$e = \frac{d\phi}{dT} = B\pi L^2/T$$

$$\Rightarrow e = B\pi L^2/(2\pi/\omega)$$

$$[\because T = 2\pi/\omega]$$

$$e = \frac{1}{2} B\omega L^2$$

This is the required expression. (2)

19. Large deflection means a high current for short time. So, to produce large deflection, induced current should be high and to produce high induced current, rate of change of flux should be high, i.e. more change in flux in less time.

(i) Large deflection in the galvanometer can be obtained when change in magnetic flux is fast. So, according to the diagram given in question,

(a) by moving the coil C_2 quickly, towards C_1 or by moving the coil C_2 quickly away from C_1 .

(b) by switching off and on the key. (1)

(ii) Alternative device in place of galvanometer can be LED or bulb. (1)

20. As N -pole of the magnet is moving away from the coil C_1 , therefore the coil will behave as South-pole and opposes the motion of the magnet. This implies the current in the coil is anti-clockwise. (1)

Also in coil C_2 , it behaves as S -pole in order to repel the coming magnet. This implies current in the coil is anti-clockwise. (1)

21. (i) The induced emf in both the loops will be same as areas of the loop and time periods are same as they are identical and rotated with same angular speed. (1)

(ii) The current induces in Cu coil is more than Al coil as Cu coil has lesser resistance and $I \propto \frac{1}{R}$

(for the same voltage). (1)

22. (i) According to the figure, the coil P should be moved quickly towards or away from the coil S . (1)

(ii) The laws involved here are Faraday's law of electromagnetic induction.

For statement Refer to Sol. 10 on page 182.

(First and second law) (1)

23. Induced current, is responsible for the lighting of the bulb, which depends on change of flux.

(i) Due to varying current in P , the flux linked with P change and hence Q changes, which in turn induces the emf in Q and bulb B lights, where P and Q are coils. (1)

(ii) When Q is moved left or it goes away from P , the lesser flux change takes place in Q . This leads to decrease in the value of rate of change of magnetic flux and hence, lesser emf and bulb B gets dimmer. (1)

24. (a) When a coil of area of cross-section A having N number of turns is rotating with angular velocity ω in uniform magnetic field B , then magnetic flux linked with coil

$$\phi = BA \cos\theta$$

$$\phi = BA \cos\omega t \quad [\because \theta = \omega t]$$

Induced emf (e) in the coil,

$$e = -N \frac{d\phi}{dt} = -N \frac{d}{dt} BA \cos\omega t$$

$$= NBA\omega \sin\omega t$$

[where, $e_0 = NBA\omega$]

$$e = e_0 \sin\omega t$$

(1½)

(b) Spokes = 100, length = 0.5 m
and $\omega = 120 \text{ rev/min}$
 $B_r = 4 \times 10^{-4} \text{ T}, \theta = 30^\circ$

$$E = \frac{1}{2} B_H l^2 \omega = \frac{1}{2} B_r \cos \theta l^2 \omega \quad [\because B_H = B_r \cos \theta]$$

$$= \frac{1}{2} \times 4 \times 10^{-4} \times \frac{\sqrt{3}}{2} \times (0.5)^2 \times 2\pi \times \frac{120}{60}$$

$$= 543 \times 10^{-4} \text{ V} \quad (1\frac{1}{2})$$

25. Given, $l = 20 \text{ cm} = 0.2 \text{ m}$,

$$B = 0.1 \text{ T}, v = 10 \text{ cms}^{-1} = 0.1 \text{ ms}^{-1}$$

(i) Magnetic flux through loop $\phi_B = B \cdot A = Blx$

$$\phi_{\text{max}} = 0.1 \times 0.2 \times 0.2 = 0.004 \text{ Wb} = 4 \times 10^{-3} \text{ Wb}$$

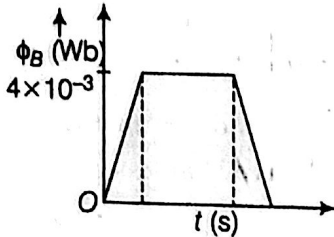

(ii) Induced emf, $\epsilon = \frac{-d\phi}{dt} = -Blv$

$$|\epsilon|_{\text{max}} = 0.1 \times 0.2 \times 0.1 = 0.002 \text{ V} = 2 \times 10^{-3} \text{ V}$$

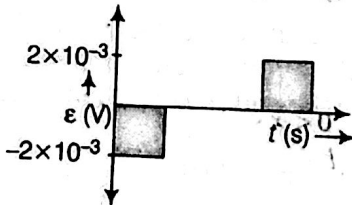
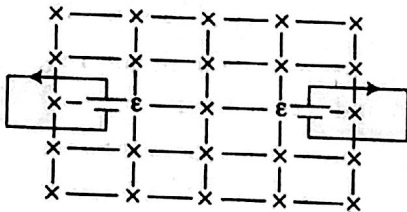

(iii) Induced current,

$$I = \frac{|\epsilon|}{R} = \frac{2 \times 10^{-3}}{0.1} = 2 \times 10^{-2} \text{ A}$$

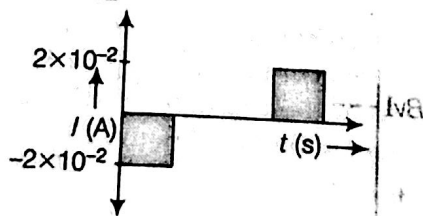

26. (i) Consider a straight conductor moving with uniform velocity v perpendicular magnetic field as shown in the figure. Let conductor shifts from ab to $a'b'$ in time dt , then change in magnetic flux
 $d\phi = B \times \text{change in area}$

$$= B \times (\text{area } a'b'ab)$$

$$= B \times (l \times v dt)$$

$$\therefore \frac{d\phi}{dt} = Bvl$$

$$\therefore \text{Induced emf } |e| = \frac{d\phi}{dt}$$

$$= Bvl$$

Thus, the emf induced across the ends of conductor due to its motion is called **motional emf**.

(ii) During motion, free e^- are shifted at one end due to magnetic force. So, due to polarisation of rod electric field is produced which applies electric force on free e^- in opposite direction. Thus, induced emf will be motional. (1/2)

At equilibrium of Lorentz force,

$$F_e + F_m = 0$$

$$\Rightarrow qE + q(v \times B) = 0$$

$$E = -v \times B = B \times v$$

$$|E| = |Bv \sin 90^\circ|$$

$$\frac{dV}{dr} = Bv$$

$$\therefore P_D = Bvl$$

27. (i) Force acting on the charged particle, moving with a velocity v , in a magnetic field B .

$$F = q(v \times B)$$

$$\text{As, } v \perp B, |\text{Force}| = qvB$$

Since $F \perp v$, it acts as a centripetal force and makes the particle move in a circular path, in the plane, perpendicular to the magnetic field.

$$\therefore qvB = \frac{mv^2}{r} \Rightarrow r = \frac{mv}{qB}$$

$$\text{Now, } \omega = \frac{v}{r} \Rightarrow \omega = \frac{qB}{m}$$

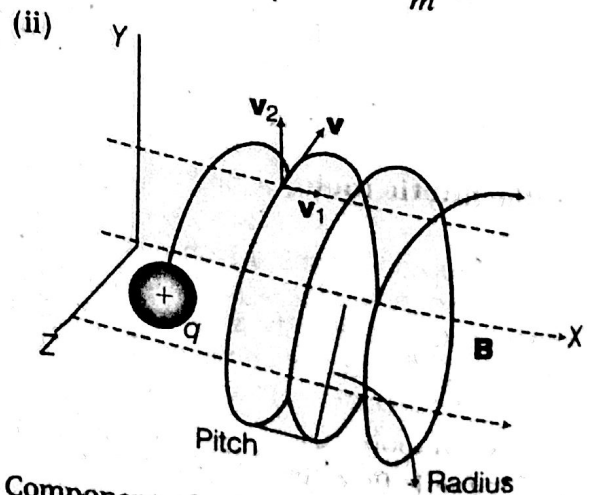

Component of velocity v parallel to magnetic field will make the particle move along the field.

Perpendicular component of velocity v , will cause the particle to move along a circular path in the plane perpendicular to the magnetic field. Hence, the particle will travel the helix path. (1½)

28. Magnitude of induced emf is directly proportional to the rate of area moving out of the field, for a constant magnetic field,

$$\epsilon = -\frac{d\phi}{dt} = -B \frac{dA}{dt} \quad (2)$$

For the rectangular coil, the rate of area moving out of the field remains same while it is not so for the circular coil. Therefore, the induced emf for the rectangular coil remains constant. (1)

29. (i) In the one revolution change of area, $dA = \pi l^2$

∴ Change of magnetic flux
 $d\phi = \mathbf{B} \cdot d\mathbf{A} = BdA \cos 0^\circ = B\pi l^2$

If period of revolution is T

(a) Induced emf (e) = $\frac{d\phi}{T} = \frac{B\pi l^2}{T} = B\pi l^2 v$

(b) Induced current in the rod,

$$I = \frac{e}{R} = \frac{\pi v B l^2}{R} \quad (2)$$

- (ii) Force acting on the rod, $F = I l B = \frac{\pi v B^2 l^3}{R}$

The external force required to rotate the rod opposes the Lorentz force acting on the rod/external force acts in the direction opposite to the Lorentz force. (2)

- (iii) Power required to rotate the rod.

$$P = Fv = \frac{\pi v B^2 l^3 v}{R} \quad (1)$$

30. In this question, first of all, we have to understand the given limits carefully in which the magnetic flux exists. Induced emf induces when change in the flux takes place. In both forward and backward journey, change in flux takes place.

For statement of Faraday's law of electromagnetic induction Refer to Sol. 10 on page 182. (1)

Case I Forward journey When PQ moves forward.

- (i) For $0 \leq x < b$

Magnetic field B exists in the region.

∴ Area of loop PQRS = lx

∴ Magnetic flux linked with loop PQRS,

$$\phi = BA = Blx$$

$$\phi = Blx \quad (\text{increasing}) \quad \dots(i) \quad (1)$$

- (ii) For, $b \leq x < 2b$

$$B = 0$$

Flux linked with loop PQRS is uniform and given by

$$\phi = Blb \quad \because x = b \text{ (constant)} \quad \dots(ii) \quad (1)$$

Case II Backward journey

From $2b$ to b

$$\phi = \text{constant} = Blb$$

From b to 0

$$\phi = Blx \quad (\text{decreasing})$$

Graphical representation

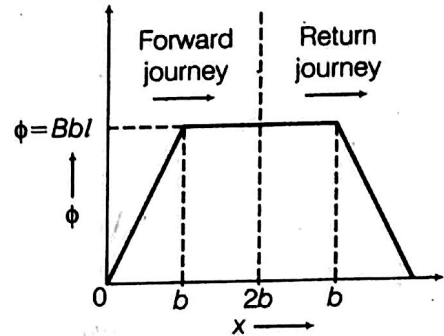

Induced emf

As, induced emf $\phi = Blx$

$$\Rightarrow \frac{d\phi}{dt} = Bl \frac{dx}{dt} = Bvl \quad \left[\because v = \frac{dx}{dt} \right]$$

Induced emf, $e = -\frac{d\phi}{dt} = -vBl$

For $2b \geq x \geq b$,

As, $\phi' = Blb \Rightarrow \frac{d\phi'}{dt} = 0 \Rightarrow e = 0$

Forward journey

For $0 \leq x < b \Rightarrow e = -vBl$

For $b \leq x \leq 2b \Rightarrow e = 0$

Backward journey

For $b > x \geq 0 \Rightarrow e = vBl$

For $2b \geq x \geq b, e = 0$

Variation of induced emf

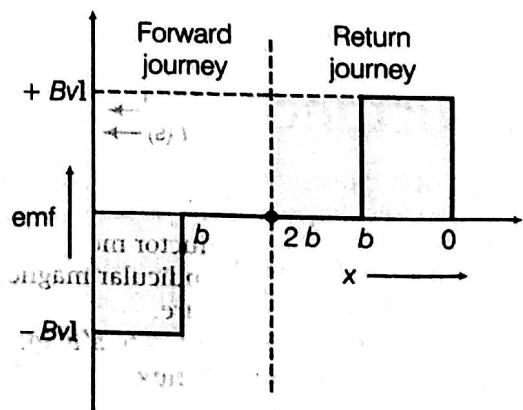

(1)

☑ Explanations

1. The phenomenon according to which an opposing emf is produced in a coil (i.e. primary coil) as a result of change in current or magnetic flux linked with a neighbouring coil (i.e. secondary coil) is called mutual induction.

SI unit of mutual inductance is Henry (H).

2. Self-inductance of a coil is equal to the total magnetic flux linked with the coil, when unit current passes through it.

Also, self-inductance of a coil, is equal to the emf induced in coil, when rate of change of current in coil is 1 A/s.

SI unit of self-inductance is 1 Henry (H)

$$1 \text{ H} = 1 \text{ V-s/A}$$

3. When a metallic piece is surrounded by a coil carrying high frequency alternating current, then eddy current is developed in the metallic piece and due to presence of resistance, metallic piece becomes hot.
4. The core of a transformer is laminated to prevent eddy current being produced in the core.
5. As, the copper plates oscillate in the magnetic field between the two poles of the magnet, there is a continuous change of magnetic flux linked with the plate. Due to this, eddy currents are set up in copper plate which try to oppose the motion of the plate (according to Lenz's law) and finally bring it to rest.
6. When the current begins to grow through the electromagnet, the magnetic flux through the disc begins to increase. This sets up eddy current in the disc in the same direction as that of the electromagnetic current.

Thus, if the upper surface of electromagnetic acquires *N*-polarity, the lower surface of the disc also acquires *N*-polarity. As, same magnetic poles repel each other, the light metallic disc is thrown up.

7. (i) As $\phi = MI$, with the increase in the distance between the coils the magnetic flux linked with the secondary coil decreases and hence, the mutual inductance of the two coils will decrease with the increase of separation between them.

(ii) Mutual inductance of two coils can be found out by $M = \mu_0 n_1 n_2 Al$, i.e. $M \propto n_1 n_2$, so, with the increase in number of turns mutual inductance increases. (1/2)

8. Self inductance is given by $L = \frac{\mu N^2 A}{l}$. L can be increased by increasing μ (permeability of medium), N (no. of turns), A (area of cross-section) and l (length). (1)

9. Self-inductance of the inductor, $L = \phi/I$.

The slope of ϕ vs I graph gives self-inductance of the coil.

Inductor A have got greater slope than inductor B, therefore self-inductance of A is greater than self-inductance of B. (1)

10. The energy of a capacitor is stored in the electric field between its plates. Similarly, an inductor has the capability of storing energy in its magnetic field.

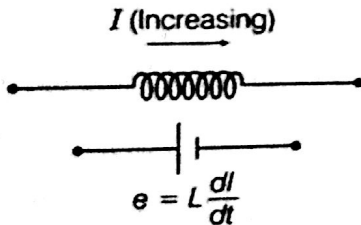

An increasing current in an inductor causes an emf between its terminals.

The work done per unit time is power,

$$P = \frac{dW}{dt} = -eI = -LI \frac{dI}{dt}$$

From $dW = -dU$ or $\frac{dW}{dt} = -\frac{dU}{dt}$, we have

$$\frac{dU}{dt} = LI \frac{dI}{dt} \quad \text{or} \quad dU = LI dI$$

The total energy U supplied while the current increases from zero to a final value I is

$$U = L \int_0^I IdI = \frac{1}{2} LI^2$$

$$W = U = \frac{1}{2} LI^2 \quad (1)$$

$$\text{The magnetic field, } B = \frac{\mu_0 NI}{l} \Rightarrow I = \frac{Bl}{\mu_0 N} \quad \dots(i)$$

$$\text{The self-inductance, } L = \frac{\mu_0 N^2 A}{l} \quad \dots(ii)$$

Putting values of L and I in Eq.,

$$U = \frac{1}{2} LI^2 \Rightarrow U_m = \frac{1}{2} \times \frac{\mu_0 N^2 A}{l} \times \frac{B^2 l^2}{\mu_0^2 N^2} = \frac{B^2 (Al)}{2\mu_0}$$

$$\Rightarrow \frac{U_m}{Al} = \frac{1}{2} \frac{B^2}{\mu_0}$$

where, $\frac{U_m}{Al}$ = energy density.

$$\therefore \bar{U}_m = \frac{1}{2} \frac{B^2}{\mu_0} \quad (1)$$

11. **Eddy current** Eddy currents are the currents induced in the bulk pieces of conductors when the amount of magnetic flux linked with the conductor changes. (1/2)

Eddy currents can be minimised by taking laminated core, consists of thin metallic sheet insulated from each other by varnish instead of a single solid mass. The plane of the sheets should be kept perpendicular to the direction of the currents. The insulation provides high resistance hence, eddy current gets minimised. (1)

Applications

- (i) Electromagnetic damping
- (ii) Induction furnace. (1/2)

12. The phenomenon of generation of induced emf in a long solenoid due to a change of current in another neighbourhood coaxial solenoid is known as mutual induction. (1)

For 2 long solenoids assuming perfect coupling, As, flux linked with second solenoid \propto current in first solenoid.

$$\therefore N_2 \phi_{B_1} \propto I_1$$

$$\frac{N_2 \phi_{B_1}}{I_1} = \text{a constant} = M$$

= mutual inductance of second coil w.r.t to first.

So, we have

$$M = M_{21} = \frac{N_2 \phi_{B_1}}{I_1} = \frac{n_2 l_2 (\mu_0 n_1 I_1) A_2}{l_1} = \mu_0 n_1 n_2 A_2 l_2$$

Here, $l_1 = l_2 = l$

Also, $A_2 = A_1 = A$ (they are wound over same core).

Hence, $M = \mu_0 n_1 n_2 Al$ (1)

13. Here, $\Delta I = -2 \text{ A}$

$$\Rightarrow \Delta t = 10 \times 10^{-3} \text{ s}$$

$$V = 200 \text{ V}$$

$$L = ?$$

$$\text{Induced emf, } e = -L \frac{\Delta I}{\Delta t} \quad (1)$$

$$200 = -L \left(\frac{-2}{10 \times 10^{-3}} \right)$$

$$200 = L \times 2 \times 10^2$$

$$\therefore \text{Self-induction, } L = 1 \text{ H} \quad (1)$$

14. Let a current I_2 flows through the outer circular coil of radius R . The magnetic field at the centre of the coil is

$$B_2 = \mu_0 I_2 / 2R$$

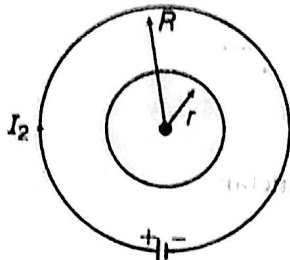

(1)

As $r \ll R$, hence field B_2 may be considered to be constant over the entire cross-sectional area of inner coil of radius r . Hence, magnetic flux linked with the smaller coil will be

$$\phi_1 = B_2 A_1 = \frac{\mu_0 I_2}{2R} \cdot \pi r^2$$

$$\text{As, by definition } \phi_1 = M_{12} I_2$$

Now mutual inductance,

$$M_{12} = \frac{\phi_1}{I_2} = \frac{\mu_0 \pi r^2}{2R}$$

$$\text{But suppose } M_{12} = M_{21} = M \therefore M = \frac{\mu_0 \pi r^2}{2R} \quad (1)$$

15. In case of two concentric coils when current flows through one coil, the emf is induced in the other coil.

Let current I_2 passes through the coil C_2 .

Magnetic field at centre due to current loop C_2

$$B_2 = \frac{\mu_0 N_2 I_2}{2r_2}$$

where, N_2 = number of turns in coil C_2 . (1/2)

\therefore Total magnetic flux linked with coil C_1 (1/2)

$$\phi_1 = N_1 B_2 A_1 \quad \mu_0 \mu_r H = M$$

$$\phi_1 = N_1 \left(\frac{\mu_0 N_2 I_2}{2r_2} \right) (\pi r_1^2)$$

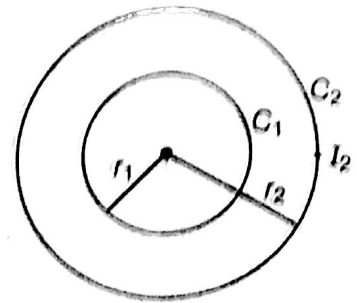

But

$$\phi = M I_2$$

$$\Rightarrow M I_2 = \frac{\mu_0 N_1 N_2 I_2 \pi r_1^2}{2r_2}$$

$$M = \frac{\mu_0 \pi N_1 N_2 r_1^2}{2r_2} \quad (1)$$

16.

Here, we will use the concept of work energy-theorem, i.e. here work against the emf induced will be stored in the form of magnetic energy.

The source of emf e establishes current in coil in opposition of induced emf (Lenz's rule) and hence does the work for the same. This work done by source stores in the form of magnetic energy in the coil.

Let, I current flows through the coil of self-inductance L at any instant t when rate of change of current in coil is dI/dt .

$$\therefore \text{Induced emf, } E = -L \frac{dI}{dt} \quad (1)$$

$$\text{Magnitude, } |E| = L dI/dt$$

\therefore Work done in establishing the current in small time interval dt is given by

$$dW = P dt = E I dt$$

$$= \left(L \frac{dI}{dt} \right) I dt$$

$$dW = L I dI$$

\therefore Total work done in increasing the current from zero to I .

$$\therefore W = \int_0^I L I dI = L \int_0^I I dI$$

$$= L \left[\frac{I^2}{2} \right]_0^I = \frac{1}{2} L (I^2 - 0^2)$$

$$W = \frac{1}{2} L I^2$$

This work is stored as the energy in the inductor. (1)

17. (a) **Principle** An AC generator is based on the phenomenon of electromagnetic induction which states that whenever magnetic flux linked with a conductor (or coil) changes, an emf is induced in the coil.

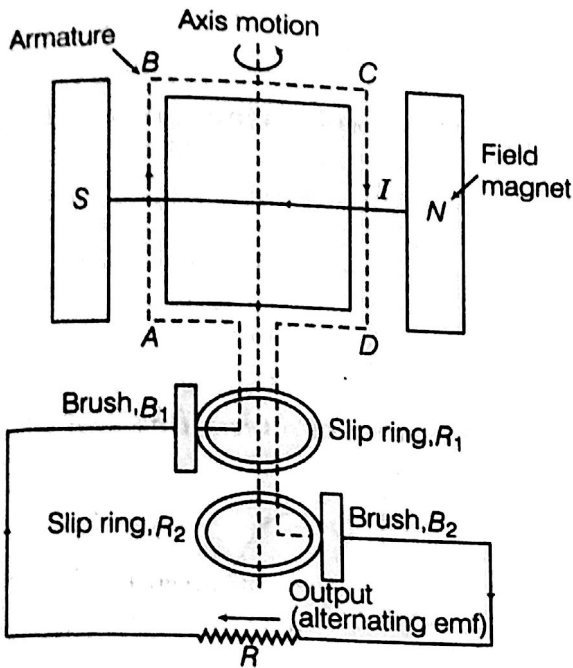

(1)

Working

As the armature of coil is rotated in the uniform magnetic field, angle θ between the field and normal to the coil changes continuously.

Therefore, magnetic flux linked with the coil changes and an emf is induced in the coil. According to Fleming's right hand rule, current induced in AB is from A to B and it is from C to D in CD. In the external circuit, current flows from B_2 to B_1 .

To calculate the magnitude of emf induced, suppose

A = area of each turn of the coil,
 N = number of turns in the coil,
 B = strength of magnetic field
and θ = angle which normal to the coil makes with B at any instant t .

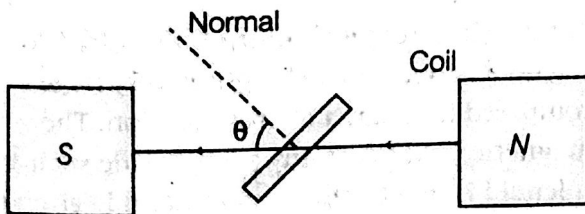

Magnetic flux linked with the coil in this position,

$$\phi = N (\mathbf{B} \cdot \mathbf{A})$$

or
$$\phi = NBA \cos \theta$$

$$\phi = NBA \cos \omega t$$

where, ω is angular velocity of the coil and symbols have usual meaning.

As we know, due to the rotation of the coil, an emf is being induced.
Thus, at this instant t , if e is the emf induced in the coil, then

$$e = - \frac{d\phi}{dt}$$

$$e = - \frac{d}{dt} (NAB \cos \omega t)$$

$$e = - NAB \frac{d}{dt} (\cos \omega t)$$

or
$$e = - NAB\omega (-\sin \omega t)$$

$$= NAB\omega \sin \omega t$$

where, $NBA\omega$ is the maximum value of the emf (also called peak value) which occurs when $\sin \omega t = \pm 1$.

If $NBA\omega = e_0$, then $e = e_0 \sin \omega t$ (2)

18. (i) Self-inductance of a coil is defined as the property due to which it opposes the change of current flowing through it by inducing a back emf in it.

Self-inductance L can be expressed as follows

$$\phi = Li$$

Here, ϕ is magnetic flux linked with the coil and i is the current flowing through it.

SI unit of self-inductance is Henry (H). (1½)

- (ii) Refer to Sol. 12 on page 191. (1½)

19. Refer to Sol. 12 on page 191. (3)

20. (i) Refer to Sol. 12 on page 191. (1½)

- (ii) Emf induced in the secondary coil is given by

$$e = \frac{-MdI}{dt}$$

$$\Rightarrow \frac{d\phi}{dt} = \frac{-MdI}{dt}$$

$$\Rightarrow d\phi = -MdI$$

or, $d\phi = -1.5 \times 20 = -30 \text{ Wb}$ (1½)

21. **Self-Inductance** When the current in a coil is changed, a back emf is induced in the same coil. This phenomenon is called self-inductance. If L is self-inductance of coil, then

$$N\phi \propto I \Rightarrow N\phi = LI$$

$$\Rightarrow L = \frac{N\phi}{I}$$

The SI unit of self-inductance is Henry (H). (1½)

- (ii) **Mutual Inductance** of solenoid coil system

$$M = \frac{\mu_0 N_1 N_2 A_2}{l}$$

Here, $N_1 = 15$, $N_2 = 1$, $l = 1 \text{ cm} = 10^{-2} \text{ m}$,

$$A = 2.0 \text{ cm}^2 = 20 \times 10^{-4} \text{ m}^2$$

$$\therefore M = \frac{4\pi \times 10^{-7} \times 15 \times 1 \times 2.0 \times 10^{-4}}{10^{-2}}$$

$$= 120\pi \times 10^{-9} \text{ H}$$

Induced emf in the loop

$$\epsilon_2 = M \frac{\Delta I_1}{\Delta t} \text{ (numerically)} = 120\pi \times 10^{-9} \frac{(4-2)}{0.1}$$

$$= 120 \times 3.14 \times 10^{-9} \times \frac{2}{0.1}$$

$$= 7.5 \times 10^{-6} \text{ V} = 7.5 \mu\text{V.}$$

(1½)

22. Principle AC generator works on the principle of electromagnetic induction. Whenever amount of magnetic flux linked with a coil changes, an emf is induced in the coil.

It lasts so long as the change in magnetic flux through the coil continues.

Labelled diagram of AC generator is shown below.

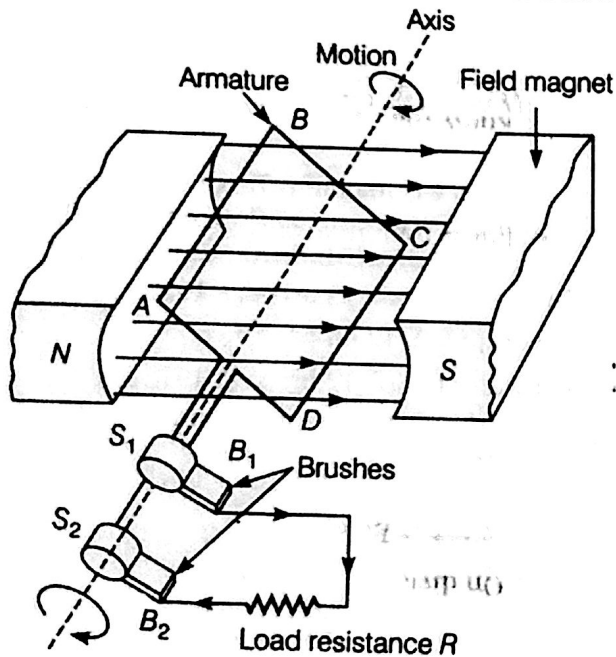

(1½)

Working When a closed armature coil rotates in a uniform magnetic field with its axis perpendicular to the magnetic field, the magnetic flux linked with the loop changes and emf induces in the coil. Let initially angle between area vector of coil and magnetic field B is 0° . Thereafter, AB comes downward and CD upward then by Fleming's right hand rule induced current flows from B to A .

During the next half revolution, when CD comes downward and AB upward then current flows from C to D . During the first half rotation, current flows through $BAS_2B_2RB_1DC$ and during next half rotation along $CD B_1RB_2S_2AB$. Hence,

$$e = -Nd\phi/dt = NBA\omega \sin \omega t, \text{ where } e_0 = NBA\omega$$

$$i = \frac{e_0}{R} \sin \omega t = i_0 \sin \omega t \quad \left[\text{Here, } \frac{e_0}{R} = i_0 \right]$$

(i) Variation of magnetic flux with time

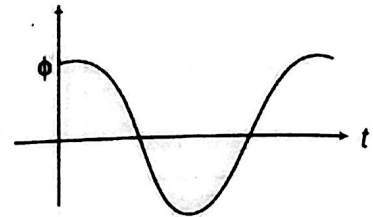

$$\phi = BNA \cos \omega t$$

(ii) Variation of alternating emf with time

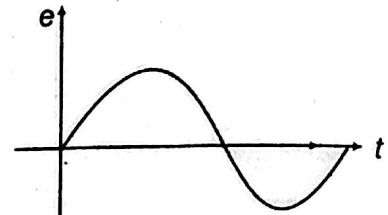

$$e = BNA\omega \sin \omega t$$

(1½)

23. Self-Inductance Self-inductance is the property of a coil by virtue of which, the coil opposes any change in the strength of current flowing through it by inducing an emf in itself.

The induced emf is also called **back emf**. When the current in a coil is switched on, the self-induction opposes the growth of the current and when the current is switched off, the self-induction opposes the decay of the current.

So, self-induction is also called the **inertia of electricity**.

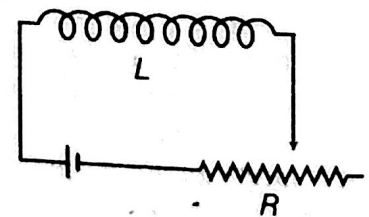

(1)

Magnetic Energy of Long Solenoid A long solenoid is one whose length is very large as compared to its area of cross-section. The magnetic field (B) at any point inside such a solenoid is practically constant and is given by

$$B = \frac{\mu_0 NI}{l} \quad \dots(i)$$

where, μ_0 = absolute magnetic permeability of free space, N = total number of turns in the solenoid and l = length of the solenoid.

\therefore Magnetic flux through each turn of the solenoid,

$$\phi = B \times \text{area of the each turn}$$

$$\phi = \left(\mu_0 \frac{N}{l} I \right) A$$

where, A = area of each turn of the solenoid.
 Total magnetic flux linked with the solenoid
 = Flux through each turn \times Total number of turns

$$N\phi = \mu_0 \frac{N}{l} IA \times N \quad \dots(ii)$$

If L is coefficient of self-inductance of the solenoid, then (e.g. soft iron)

$$\therefore N\phi = LI \quad \dots(iii)$$

From Eqs. (ii) and (iii), we get

$$LI = \mu_0 \frac{N}{l} IA \times N \text{ or } L = \frac{\mu_0 N^2 A}{l} \quad (1)$$

If core is of any other magnetic material μ is placed, then

$$\mu = \mu_0 \mu_r$$

$$\therefore L = \frac{\mu_0 \mu_r N^2 A}{l}$$

The magnitude of emf is given by

$$|e| \text{ or } e = L \frac{dI}{dt}$$

Multiplying (I) to both sides, we get

$$eI dt = LI dI \quad \dots(iv)$$

But $I = \frac{dq}{dt}$ or $I dt = dq$

Also, work done (dW) = voltage (e) \times charge (dq)

or $dW = e \times dq = eI dt$

Substituting these values in Eq. (iv), we get

$$dW = L I dI \quad \dots(v)$$

Total work done in increasing the current from zero to I_0 , we have

By integrating both sides of Eq. (v), we get

$$\int_0^W dW = \int_0^I L I dI$$

$$\Rightarrow W = \frac{1}{2} LI^2$$

The work done in increasing the current flowing through the inductor is stored as the potential energy (U) in the magnetic field of inductor

$$U = \frac{1}{2} LI^2 \quad (1)$$

24. Given, $L_1 = 16 \text{ mH}$

$L_2 = 12 \text{ mH}$

(i) Induced voltage is given by

Induced $V = L \frac{dI}{dt}$ (V = Induced voltage)

$\Rightarrow V \propto L$

$$\frac{V_1}{V_2} = \frac{L_1}{L_2} \quad (\text{as } \frac{dI}{dt} \text{ is same})$$

$$\Rightarrow \frac{V_1}{V_2} = \frac{16}{12} = \frac{4}{3} \quad \dots(i)$$

(ii) Power (P) = IV

Now, $\frac{I_1}{I_2} = \frac{V_2}{V_1}$ (as P is the same)

$$\Rightarrow \frac{I_1}{I_2} = \frac{3}{4} \quad \dots(ii)$$

(iii) Energy stored is given by coil 1 and coil 2

$$E_1 = \frac{1}{2} L_1 I_1^2 \quad \dots(iii)$$

$$E_2 = \frac{1}{2} L_2 I_2^2 \quad \dots(iv)$$

On dividing Eqs. (iii) and (iv), we get

$$\frac{E_1}{E_2} = \frac{L_1 I_1^2}{L_2 I_2^2} = \frac{16}{12} \times \frac{9}{16} \text{ [from Eq. (ii)]}$$

$$\frac{E_1}{E_2} = \frac{3}{4} \quad (1)$$

25. Energy stored in the magnetic field,

$$W = \frac{1}{2} LI^2 = \frac{1}{2} \frac{\mu_0 N^2 A}{l} \cdot \frac{B^2 l^2}{\mu_0^2 N^2} = \frac{B^2}{2\mu_0} (Al)$$

$$\left[\because L = \frac{\mu_0 N^2 A}{l}, B = \frac{\mu_0 NI}{l} \right] \quad (2)$$

We know that, energy density,

$$U_B = \frac{\text{Energy}}{\text{Volume}} = \frac{B^2}{2\mu_0} \quad [\text{As } V = Al] \quad (1)$$

26. (i) Whenever the current passing through a coil or circuit changes, the magnetic flux linked with a neighbouring coil or circuit will also change. Hence, an emf will be induced in the neighbouring coil or circuit. This phenomenon is called 'mutual induction'.

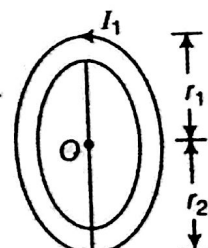

According to question, let the current in big coil of radius r_2 be I_1 , so, magnetic field at point O due to this coil will be $\mu_0 I_1 / 2r_2$.

Change in magnetic flux in the coil of radius r_1 is, $\phi = BA = \frac{\mu_0 I_1}{2r_2} \times \pi r_1^2$

$$\text{Mutual inductance, } M = \frac{\phi}{I_1} = \frac{\mu_0 I_1 \pi r_1^2}{2r_2 \times I_1} = \frac{\mu_0 \pi r_1^2}{2r_2}$$

This is the required expression. (3)

(ii) According to question, if the coil rotates with an angular velocity of ω and N turns through an angle θ in time t , thus $\theta = \omega t$

$$\therefore \phi = BA \cos \theta = BA \cos \omega t$$

As the coil rotates, the magnetic flux linked with it changes. An induced emf is set up in the coil which is given by

$$e = \frac{-d\phi}{dt} = \frac{-d}{dt} (BA \cos \omega t) = BA \omega \sin \omega t$$

For N number of turns, $e = NBA \omega \sin \omega t$

For maximum value of emf ωt must be equals to 90° .

So, maximum emf induced is $= NBA \omega$

$$\text{i.e. } e_0 = NBA 2\pi f \quad [\because \omega = 2\pi f] \quad (2)$$

27. (i) Refer to Sol. 1

(ii)

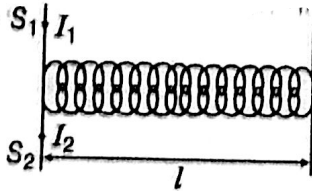

Let, n_1 = number of turns per unit length of S_1 ,
 n_2 = number of turns per unit length of S_2 ,
 I_1 = current passed through solenoid S_1 and
 ϕ_{21} = flux linked with S_2 due to current flowing through S_1

$$\phi_{21} \propto I_1 \Rightarrow \phi_{21} = M_{21} I_1$$

(where, M_{21} = coefficient of mutual induction of the two solenoids)

When current is passed through solenoid S_1 , an emf is induced in the solenoid S_2 .

Magnetic field produced inside solenoid S_1 on passing the current through it is given by

$$B_1 = \mu_0 n_1 I_1$$

Magnetic flux linked with each turn of solenoid S_2 will be equal to B_1 times the area of cross-section.

$$\Rightarrow \phi_{21} = B_1 A$$

Therefore, magnetic flux linked with the solenoid (S_2)

$$\begin{aligned} \phi_{21} &= B_1 A \times n_2 l \\ &= \mu_0 n_1 I_1 \times A \times n_2 l \\ \phi_{21} &= \mu_0 n_1 n_2 A l I_1 \end{aligned}$$

Here, we can write, $M_{21} = \mu_0 n_1 n_2 A l$... (i)

In the same manner, the mutual inductance between the two solenoids, when the current is passed through solenoid S_2 , then the emf is induced in the solenoid S_1 and it is given by

$$M_{12} = \mu_0 n_1 n_2 A l \quad \dots (ii)$$

$$M_{12} = M_{21} = M$$

On comparing Eqs. (i) and (ii), we get

$$M = \mu_0 n_1 n_2 A l$$

Again Eq. (i) can be written as,

$$M = \mu_0 \left(\frac{N_1}{l} \right) \left(\frac{N_2}{l} \right) \pi r_1^2 \times l$$

$$\Rightarrow M = \frac{\mu_0 N_1 N_2 A}{l}$$

(iii) Suppose that a current I is flowing through the coil C_2 at any instant. Flux linked with the coil C_1 is given by

$$\phi \propto I$$

$$\Rightarrow \phi = MI$$

where, M is the coefficient of mutual induction.

If e is the induced emf produced in the coil C_1 , then

$$e = \frac{d\phi}{dt} = - \frac{d}{dt} (MI) = - M \frac{dI}{dt}$$

28. (i)

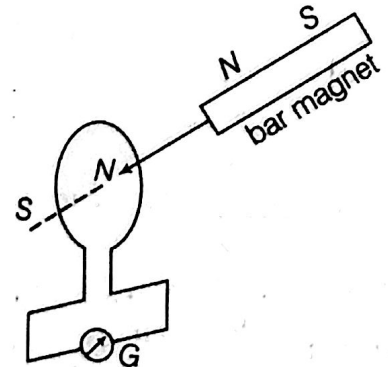
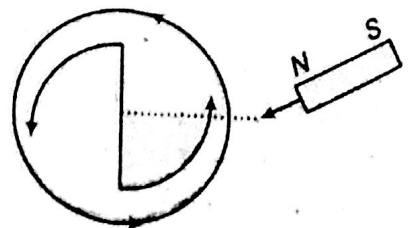

Figure shows a simple experiment to prove Lenz's law. When the North pole of the bar magnet is pushed towards the coil, the pointer in the galvanometer deflects indicating the presence of electric current in the coil.

The current induced in the coil is in anti-clockwise direction, so that it opposes the increase in flux through the coil due to the motion of the bar magnet.



When the North pole of the magnet is moved away from the coil, the magnetic flux through the

coil decreases and an induced current in the clockwise direction flows in the coil. This opposes the decrease in magnetic flux.

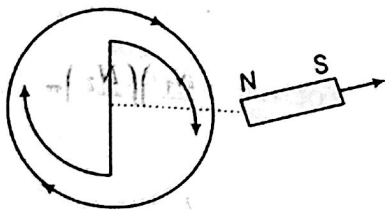

(ii) (a) Magnetic flux versus current

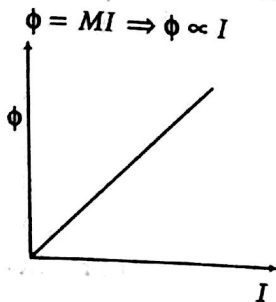

(b) Induced emf versus $dI/dt \Rightarrow e = -L(dI/dt)$
 dI/dt is positive and e is negative and constant.

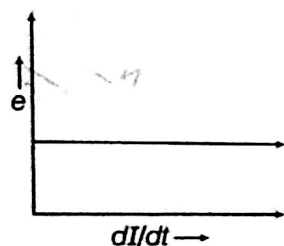

(c) Magnetic potential energy stored versus current

$$U = \frac{1}{2} L I^2 \Rightarrow U \propto I^2$$

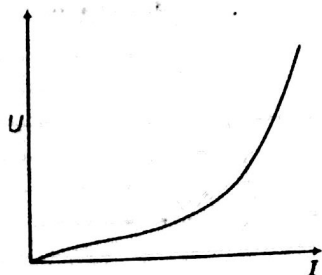

29. (i) For principle and working of AC generator, Refer to Sol. 22

(1 1/2)

(ii) The magnetic flux linked with the armature coil is changed by rotating it in the magnetic field between the poles of the magnet. (1/2)

(iii) Let at any instant total magnetic flux linked with the armature coil is given by ϕ .

$$\phi = NBA \cos \theta = NBA \cos \omega t$$

(where, $\theta = \omega t$ is the angle made by area vector of coil with magnetic field.)

$$\therefore \frac{d\phi}{dt} = \frac{d(NBA \cos \omega t)}{dt} \Rightarrow -\frac{d\phi}{dt} = NBA \omega \sin \omega t$$

By Faraday's law of EMI, $e = -\frac{d\phi}{dt}$

Induced emf in coil is given by,

$$e = NBA \omega \sin \omega t \Rightarrow e = e_0 \sin \omega t$$

where, $e_0 = NBA \omega =$ peak value of induced emf

(1)

Direction of induced emf can be determined using Fleming's right hand rule given below. If we stretch the thumb and the first two fingers of our right hand in mutually perpendicular directions and if the forefinger points in the direction of the magnetic field, thumb in the direction of motion of the conductor; then the central finger points in the direction of current induced in the conductor.

(1)

(iv)

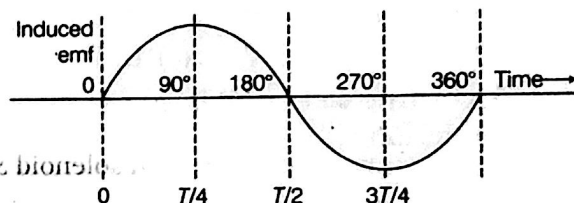

The mechanical energy spent in rotating the coil in magnetic field appears in the form of electrical energy.

(1)

30. (i) Refer to Sol. 22

(3)

(ii) As the earth's magnetic field lines are cut by the falling rod, the change in magnetic flux takes place. This change in flux induces an emf across the ends of the rod.

Since, the rod is falling under gravity.

$$v = gt$$

$$(\because u = 0)$$

$$\text{Induced emf, } \epsilon = Blv$$

$$\Rightarrow \epsilon = Blgt$$

$$\therefore \epsilon \propto t$$

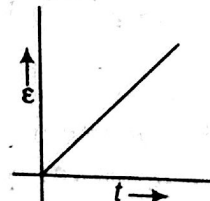

(2)

31. Refer to Sol. 22

29 (iii)

and Sol.

The source of energy is hydro electric power or thermal power etc.

(4)

(1)