

**PROJECTILE MOTION**

**PROJECTILE :**

Any object that is given an initial velocity obliquely, and that subsequently follow path determined by the net constant force.

**Examples of projectile motion :**

1. A cricket ball hit by the batsman for a six
2. A bullet fired from a gun
3. A packet dropped from a plane; but the motion of the aeroplane itself is not projectile motion because there are forces other than gravity on it due to the thrust of its engine.

**Projectile Motion :-**

1. The motion of projectile is known as projectile motion
2. It is the best example to understand motion in a plane. (Two dimensional motion)
3. If we project a particle obliquely from the surface of earth , as shown in the figure below, then it can be considered as two perpendicular 1D motion one along the horizontal and other along the vertical.

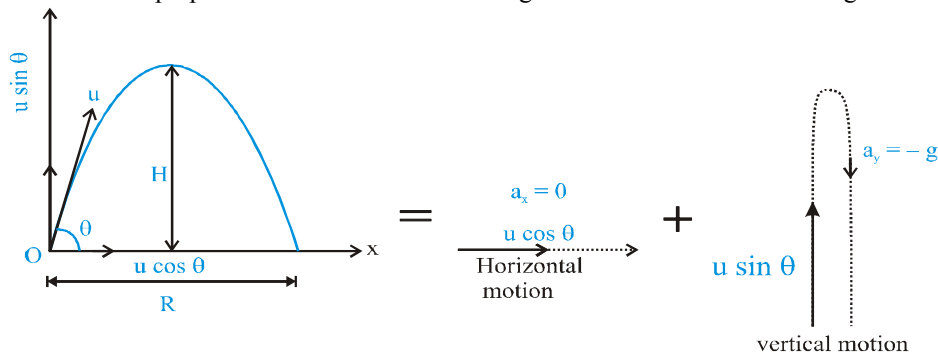

**Assumptions of projectile motion :**

1. We shall consider only trajectories that are of sufficiently short range so that the gravitational force can be considered constant in both magnitude and direction.
2. All effects of air resistance will be ignored.
3. Earth is assumed to be flat.

**Note : Galileo's Statement :-**

Two perpendicular direction of motion are independent from each other. In other words any vector quantity directed along a direction remains unaffected by a vector perpendicular to it.

**Projectile thrown at an angle with Horizontal :**

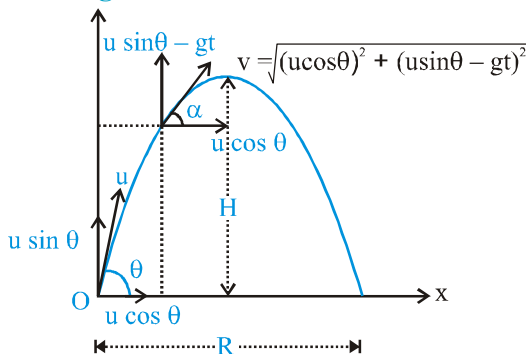

## PHYSICS FOR JEE MAINS & ADVANCED

1. Consider a projectile thrown with velocity  $u$  making an angle  $\theta$  with the horizontal.
2. Initial velocity  $u$  is resolved in components in a coordinate system in which horizontal direction is taken as x-axis, vertical direction as y-axis and point of projection as origin.

$$u_x = u \cos \theta \qquad u_y = u \sin \theta$$

3. Again this projectile motion can be considered as the combination of horizontal and vertical motion. Therefore,

- Horizontal direction**
- (a) Initial velocity  $u_x = u \cos \theta$
  - (b) Acceleration  $a_x = 0$
  - (c) Velocity after time  $t$ ,  $v_x = u \cos \theta$

- Vertical direction**
- Initial velocity  $u_y = u \sin \theta$   
 Acceleration  $a_y = g$   
 Velocity after time  $t$ ,  $v_y = u \sin \theta - gt$

### Time of flight :

The displacement along vertical direction is zero for the complete flight.  
 Hence, along vertical direction net displacement = 0

$$\Rightarrow (u \sin \theta)T - \frac{1}{2}gT^2 = 0 \qquad \Rightarrow \qquad T = \frac{2u \sin \theta}{g}$$

### Horizontal range :

$$R = u_x T \Rightarrow R = u \cos \theta \cdot \frac{2u \sin \theta}{g} \qquad \Rightarrow \qquad R = \frac{u^2 \sin 2\theta}{g}$$

### Maximum height :

At the highest point of its trajectory, particle moves horizontally, and hence vertical component of velocity is zero.  
 Using 3<sup>rd</sup> equation of motion i.e.

$$v^2 = u^2 + 2as$$

we have for vertical direction

$$0 = u^2 \sin^2 \theta - 2gH \qquad \Rightarrow \qquad H = \frac{u^2 \sin^2 \theta}{2g}$$

### Resultant velocity :

$$\vec{v} = v_x \hat{i} + v_y \hat{j} = u \cos \theta \hat{i} + (u \sin \theta - gt) \hat{j}$$

Where,  $|\vec{v}| = \sqrt{u^2 \cos^2 \theta + (u \sin \theta - gt)^2}$  and  $\tan \alpha = v_y / v_x$

Also  $v \cos \alpha = u \cos \theta \Rightarrow v = \frac{u \cos \theta}{\cos \alpha}$

**Note :** Vertical component of velocity is positive when particle is moving up and vertical component of velocity is negative when particle is coming down if vertical upwards direction is taken as positive.

### General result :

1. For maximum range  $\theta = 45^\circ$

$$R_{\max} = \frac{u^2}{g} \Rightarrow H_{\max} = \frac{R_{\max}}{2}$$

2. We get the same range for two angle of projection  $\alpha$  and  $(90 - \alpha)$  but in both cases, maximum heights attained by the particles are different.

This is because,  $R = \frac{u^2 \sin 2\theta}{g}$ , and  $\sin 2(90 - \alpha) = \sin 180 - 2\alpha = \sin 2\alpha$

3. If  $R = H$

i.e.  $\frac{u^2 \sin 2\theta}{g} = \frac{u^2 \sin^2 \theta}{2g} \qquad \Rightarrow \qquad \tan \theta = 4$

4. Range can also be expressed as

$$R = \frac{u^2 \sin 2\theta}{g} = \frac{2u \sin \theta \cdot u \cos \theta}{g} = \frac{2u_x u_y}{g}$$

**Ex.** A body is projected with a speed of  $30 \text{ ms}^{-1}$  at an angle of  $30^\circ$  with the vertical. Find the maximum height, time of flight and the horizontal range of the motion. [Take  $g = 10 \text{ m/s}^2$ ]

**Sol.** Here  $u = 30 \text{ ms}^{-1}$ , Angle of projection,  $\theta = 90 - 30 = 60^\circ$

Maximum height,

$$H = \frac{u^2 \sin^2 \theta}{2g} = \frac{30^2 \sin^2 60^\circ}{2 \times 10} = \frac{900}{20} \times \frac{3}{4} = \frac{135}{4} \text{ m}$$

Time of flight,

$$T = \frac{2u \sin \theta}{g} = \frac{2 \times 30 \times \sin 60^\circ}{10} = 3\sqrt{3} \text{ sec.}$$

$$\text{Horizontal range} = R = \frac{u^2 \sin 2\theta}{g} = \frac{30 \times 30 \times 2 \sin 60^\circ}{10} = 45\sqrt{3} \text{ m}$$

**Ex.** A projectile is thrown with a speed of  $100 \text{ m/s}$  making an angle of  $60^\circ$  with the horizontal. Find the time after which its inclination with the horizontal is  $45^\circ$ ?

**Sol.**  $u_x = 100 \times \cos 60^\circ = 50$

$$u_y = 100 \times \sin 60^\circ = 50\sqrt{3}$$

$$v_y = u_y + a_y t = 50\sqrt{3} - gt \quad \text{and} \quad v_x = u_x = 50$$

When angle is  $45^\circ$

$$\tan 45^\circ = \frac{v_y}{v_x} \Rightarrow v_y = v_x$$

$$50\sqrt{3} - gt = 50 \Rightarrow 50(\sqrt{3} - 1) = gt \Rightarrow t = 5(\sqrt{3} - 1) \text{ s}$$

**Ex.** A large number of bullets are fired in all directions with the same speed  $v$ . What is the maximum area on the ground which these bullets will spread ?

**Sol.** Maximum distance up to which a bullet can be fired is its maximum range, therefore

$$R_{\max} = \frac{v^2}{g}$$

$$\text{Maximum area} = \pi (R_{\max})^2 = \frac{\pi v^4}{g^2}.$$

**Ex.** The velocity of projection of a projectile is given by :  $\vec{u} = 5\hat{i} + 10\hat{j}$ . Find

- (a) Time of flight
- (b) Maximum height,
- (c) Range

**Sol.** (a) Time of flight =  $\frac{2u \sin \theta}{g} = \frac{2u_y}{g} = \frac{2 \times 10}{10} = 2 \text{ s}$

(b) Maximum height =  $\frac{u^2 \sin^2 \theta}{2g} = \frac{u_y^2}{2g} = \frac{10 \times 10}{2 \times 10} = 5 \text{ m}$

(c) Range =  $\frac{2u \sin \theta \cdot u \cos \theta}{g} = \frac{2u_x u_y}{g} = \frac{2 \times 10 \times 5}{10} = 10 \text{ m}$

## PHYSICS FOR JEE MAINS & ADVANCED

**Ex. :** A particle is projected at an angle of  $30^\circ$  w.r.t. horizontal with speed 20 m/s:

- (i) Find the position vector of the particle after 1s.
- (ii) Find the angle between velocity vector and position vector at  $t = 1$ s.

**Sol.:** (i)  $x = u \cos \theta t$

$$= 20 \times \frac{\sqrt{3}}{2} \times t = 10\sqrt{3} \text{ m}$$

$$y = u \sin \theta t - \frac{1}{2} \times 10 \times t^2$$

$$= 20 \times \frac{1}{2} \times (1) - 5(1)^2 = 5 \text{ m}$$

Position vector,  $\vec{r} = 10\sqrt{3}\hat{i} + 5\hat{j}$ ,  $|\vec{r}| = \sqrt{(10\sqrt{3})^2 + 5^2}$

(ii)  $v_x = 10\sqrt{3}\hat{i}$

$$v_y = u_y + a_y t = 10 - gt = 0$$

$$\therefore \vec{v} = 10\sqrt{3}\hat{i}, |\vec{v}| = 10\sqrt{3}$$

$$\vec{v} \cdot \vec{r} = (10\sqrt{3}\hat{i}) \cdot (10\sqrt{3}\hat{i} + 5\hat{j}) = 300$$

$$\vec{v} \cdot \vec{r} = |\vec{v}| |\vec{r}| \cos \theta$$

$$\Rightarrow \cos \theta = \frac{\vec{v} \cdot \vec{r}}{|\vec{v}| |\vec{r}|} = \frac{300}{10\sqrt{3} \sqrt{325}}$$

$$\Rightarrow \theta = \cos^{-1} \left( 2\sqrt{\frac{3}{13}} \right)$$

### EQUATION OF TRAJECTORY

The path followed by a particle (here projectile) during its motion is called its Trajectory. Equation of trajectory is the relation between instantaneous coordinates (Here x and y coordinates) of the particle.

If we consider the horizontal direction,

$$x = u_x t$$

$$x = u \cos \theta t \quad \dots(1)$$

For vertical direction :

$$y = u_y t - \frac{1}{2} g t^2$$

$$= u \sin \theta t - \frac{1}{2} g t^2 \quad \dots(2)$$

Eliminating 't' from equation (1) & (2)

$$y = u \sin \theta \cdot \frac{x}{u \cos \theta} - \frac{1}{2} g \left( \frac{x}{u \cos \theta} \right)^2$$

$$\Rightarrow y = x \tan \theta - \frac{g x^2}{2 u^2 \cos^2 \theta}$$

This is an equation of parabola called as trajectory equation of projectile motion.

Other forms of trajectory equation :

$$(i) \quad y = x \tan \theta - \frac{gx^2(1 + \tan^2 \theta)}{2u^2} \qquad (ii) \quad y = x \tan \theta - \frac{gx^2}{2u^2 \cos^2 \theta}$$

$$\Rightarrow y = x \tan \theta \left[ 1 - \frac{gx}{2u^2 \cos^2 \theta \tan \theta} \right]$$

$$\Rightarrow y = x \tan \theta \left[ 1 - \frac{gx}{2u^2 \sin \theta \cos \theta} \right]$$

$$\Rightarrow y = x \tan \theta \left[ 1 - \frac{x}{R} \right]$$

**Ex. :** Find the value of  $\theta$  in the diagram given below so that the projectile can hit the target.

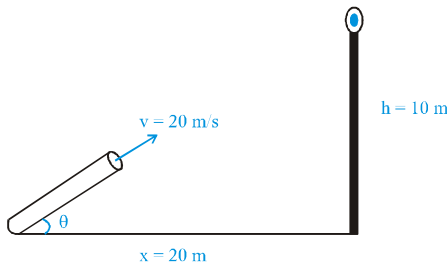

**Sol. :**  $y = x \tan \theta - \frac{gx^2(1 + \tan^2 \theta)}{2u^2}$

$$\Rightarrow 10 = 20 \tan \theta - \frac{5 \times (20)^2}{(20)^2} (1 + \tan^2 \theta)$$

$$\Rightarrow 2 = 4 \tan \theta - (1 + \tan^2 \theta) \Rightarrow \tan^2 \theta - 4 \tan \theta + 3 = 0$$

$$\Rightarrow (\tan \theta - 3)(\tan \theta - 1) = 0 \qquad \Rightarrow \tan \theta = 3, 1 \qquad \Rightarrow \theta = 45^\circ, \tan^{-1}(3)$$

**Ex. :** A ball is thrown from ground level so as to just clear a wall 4 m high at a distance of 4 m and falls at a distance of 14 m from the wall. Find the magnitude and direction of initial velocity of the ball. figure is given below.

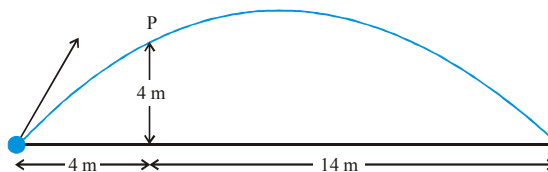

**Sol.** The ball passes through the point P (4, 4). Also range = 4 + 14 = 18 m.  
The trajectory of the ball is,

$$y = x \tan \theta \left( 1 - \frac{x}{R} \right)$$

**Now**  $x = 4\text{m}, y = 4\text{m}$  and  $R = 18\text{m}$

$$\therefore 4 = 4 \tan \theta \left[ 1 - \frac{4}{18} \right] = 4 \tan \theta \cdot \frac{7}{9}$$

**or**  $\tan \theta = \frac{9}{7} \Rightarrow \theta = \tan^{-1} \frac{9}{7}$

**and**  $R = \frac{2u^2 \sin \theta \cos \theta}{g}$

**or**  $18 = \frac{2}{9.8} \times u^2 \times \frac{9}{\sqrt{130}} \times \frac{7}{\sqrt{130}} \Rightarrow u = \sqrt{182}$

**PROJECTILE THROWN PARALLEL TO THE HORIZONTAL FROM SOME HEIGHT**

Consider a projectile thrown from point O at some height h from the ground with a velocity u. Now we shall study the characteristics of projectile motion by resolving the motion along horizontal and vertical directions.

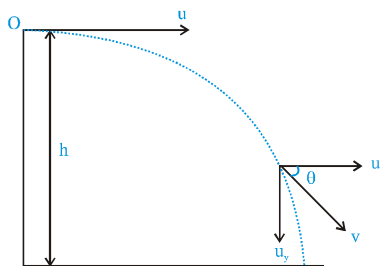

**Horizontal direction**

- (i) Initial velocity  $u_x = u$
- (ii) Acceleration  $a_x = 0$

**Vertical direction**

- Initial velocity  $u_y = 0$
- Acceleration  $a_y = g$  (downward)

**Time of flight :**

This is equal to the taken by the projectile to return to ground. From equation of motion

$$S = ut + \frac{1}{2}at^2, \text{ along vertical direction, we get}$$

$$-h = u_y t + \frac{1}{2}(-g)t^2$$

$$h = \frac{1}{2}gt^2 \Rightarrow t = \sqrt{\frac{2h}{g}}$$

**Horizontal range :**

Distance covered by the projectile along the horizontal direction between the point of projection to the point on the ground.

$$R = u_x t$$

$$R = u \sqrt{\frac{2h}{g}}$$

**Velocity at a general point (x, y)**

$$v = \sqrt{u_x^2 + u_y^2}$$

Here horizontal velocity of the projectile after time t

$$v_x = u$$

velocity of projectile in vertical direction after time t

$$v_y = 0 + (-g)t = -gt = gt \text{ (downward)}$$

$$\therefore v = \sqrt{u^2 + g^2 t^2} \text{ and } \tan \theta = v_y / v_x$$

**Velocity with which the projectile hits the ground :**

$$V_x = u$$

$$V_y^2 = 0^2 - 2g(-h)$$

$$V_y = \sqrt{2gh}$$

$$V = \sqrt{V_x^2 + V_y^2} \Rightarrow V = \sqrt{u^2 + 2gh}$$

**TRAJECTORY EQUATION :**

The path traced by projectile is called the trajectory.

After time  $t$ ,

$$x = ut \quad \dots(1)$$

$$y = \frac{-1}{2}gt^2 \quad \dots(2)$$

From equation (1)

$$t = x/u$$

Put the value of  $t$  in equation (2)

$$y = \frac{-1}{2}g \cdot \frac{x^2}{u^2}$$

This is trajectory equation of the particle projected horizontally from some height.

**Example based on horizontal projection from some height :**

**Ex.** A projectile is fired horizontally with a speed of  $98 \text{ ms}^{-1}$  from the top of a hill  $490 \text{ m}$  high. Find (i) the time taken to reach the ground (ii) the distance of the target from the hill and (iii) the velocity with which the projectile hits the ground. (take  $g = 9.8 \text{ m/s}^2$ )

**Sol.**

- (i) The projectile is fired from the top  $O$  of a hill with speed  $u = 98 \text{ ms}^{-1}$  along the horizontal as shown as  $OX$ . It reaches the target  $P$  at vertical depth  $OA$ , in the coordinates system as shown,  $OA = y = 490 \text{ m}$

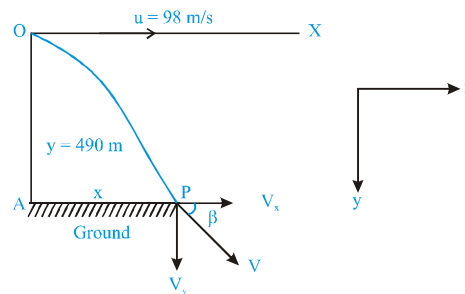

As,

$$y = \frac{1}{2}gt^2$$

$$490 = \frac{1}{2} \times 9.8t^2$$

or

$$t = \sqrt{100} = 10 \text{ s}$$

- (ii) Distance of the target from the hill is given by,  
 $Ap = x = \text{Horizontal velocity} \times \text{time} = 98 \times 10 = 980 \text{ m}$ .

- (iii) The horizontal and vertical components of velocity  $v$  of the projectile at point  $P$  are

$$v_x = u = 98 \text{ ms}^{-1}$$

$$v_y = u_y + gt = 0 + 9.8 \times 10 = 98 \text{ ms}^{-1}$$

$$V = \sqrt{v_x^2 + v_y^2} = \sqrt{98^2 + 98^2} = 98\sqrt{2} \text{ ms}^{-1}$$

Now if the resultant velocity  $v$  makes an angle  $\beta$  with the horizontal, then

$$\tan \beta = \frac{v_y}{v_x} = \frac{98}{98} = 1 \quad \therefore \beta = 45^\circ$$

## PHYSICS FOR JEE MAINS & ADVANCED

**Ex.** A motorcycle stunt rider rides off the edge of a cliff. Just at the edge his velocity is horizontal, with magnitude 9.0 m/s. Find the motorcycle's position, distance from the edge of the cliff and velocity after 0.5 s.

**Sol.** At  $t = 0.50$  s, the  $x$  and  $y$  coordinates are

$$x = v_0 t = (9.0 \text{ m/s})(0.50 \text{ s}) = 4.5 \text{ m}$$

$$y = -\frac{1}{2}gt^2 = -\frac{1}{2}(10 \text{ m/s}^2)(0.50 \text{ s})^2 = -\frac{5}{4} \text{ m}$$

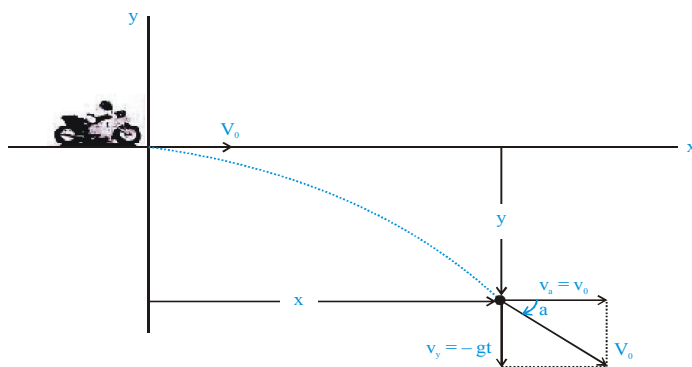

The negative value of  $y$  shows that this time the motorcycle is below its starting point. The motorcycle's distance from the origin at this time

$$r = \sqrt{x^2 + y^2} = \sqrt{\left(\frac{9}{2}\right)^2 + \left(\frac{5}{4}\right)^2} = \frac{\sqrt{349}}{4} \text{ m}$$

The components of velocity at this time are

$$v_x = v_0 = 9.0 \text{ m/s}$$

$$v_y = -gt = (-10 \text{ m/s}^2)(0.50 \text{ s}) = -5 \text{ m/s.}$$

The speed (magnitude of the velocity) at this time is

$$v = \sqrt{v_x^2 + v_y^2} = \sqrt{(9.0 \text{ m/s})^2 + (-5 \text{ m/s})^2} = \sqrt{106} \text{ m/s}$$

**Ex.** An object is thrown between two tall buildings. 180 m from each other. The object is thrown horizontally from a window 55 m above ground from one building through a window 10.9 m above ground in the other building. Find out the speed of projection. (use  $g = 9.8 \text{ m/s}^2$ )

**Sol. :**

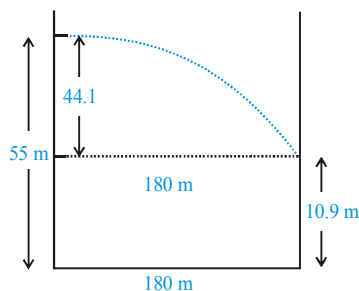

$$t = \sqrt{\frac{2h}{g}} = \sqrt{\frac{2 \times 44.1}{9.8}}$$

$$t = 3 \text{ sec.}$$

$$R = uT$$

$$\frac{180}{3} = u ; \quad u = 60 \text{ m/s}$$



**PROJECTION FROM A TOWER :**

**Case (i)** Horizontal projection  
 $u_x = u ; u_y = 0 ; a_y = -g$

This is same as previous section

**Case (ii)** Projection at an angle  $\theta$  above horizontal

$$u_x = u \cos \theta$$

$$u_y = u \sin \theta$$

$$a_y = -g$$

Equation of motion between A & B (in Y direction)

$$S_y = -h, u_y = u \sin \theta, a_y = -g, t = T$$

$$S_y = u_y t + \frac{1}{2} a_y t^2 \Rightarrow -h = u \sin \theta t - \frac{1}{2} g t^2$$

Solving this equation we will get time of flight, T.

And range,  $R = u_x T = u \cos \theta T$

Also,  $v_y^2 = u_y^2 + 2a_y S_y$   
 $= u^2 \sin^2 \theta + 2gh$

$$v_x = u \cos \theta$$

$$v_B = \sqrt{v_y^2 + v_x^2} \Rightarrow v_B = \sqrt{u^2 + 2gh}$$

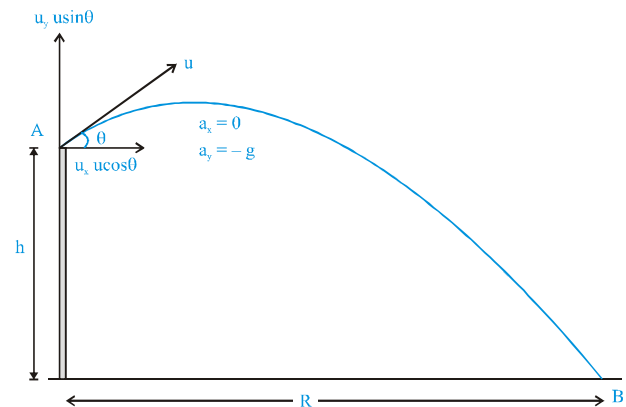

**Case (iii)** Projection at an angle  $\theta$  below horizontal

$$u_x = u \cos \theta$$

$$u_y = -u \sin \theta$$

$$a_y = -g$$

$$S_y = u_y t + \frac{1}{2} a_y t^2$$

$$S_y = -h, u_y = -u \sin \theta, t = T, a_y = -g$$

$$\Rightarrow -h = -u \sin \theta T - \frac{1}{2} g T^2 \Rightarrow h = u \sin \theta T + \frac{1}{2} g T^2$$

Solving the equation we will get time of flight, T

And range,  $R = u_x T = u \cos \theta T$

$$v_x = u \cos \theta$$

$$v_y = u_y^2 + 2a_y S_y = u^2 \sin^2 \theta + 2(-g)(-h)$$

$$v_y^2 = u^2 \sin^2 \theta + 2gh$$

$$v_B = \sqrt{v_x^2 + v_y^2} = \sqrt{u^2 + 2gh}$$

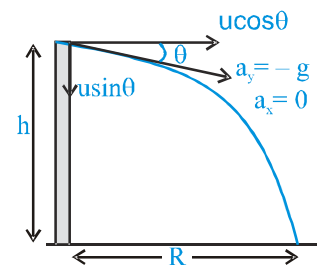

**Note :** Objects thrown from same height in different directions with same initial speed will strike the ground with the same final speed. But the time of flight will be different.

## PHYSICS FOR JEE MAINS & ADVANCED

**Ex. :** From the top of a 11 m high tower a stone is projected with speed 10 m/s, at an angle of  $37^\circ$  as shown in figure. Find

- (a) Speed after 2s
- (b) Time of flight
- (c) Horizontal range.
- (d) The maximum height attained by the particle.
- (e) Speed just before striking the ground.

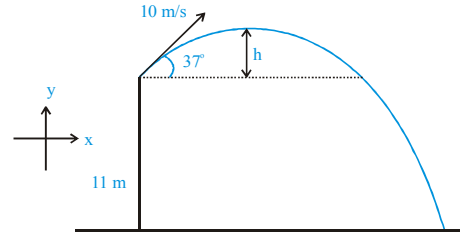

**Sol. :**

- (a) Initial velocity in horizontal direction =  $10 \cos 37^\circ = 8 \text{ m/s}$   
 Initial velocity in vertical direction =  $10 \sin 37^\circ = 6 \text{ m/s}$   
 Speed after 2 seconds

$$v = v_x \hat{i} + v_y \hat{j} = 8 \hat{i} + (u_y + a_y t) \hat{j} = 8 \hat{i} + (6 - 10 \times 2) \hat{j} = 8 \hat{i} - 14 \hat{j}$$

- (b)  $S_y = u_y t + \frac{1}{2} a_y t^2 \quad \Rightarrow \quad -11 = 6 \times t + \frac{1}{2} \times (-10) t^2$   
 $5t^2 - 6t = 11 \quad \Rightarrow \quad (t+1)(5t-11) = 0$   
 $\Rightarrow \quad t = \frac{11}{5} \text{ sec.}$

- (c) Range =  $8 \times \frac{11}{5} = \frac{88}{5} \text{ m}$

- (d) Maximum height above the level of projection,

$$h = \frac{u_y^2}{2g} = \frac{6^2}{2 \times 10} = 1.8 \text{ m}$$

$$\therefore \text{maximum height above ground} = 11 + 1.8 = 12.8 \text{ m}$$

- (e)  $v = \sqrt{u^2 + 2gh}$   
 $= \sqrt{100 + 2 \times 10 \times 11}$   
 $\Rightarrow v = 8\sqrt{5} \text{ m/s}$

**Ex. :** From the top of a 11 m high tower a stone is projected with speed 10 m/s, at an angle of  $37^\circ$  as shown in figure. Find

- (a) Time of flight.
- (b) Horizontal range.
- (c) Speed just before striking the ground.

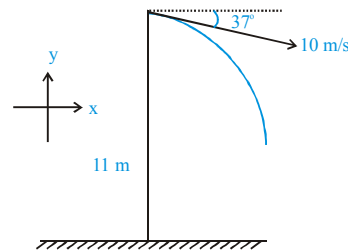

**Sol. :**  $u_x = 10 \cos 37^\circ = 8 \text{ m/s}$ ,  $u_y = -10 \sin 37^\circ = -6 \text{ m/s}$

- (a)  $S_y = u_y t + \frac{1}{2} a_y t^2$   
 $\Rightarrow \quad -11 = -6 \times t + \frac{1}{2} \times (-10) t^2$   
 $5t^2 + 6t - 11 = 0$

$$\Rightarrow \quad (t-1)(5t+11) = 0$$

$$\Rightarrow \quad t = 1 \text{ sec}$$

- (b) Range =  $8 \times 1 = 8 \text{ m}$

- (c)  $v = \sqrt{u^2 + 2gh} = \sqrt{100 + 2 \times 10 \times 11}$   
 $v = \sqrt{320} \text{ m/s} = 8\sqrt{5} \text{ m/s}$

**PROJECTION FROM A MOVING PLATFORM**

**Case (1) :** When a ball is thrown upward from a truck moving with uniform speed, then observer A standing in the truck, will see the ball moving in straight vertical line (upward & downward).

The observer B sitting on road, will see the ball moving in a parabolic path. The horizontal speed of the ball is equal to the speed of the truck.

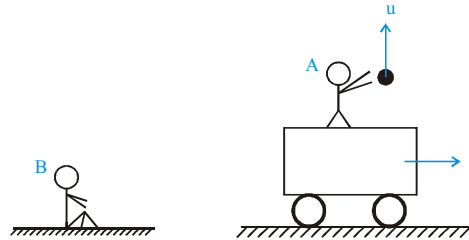

**Case (2) :** When a ball is thrown at some angle  $\theta$  in the direction of motion of the truck, horizontal & vertical component of ball's velocity w.r.t. observer A standing on the truck, is  $u \cos \theta$ , and  $u \sin \theta$  respectively.

Horizontal & vertical component of ball's velocity w.r.t. observer B sitting on the ground, is  $u_x = u \cos \theta + v$  and  $u_y = u \sin \theta$  respectively.

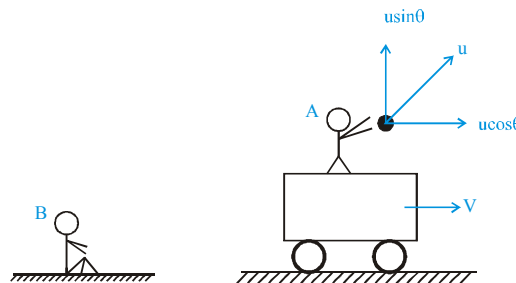

**Case (3) :** When a ball is thrown at some angle  $\theta$  in the opposite direction of motion of the truck, horizontal & vertical component of ball's velocity w.r.t. observer A standing on the truck, is  $u \cos \theta$ , and  $u \sin \theta$  respectively.

Horizontal & vertical component of ball's velocity w.r.t. observer B sitting on the ground, is  $u_x = u \cos \theta - v$  and  $u_y = u \sin \theta$  respectively.

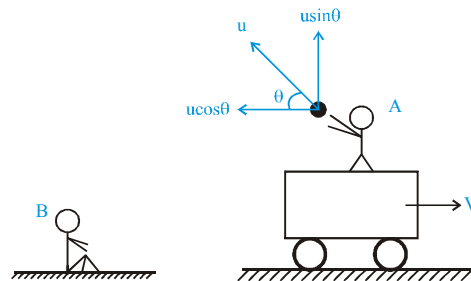

**Case (4) :** When a ball is thrown at some angle  $\theta$  from a platform moving with speed v upward, horizontal & vertical component of ball's velocity w.r.t. observer A standing on the moving platform, is  $u \cos \theta$  and  $u \sin \theta$  respectively.

Horizontal & vertical component of ball's velocity w.r.t. observer B sitting on the ground, is  $u_x = u \cos \theta$  and  $u_y = u \sin \theta + v$  respectively.

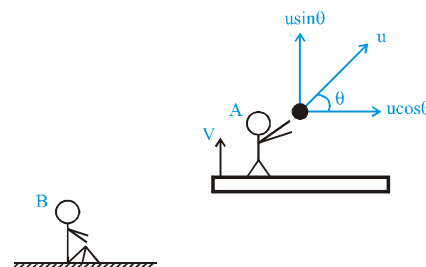

## PHYSICS FOR JEE MAINS & ADVANCED

**Case (5) :** When a ball is thrown at some angle ' $\theta$ ' from a platform moving with speed  $v$  downwards, horizontal & vertical component of ball's velocity w.r.t. observer A standing on the moving platform, is  $u \cos \theta$  and  $u \sin \theta$  respectively. Horizontal & vertical component of ball's velocity w.r.t. observer B sitting on the ground, is  $u_x = u \cos \theta$  and  $u_y = u \sin \theta - v$  respectively.

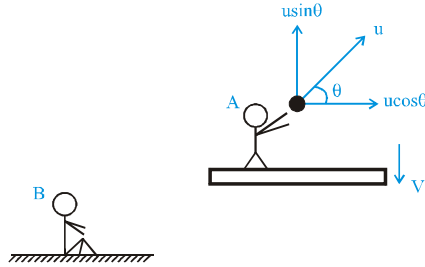

**Ex. :** A boy standing on a long railroad car throws a ball straight upwards. The car is moving on the horizontal road with an acceleration of  $1 \text{ m/s}^2$  and the projection speed in the vertical direction is  $9.8 \text{ m/s}$ . How far behind the boy will the ball fall on the car?

**Sol. :** Let the initial velocity of car be ' $u$ '  
time of flight,

$$t = \frac{2u_y}{g} = 2$$

where  $u_y$  = component of velocity in vertical direction

Distance travelled by car

$$x_c = u \times 2 + \frac{1}{2} \times 1 \times 2^2$$

$$= 2u + 2$$

distance travelled by ball

$$x_b = u \times 2$$

$$x_c - x_b = 2u + 2 - 2u = 2 \text{ m}$$

**Ex. :** A fighter plane moving with a speed of  $50\sqrt{2} \text{ m/s}$  upward at an angle of  $45^\circ$  with the vertical, releases a bomb. Find

(a) Time of flight

(b) Maximum height of the bomb above ground

**Sol. :** (a)  $y = u_y t + \frac{1}{2} a_y t^2$

$$-1000 = 50t - \frac{1}{2} \times 10 \times t^2$$

$$t^2 - 10t - 200 = 0$$

$$(t - 20)(t + 10) = 0$$

$$t = 20 \text{ sec}$$

(b)  $H = \frac{u_y^2}{2g} = \frac{50^2}{2g} = \frac{50 \times 50}{20} = 125 \text{ m}$

Hence maximum height above ground

$$H = 1000 + 125 = 1125 \text{ m}$$

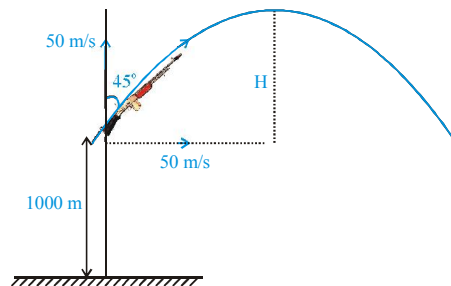

**PROJECTION ON AN INCLINED PLANE**

**Case (i) :**

Particle is projected up the incline  
 Here  $\alpha$  is angle of projection w.r.t. the inclined plane. x and y axis are taken along and perpendicular to the incline as shown in the diagram.

In this case :

$$a_x = -g \sin \beta$$

$$u_x = u \cos \alpha$$

$$a_y = -g \cos \beta$$

$$u_y = u \sin \alpha$$

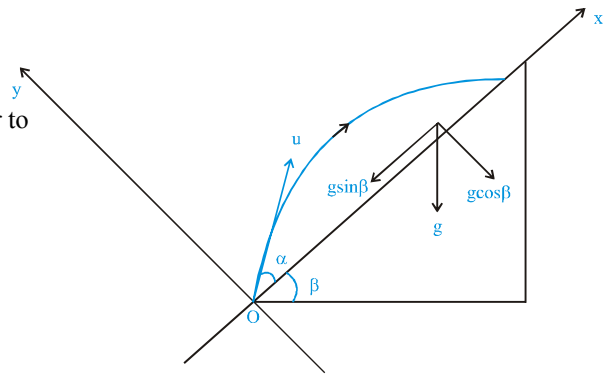

**Time of flight (T) :**

When the particle strikes the plane y becomes zero

$$y = u_y t + \frac{1}{2} a_y t^2$$

$$\Rightarrow 0 = u \sin \alpha T - \frac{1}{2} g \cos \beta T^2$$

$$\Rightarrow T = \frac{2u \sin \alpha}{g \cos \beta} = \frac{2u_{\perp}}{g_{\perp}}$$

where  $u_{\perp}$  and  $g_{\perp}$  are component of u and g perpendicular to the incline.

**Maximum height (H) :**

When half of the time elapsed y coordinate is equal to maximum distance from the inclined plane of the projectile

$$H = u \sin \alpha \left( \frac{u \sin \alpha}{g \cos \beta} \right) - \frac{1}{2} g \cos \beta \left( \frac{u \sin \alpha}{g \cos \beta} \right)^2 \Rightarrow H = \frac{u^2 \sin^2 \alpha}{2g \cos \beta} = \frac{u_{\perp}^2}{2g_{\perp}}$$

**Range along the inclined plane (R):**

When the particle strikes the inclined plane x coordinate is equal to range of the particle

$$x = u_x t + \frac{1}{2} a_x t^2$$

$$\Rightarrow R = u \cos \alpha \left( \frac{2u \sin \alpha}{g \cos \beta} \right) - \frac{1}{2} g \sin \beta \left( \frac{2u \sin \alpha}{g \cos \beta} \right)^2$$

$$\Rightarrow R = \frac{2u^2 \sin \alpha \cos(\alpha + \beta)}{g \cos^2 \beta}$$

**Case (ii) :**

Particle is projected down the incline

In this case :

$$a_x = g \sin \beta$$

$$u_x = u \cos \alpha$$

$$a_y = -g \cos \beta$$

$$u_y = u \sin \alpha$$

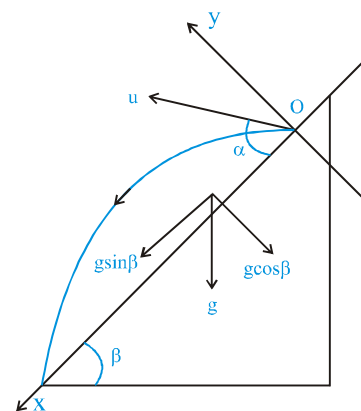

**Time of flight (T) :**

When the particle strikes the inclined plane y coordinate becomes zero

$$y = u_y t + \frac{1}{2} a_y t^2 \quad \Rightarrow \quad 0 = u \sin \alpha T - \frac{1}{2} g \cos \beta T^2 \quad \Rightarrow \quad T = \frac{2u \sin \alpha}{g \cos \beta} = \frac{2u_{\perp}}{g_{\perp}}$$

**Maximum height (H) :**

When half of the time is elapsed y coordinate is equal to maximum height of the projectile

$$H = u \sin \alpha \left( \frac{u \sin \alpha}{g \cos \beta} \right) - \frac{1}{2} g \sin \beta \left( \frac{u \cos \alpha}{g \cos \beta} \right)^2$$

$$\Rightarrow \quad H = \frac{u^2 \sin^2 \alpha}{2g \cos \beta} = \frac{u_{\perp}^2}{2g_{\perp}}$$

**Range along the inclined plane (R) :**

When the particle strikes the inclined plane x coordinate is equal to range of the particle

$$x = u_x t + \frac{1}{2} a_x t^2$$

$$\Rightarrow \quad R = u \cos \alpha \left( \frac{2u \sin \alpha}{g \cos \beta} \right) + \frac{1}{2} g \sin \beta \left( \frac{2u \sin \alpha}{g \cos \beta} \right)^2$$

$$\Rightarrow \quad R = \frac{2u^2 \sin \alpha \cos(\alpha - \beta)}{g \cos^2 \beta}$$

**Standard results for projectile motion on an inclined plane :**

	_____	_____
	_____	_____
	-- --	-- --
	_____	_____

**Note :** For a given speed, the direction which gives the maximum range of the projectile on an incline, bisects the angle between the incline and the vertical, for upward or downward projection.

**Ex. :** A bullet is fired from the bottom of the inclined plane at angle  $\theta = 37^\circ$  with the inclined plane. The angle of incline is  $30^\circ$  with the horizontal. Find (i) The position of the maximum height of the bullet from the inclined plane. (ii) Time of flight (iii) Horizontal range along the incline. (iv) For what value of  $\theta$  will range be maximum. (v) Maximum range.

**Sol. :** (i) Taking axis system as shown in figure

At highest point  $V_y = 0$

$$V_y^2 = U_y^2 + 2a_y y$$

$$0 = (30)^2 - 2g \cos 30^\circ y$$

$$y = 30\sqrt{3} \text{ (maximum height)} \quad \dots(1)$$

(ii) Again for x coordinate

$$V_y = U_y + a_y t$$

$$0 = 30 - g \cos 30^\circ \times t \Rightarrow t = 2\sqrt{3}$$

$$T = 2 \times 2\sqrt{3} \text{ sec Time of flight}$$

(iii)  $x = U_x t + \frac{1}{2} a_x t^2$

$$x = 40 \times 4\sqrt{3} - \frac{1}{2} g \sin 30^\circ \times (4\sqrt{3})^2$$

$$x = 40(4\sqrt{3} - 3) \text{ m} \quad \text{Range}$$

(iv)  $\frac{\pi}{4} - \frac{30^\circ}{2} = 45^\circ - 15^\circ = 30^\circ$

(v)  $\frac{u^2}{g(1 + \sin \beta)} = \frac{50 \times 50}{10 \left(1 + \frac{1}{2}\right)} = \frac{2500}{15} = \frac{500}{3} \text{ m}$

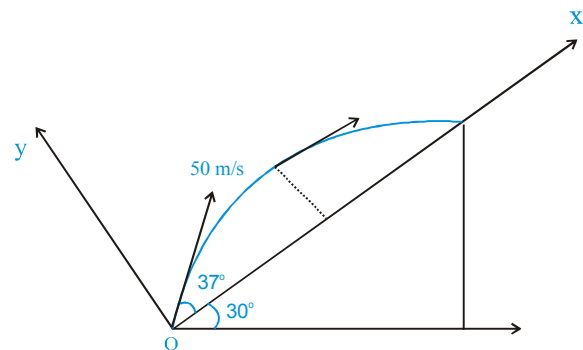

**Ex. :** A particle is projected horizontally with a speed  $u$  from the top of a plane inclined at an angle  $\theta$  with the horizontal. How far from the point of projection will the particle strike the plane?

**Sol.** Take X, Y-axes as shown in figure. Suppose that the particle strikes the plane at a point P with coordinates  $(x, y)$ . Consider the motion between A and P.

Suppose distance between A and P is S

Then position of P is

$$x = S \cos \theta$$

$$y = -S \sin \theta$$

Using equation of trajectory (For ordinary projectile motion)

$$y = x \tan \theta - \frac{gx^2}{2u^2 \cos^2 \theta}$$

here  $y = -S \sin \theta$

$$x = S \cos \theta$$

$\theta =$  angle of projection with horizontal  $= 0^\circ$

$$-S \sin \theta = S \cos \theta (0) - \frac{g(S \cos \theta)^2}{2u^2} \Rightarrow S = \frac{2u^2 \sin \theta}{g \cos^2 \theta}$$

Aliter:  $R = \frac{2u^2 \sin \alpha \cos(\alpha - \beta)}{g \cos^2 \beta}$

Here  $\alpha = \beta = \theta$

$$R = \frac{2u^2 \sin \theta}{g \cos^2 \theta}$$

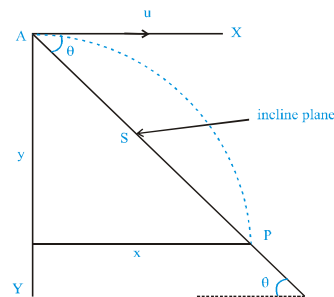

## PHYSICS FOR JEE MAINS & ADVANCED

**Ex. :** A projectile is thrown at an angle  $\theta$  with an inclined plane of inclination  $\beta$  as shown in figure. Find the relation between  $\beta$  and  $\theta$  if:

- Projectile strikes the inclined plane perpendicularly, to the inclined plane
- Projectile strikes the inclined plane horizontally, to the ground

**Sol.** (a) If projectile strikes perpendicularly.

$$v_x = 0 \text{ when projectile strikes}$$

$$v_x = u_x + a_x t$$

$$0 = u \cos \theta - g \sin \beta T$$

$$\Rightarrow T = \frac{u \cos \theta}{g \sin \beta}$$

We also know that  $T = \frac{2u \sin \theta}{g \cos \beta}$

$$\Rightarrow \frac{2u \sin \theta}{g \cos \beta} = \frac{2u \sin \theta}{g \cos \beta} \Rightarrow 2 \tan \theta = \cot \beta$$

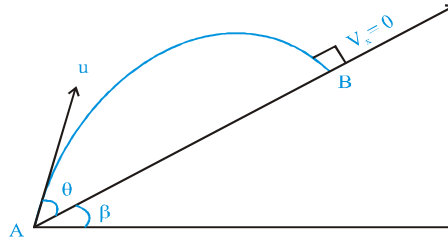

(b) If projectile strikes horizontally, then at the time of striking the projectile will be at the maximum height from the ground.

$$t_{AB} = \frac{1}{2} \text{ time of flight over horizontal plane}$$

$$= \frac{2u \sin(\theta + \beta)}{2 \times g}$$

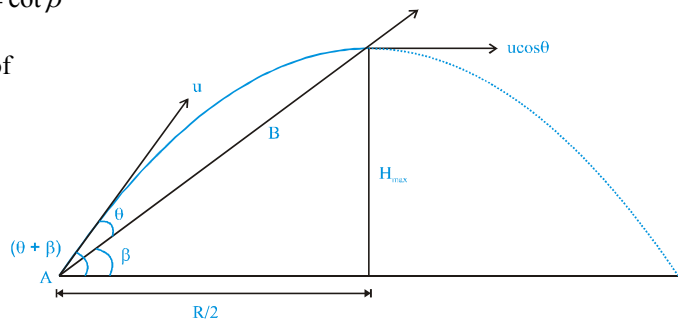

Also,  $t_{AB}$  = time of flight over incline

$$= \frac{2u \sin \theta}{g \cos \beta}$$

Equating for  $t_{AB}$ ,

$$\frac{2u \sin \theta}{g \cos \beta} = \frac{2u \sin(\theta + \beta)}{2g} \Rightarrow 2 \sin \theta = \sin(\theta + \beta) \cos \beta$$

### ELASTIC COLLISION OF A PROJECTILE WITH A WALL :

Suppose a projectile is projected with speed  $u$  at an angle  $\theta$  from point  $O$  on the ground. Range of the projectile is  $R$ . A vertical, smooth wall is present in the path of the projectile at a distance  $x$  from the point  $O$ . The collision of the projectile with the wall is elastic. Due to collision, direction of  $x$ -component of velocity is reserved but its magnitude remains the same and  $y$ -component of velocity remains unchanged. Therefore the remaining distance  $(R - x)$  is covered in the backward direction and the projectile lands at a distance of  $R - x$  from the wall. Also time of flight and maximum height depends only on  $y$  component of velocity, hence they do not change despite of collision with the vertical, smooth and elastic wall.

**Case I :** If  $x \geq \frac{R}{2}$



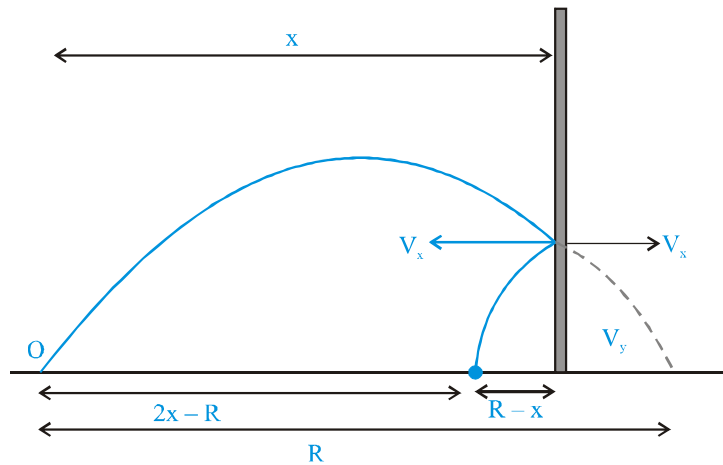

Here distance of landing place of projectile from its point of projection is  $2x - R$ .

**Case II :** If  $x < \frac{R}{2}$

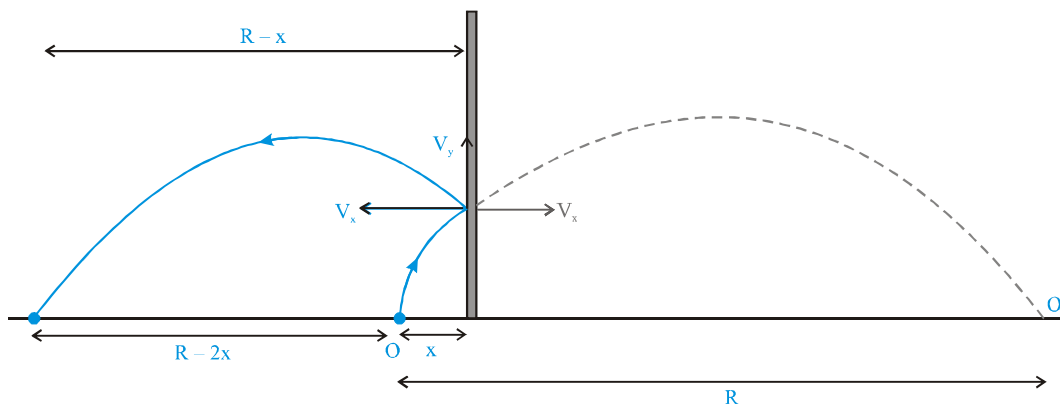

Here distance of landing place of projectile from its point of projection is  $R - 2x$ .

**Ex. :** A ball thrown from ground at an angle  $\theta = 37^\circ$  with speed  $u = 20$  m/s collides with A vertical wall 18.4 meter away from the point of projection. If the ball rebounds elastically to finally fall at some distance in front of the wall, find for this entire motion, (i) Maximum height (ii) Time of flight (iii) Distance from the wall where the ball will fall (iv) Distance from point of projection, where the ball will fall.

**Sol. :** (i) 
$$H = \frac{u^2 \sin^2 \theta}{2g} = \frac{(20)^2 \sin^2 37^\circ}{2 \times 10} = \frac{20 \times 20}{2 \times 10} \times \frac{3}{5} \times \frac{3}{5} = 7.2m$$

(ii) 
$$T = \frac{2u \sin \theta}{g} = \frac{2 \times 20 \times \sin 37^\circ}{10} = 2.4 \text{ sec}$$

(iii) 
$$R = \frac{u^2 \sin 2\theta}{g} = \frac{u^2}{g} \times 2 \sin \theta \cos \theta$$

$$\Rightarrow R = \frac{(20)^2}{10} \times 2 \sin 37^\circ = 38.4 \text{ m}$$

Distance from the wall where the ball falls =  $R - x$   
 $= 38.4 - 18.4 = 20 \text{ m}$

# PHYSICS FOR JEE MAINS & ADVANCED

(iv) Distance from the point of projection

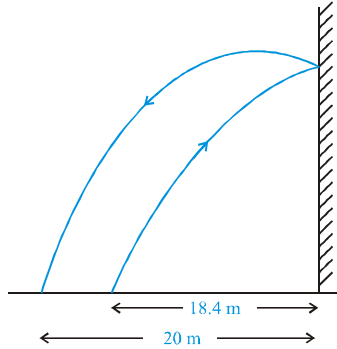

$$\begin{aligned}
 &= [R - 2x] \\
 &= [38.4 - 2 \times 18.4] \\
 &= 1.6 \text{ m}
 \end{aligned}$$

**Ex.** Two projectiles are thrown with different speeds and at different angles so as to cover the same maximum height. Find out the sum of the times taken by each to reach to highest point, if time of flight is T.

**Ans. :**

Total time taken by either of the projectile.

**Sol. :**  $H = H_2$  (given)

$$\frac{u_1^2 \sin^2 \theta_1}{2g} = \frac{u_2^2 \sin^2 \theta_2}{2g}$$

$$u_1^2 \sin^2 \theta_1 = u_2^2 \sin^2 \theta_2 \quad \dots\dots(1)$$

at maximum height final velocity = 0

$$v^2 = u_1^2 - 2gH$$

$$U_1^2 = 2gH_1 \quad \text{similarly} \quad U_2^2 = 2gH_2$$

$$U_1 = U_2$$

on putting in equation (1)

$$\Rightarrow u_1^2 \sin^2 \theta_1 = u_2^2 \sin^2 \theta_2 \quad \Rightarrow \quad \theta_1 = \theta_2$$

$$T_1 = \frac{2u_1 \sin \theta_1}{g} \Rightarrow T_2 = \frac{2u_2 \sin \theta_2}{g} \Rightarrow \quad \therefore T_1 = T_2$$

$$\text{Time taken to reach the maximum height by 1st projectile} = \frac{T_1}{2}$$

$$\text{Time taken to reach the maximum height by 2nd projectile} = \frac{T_2}{2}$$

$$\therefore \text{sum of time taken by each to reach highest point} = \frac{T_1}{2} + \frac{T_2}{2} = 2 \frac{T_1}{2} \left( \text{or } 2 \frac{T_2}{2} \right) = T_1 \text{ (or } T_2)$$

Total time taken either of the projectile

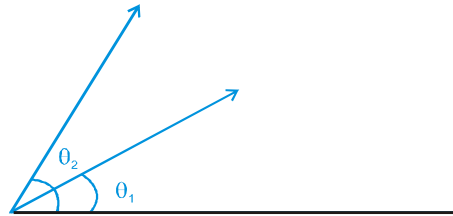

- Ex.** A particle is projected with speed 10 m/s at angle  $60^\circ$  with horizontal. Find :  
 (a) Time of flight (b) Range  
 (c) Maximum height (d) Velocity of particle after one second.  
 (e) Velocity when height of the particle is 1 m

**Ans. :**

(a)  $\sqrt{3}$  sec      (b)  $5\sqrt{3}$  m      (c)  $\frac{15}{4}$  m      (d)  $10\sqrt{2-\sqrt{3}}$  m/s      (e)  $\vec{v} = 5\hat{i} \pm \sqrt{55}\hat{j}$

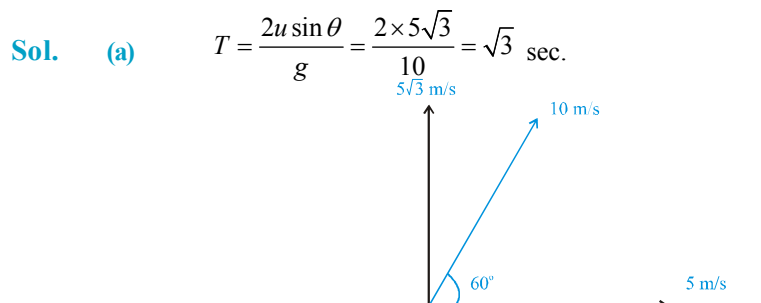

(b)  $\text{Range} = \frac{u^2 \sin 2\theta}{g} = \frac{10 \times 10 \times 2 \times \sin 60^\circ \cos 60^\circ}{10}$   
 $= 0.20 \times \frac{\sqrt{3}}{2} \times \frac{1}{2} = 5\sqrt{3} \text{ m}$

(c) maximum height  $H = \frac{u^2 \sin^2 \theta}{2g} = \frac{10 \times 10 \times 3}{2 \times 10 \times 4} = \frac{15}{4} \text{ m}$

(d) velocity at any time 't'  
 $\vec{v} = v_x \hat{i} + v_y \hat{j} \Rightarrow \vec{v}_x = \vec{u}_x \Rightarrow v_x = 5$   
 $\vec{v}_y = \vec{u}_y + \vec{a}_y t \Rightarrow v_y = 5\sqrt{3} - 10 \times 1$   
 $\vec{v} = 5\hat{i} + (5\sqrt{3} - 10)\hat{j} \text{ m/s} \Rightarrow v = 10(\sqrt{2-\sqrt{3}})$

(e)  $v^2 = u^2 + 2gh$   
 velocity at any height 'h' is  
 $\vec{v} = v_x \hat{i} + v_y \hat{j}$   
 $v_x = u_x = 5$   
 $v_y = u_y^2 - 2gh = (5\sqrt{3})^2 - 2 \times 10 \times 1$   
 $v_y = \sqrt{55} \Rightarrow \vec{v} = 5\hat{i} \pm \sqrt{55}\hat{j}$

- Ex.** A stone is thrown with a velocity  $v$  at angle  $\theta$  with horizontal. Find its speed when it makes an angle  $\beta$  with the horizontal.

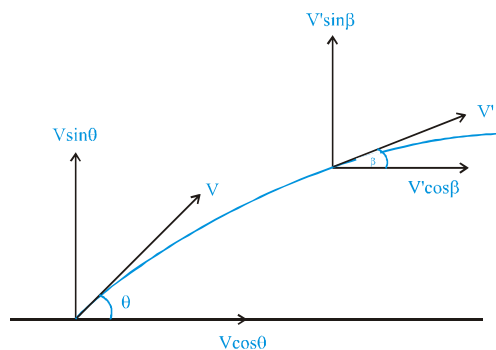

**Sol. :**  $v \cos \theta = v' \cos \beta \Rightarrow v' = \frac{v \cos \theta}{\cos \beta}$

## PHYSICS FOR JEE MAINS & ADVANCED

**Ex.** Two paper screens A and B are separated by a distance of 100 m. A bullet pierces A and then B. The hole in B is 10 cm below the hole in A. If the bullet is travelling horizontally at the time of hitting the paper and air.

**Ans. :** 700 m/s

**Sol. :** Equation of motion in x direction

$$100 = v \times t$$

$$t = \frac{100}{v} \quad \dots(1)$$

in y direction

$$0.1 = \frac{1}{2} \times 9.8 \times t^2 \quad \dots(2)$$

$$0.1 = \frac{1}{2} \times 9.8 \times \left(\frac{100}{v}\right)^2$$

From equation (1) & (2)

on solving we get

$$u = 700 \text{ m/s}$$

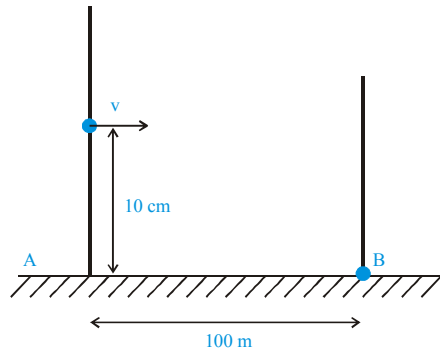

**Ex.** Two stones A and B are projected simultaneously from the top of a 100 m high tower. Stone B is projected horizontally with speed 10 m/s, and stone A is dropped from the tower. Find out the following ( $g = 10 \text{ m/s}^2$ )

- (a) Time of flight of the two stone                      (b) Distance between two stones after 3 sec.  
 (c) Angle of strike with ground                      (d) Horizontal range of particle B.

**Ans. :** (a)  $2\sqrt{5}$  sec.                      (b)  $x_B = 30 \text{ m}, y_B = 45 \text{ m}$                       (c)  $\tan^{-1} 2\sqrt{5}$                       (d)  $20\sqrt{5} \text{ m}$

**Sol. :** (a) To calculate time of flight (for both stone) apply equation of motion in y direction

$$100 = \frac{1}{2} g t^2$$

$$t = 2\sqrt{5} \text{ sec}$$

(b)  $X_B = 10 \times 3 = 30 \text{ m}$

$$Y_B = \frac{1}{2} \times g \times t^2$$

$$= \frac{1}{2} \times 10 \times 3 \times 3$$

$$Y_B = 45 \text{ m}$$

distance between two stones after 3sec.  $X_B = 30, Y_B = 45$

$$\text{So, distance} = \sqrt{(30)^2 + (45)^2}$$

(c) angle of striking with ground

$$v_y^2 = u_y^2 + 2gh = 0 + 2 \times 10 \times 100$$

$$v_y = 20\sqrt{5} \text{ m/s} \Rightarrow v_x = 10 \text{ m/s}$$

$$\therefore \vec{v} = v_x \hat{i} + v_y \hat{j} \Rightarrow \tan \theta = \frac{v_y}{v_x} \Rightarrow \theta = \tan^{-1} \left( \frac{20\sqrt{5}}{10} \right) = \tan^{-1} (2\sqrt{5})$$

(d) Horizontal range of particle 'B'

$$X_B = 10 \times (2\sqrt{5}) = 20\sqrt{5} \text{ m}$$

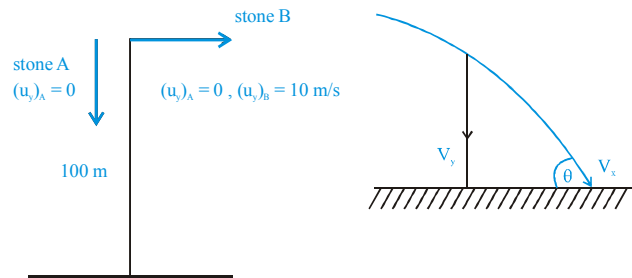

**Ex.** Ball bearings leaves the horizontal through with a velocity of magnitude 'u' and fall through the 70 mm diameter hole as shown. Calculate the permissible range of 'u' which will enable the balls to enter the hole. Take the dotted positions to represent the limiting conditions.

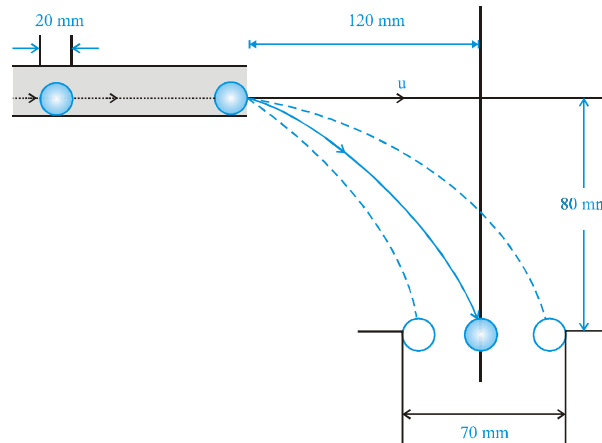

**Sol. :**  $t = \sqrt{\frac{2h}{g}} = \sqrt{\frac{2 \times 0.08}{9.8}} = 0.13 \text{ s}$

$$U_{\min} = \frac{(120 - 35 + 10) \times 10^{-3}}{0.13} = 0.73 \text{ m/s} \quad \text{and} \quad U_{\max} = \frac{(120 + 35 - 10) \times 10^{-3}}{0.13} = 1.115 \text{ m/s}$$

**Ex.** Particle A is released from a point P on a smooth inclined plane inclined at an angle  $\alpha$  with the horizontal. At the same instant another particle B is projected with initial velocity u making an angle  $\beta$  with the horizontal. Both the particles meet again on the inclined plane. Find the relation between  $\alpha$  and  $\beta$ .

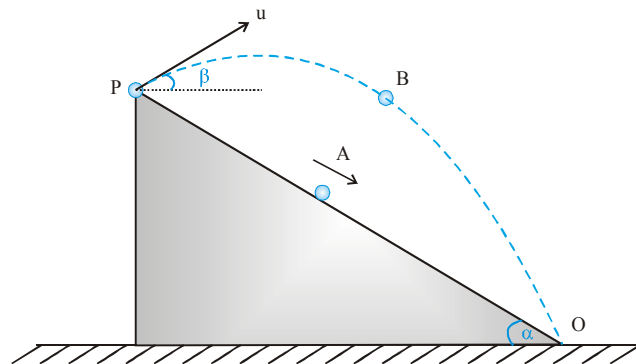

**Sol :**

Consider motion of B along the plane

Initial velocity =  $u \cos(\alpha + \beta)$

acceleration =  $g \sin \alpha$

$$\therefore OP = u \cos(\alpha + \beta)t + \frac{1}{2} g \sin(\alpha)t^2 \quad \dots(i)$$

For motion of particle A along the plane.

initial velocity = 0

acceleration =  $g \sin \alpha$

$$\therefore OP = \frac{1}{2} g \sin \alpha t^2 \quad \dots(ii)$$

From Equation. (i) and (ii)  $u \cos(\alpha + \beta) t = 0$

So, either  $t = 0$  or  $\alpha + \beta = \frac{\pi}{2}$

Thus, the condition for the particles to collide again is

$$\alpha + \beta = \frac{\pi}{2}$$